

**advanced FLOW engineering** Momentum Cold Air Intake System

**Instruction Manual** P/N: 56-70016D / 56-70016R

Make: Honda  
Make: Acura

Model: Accord  
Model: TLX

Year: 2013-2017  
Year: 2015-2020

Engine: V6-3.5L  
Engine: V6-3.5L



- Please read the entire instruction manual before proceeding.
- Ensure all components listed are present.
- If you are missing any of the components, call customer support.
- Ensure you have all necessary tools before proceeding.
- Do not attempt to work on your vehicle when the engine is hot.
- Retain factory parts for future use.

Label	Qty.	Description	Part Number
A1	1	Air Filter (Pro 5R)	24-91103
A2	1	Air Filter (Pro DRY S)	21-91103
B	1	Tube	05-5670016B1
C	1	Housing	05-5670016B2
D	1	Coupling, Silicone Bellow:(3.5"x2.75")ID x 4"L (Accord only)	05-01523
E	1	Coupling, Silicone Bellow:(3.5"x3.25")ID x 4"L (TLX only)	05-01522
F	1	Clamp, 048 (2-9/16" - 3-1/2")	03-50007
G	1	Clamp, 052 (2-13/16" - 3-3/4")	03-50008
H	2	Screw, Torx: M4	05-50491
I	1	Mount, Rubber	05-50534
J	1	Torx Bit: T20	03-50066

**Installation will require the following tools:**

T-20 Torx driver, 8mm nut driver, small flat-head screwdriver, Philips screwdriver, 10mm deep socket, extension and ratchet.

**Emissions Disclaimer:** This product is not currently CARB exempt and is not available for purchase in California or for use on any vehicle registered with the California Department of Motor Vehicles

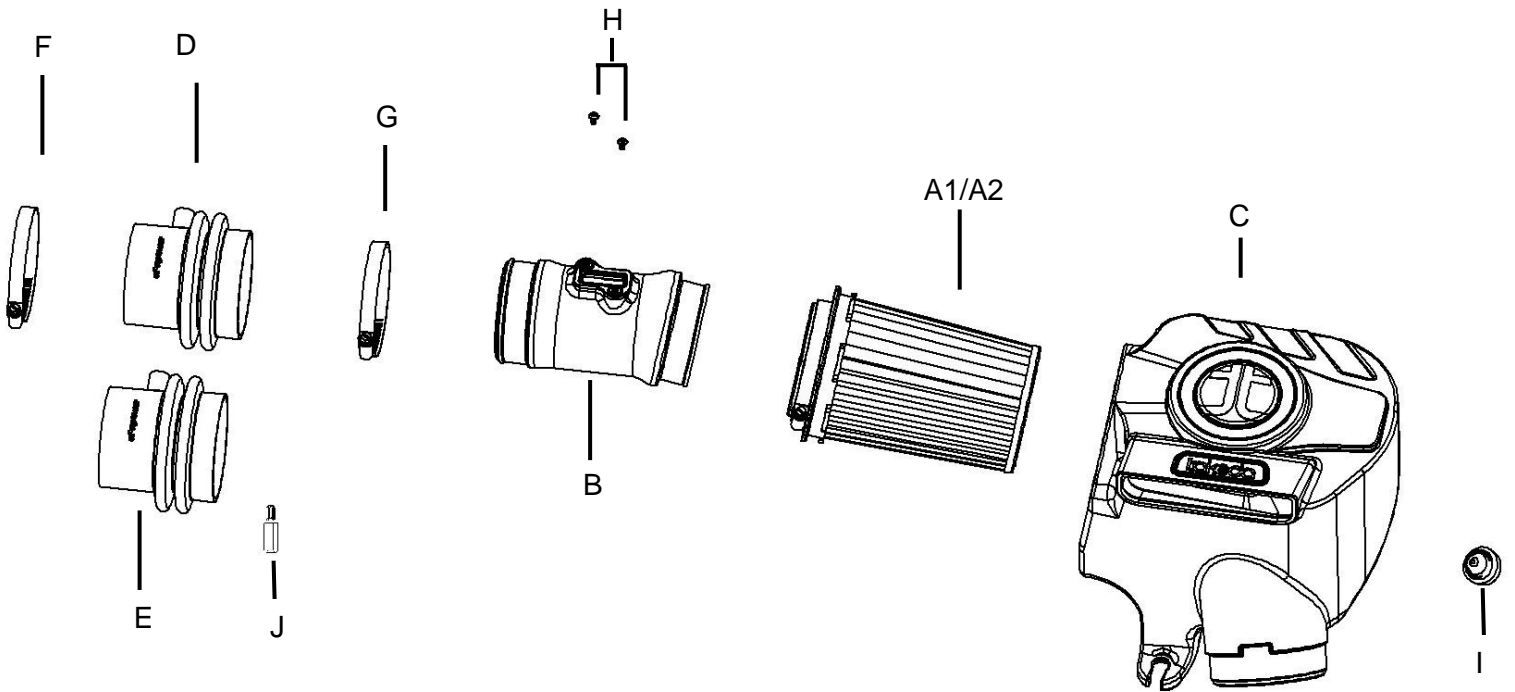

**Figure A****Refer to Figure A for Steps 1 (Acura TLX Showed on Pictures)**

Step 1: Remove the engine cover by popping it off its grommets ①.

**Figure B**

### **Refer to Figure B for Step 2-5**

Step 2: Disconnect the Mass Air Flow (MAF) ② harness from the sensor and unclip it from factory air box.

Step 3: Open the pinch clamp to disconnect the crank case fitting from the factory coupling ③.

Step 4: Remove the two 10mm screws securing the factory air box ④.

Step 5: Loosen the clamp on the factory coupling connecting to the throttle body ⑤.

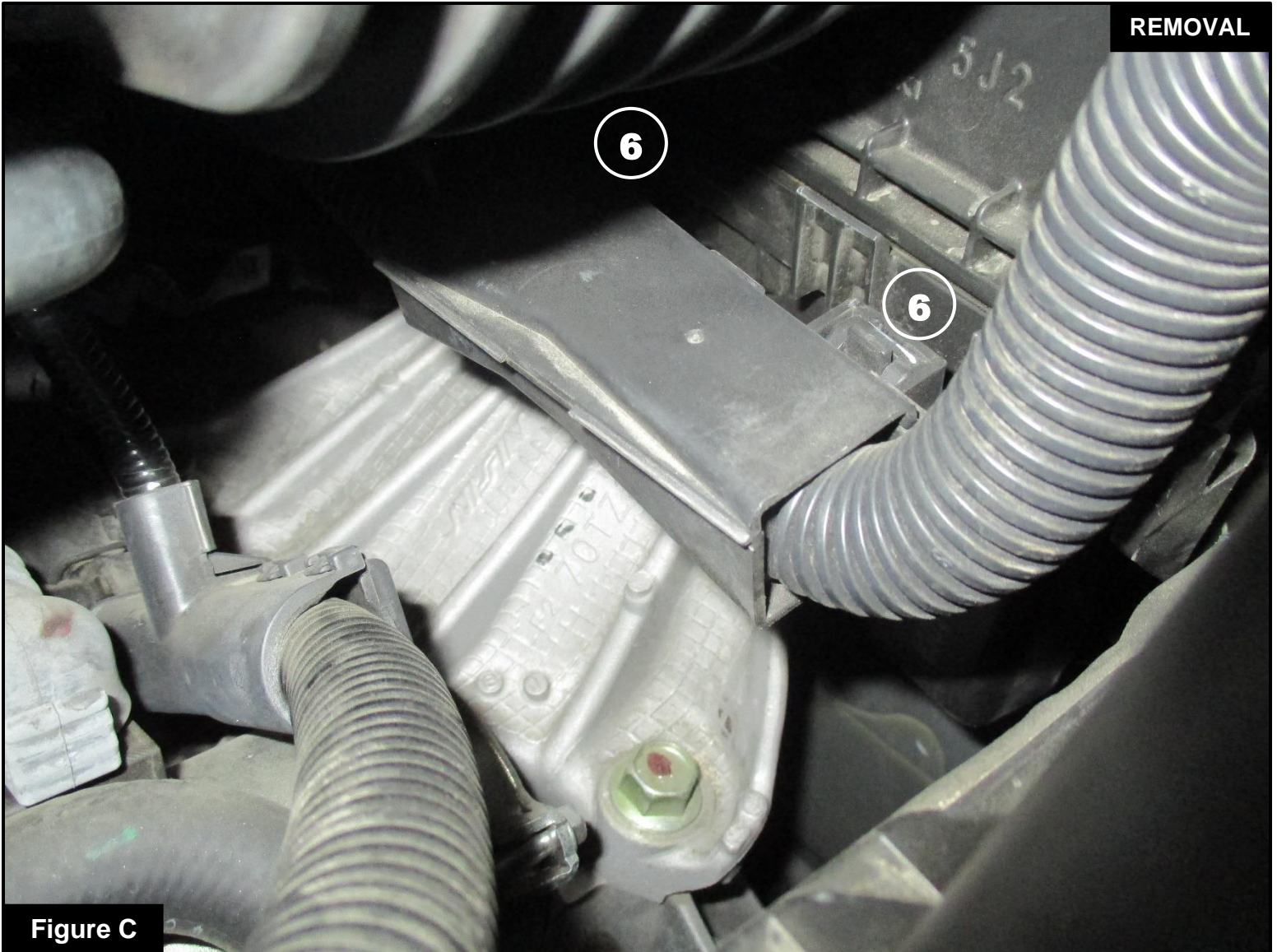
**Figure C****Refer to Figure C for Step 6-7**

Step 6: Disconnect the battery cable holder from the factory airbox by squeezing the release tabs ⑥.

Step 7: Remove factory intake system out of vehicle.

**Figure D****Refer to Figure D for Steps 8-9**

Step 8: Transfer the factory grommets with metal sleeves (7) from the factory air box onto the Takeda airbox.

Step 9: Install the supplied pop grommet (8) into the hole on the housing.

**Figure E****Refer to Figure E for Steps 10-11**

Step 10: Install the Takeda housing into the vehicle. Secure it with the factory screws removed at step 4.

Step 11: Slide the Takeda air filter into the housing, assure the filter tabs are locked on the housing. Place clamps on the filter but do not tighten at this time.



**Figure F****Refer to Figure F for Step 12-14**

Step 12: Slide the coupling onto the throttle body with clamps, make sure smaller side is on throttle body. Do not tighten clamps at this time.

**( For Honda Accord use coupling 05-01523, For Acura TLX use coupling 05-01522)**

Step 13: Transfer the factory pinch clamp from factory coupling to the Takeda coupling port.

Step 14: Insert the crank case fitting into the Takeda Coupling and secure with factory pinch clamp.

**Figure E****Refer to Figure E for Steps 15**

Step 15: Transfer the MAF sensor from the factory housing to the Takeda intake tube. Secure it with the M4 screws provided.

**Figure F****Refer to Figure F for Step 16-18**

Step 16: Slide the intake tube into the air filter then into the coupling. Align coupling, tube and air filter then tighten all clamps.

Step 17: Re-connect MAF sensor harness.

Step 18: Make sure all clamps and connections are secured.

**Figure F****Refer to Figure F for Step 19**

Step 19: Reinstall the engine cover. Your installation is now completed.

**NOTE: Check all bolts, clamps and connectors after 100-200 miles.**



Pro DRY S Air Filter



P/N: 24-91103

Pro 5R Air Filter



P/N: 24-91103

Pre-Filter



P/N: 28-10083

Blue Squeeze Restore Kit



P/N: 90-50501

Pro DRY S Restore Kit



P/N: 90-59999

Takeda Dynamic Air Scoop



P/N: 56-70016S

Honda Accord TBS



P/N: 46-37002

Acura TLX TBS



P/N: 46-37004