

advanced FLOW engineering Takeda Dynamic Air Scoop

Instruction Manual

P/N: 56-70005S/ 56-70005SR/ 56-70005SL/ 56-70005SE

Make: Hyundai
Make: Hyundai

Model: Elantra GT
Model: i30

Year: 2017-2020
Year: 2017-2020

Engine: L4-1.6L(t)
Engine: L4-1.6L(t)



- Please read the entire instruction manual before proceeding.
- Ensure all components listed are present.
- Ensure you have all necessary tools before proceeding.
- Do not attempt to work on your vehicle when the engine is hot.
- Retain factory parts for future use.

Label	Qty.	Description	Part Number
A1	1	Scoop (Black)	05-5670005B3
A2	1	Scoop (Red)	05-5670005R3
A3	1	Scoop (Blue)	05-5670005L3
A4	1	Scoop (Neon Green)	05-5670005E3
B	1	Magnet with Stud	03-50660

Installation will require the following tools:

8mm socket or nut driver, flat-blade screwdriver or plastic trim prybar, 10mm nut driver, 10mm wrench.

Two people are recommended for bumper removal and re-installation.



ATTENTION: This Installation requires the removal of the front bumper. It is highly recommended to use two people for removal and re-installation.

A1/A2/A3/A4

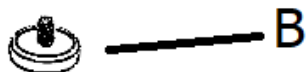
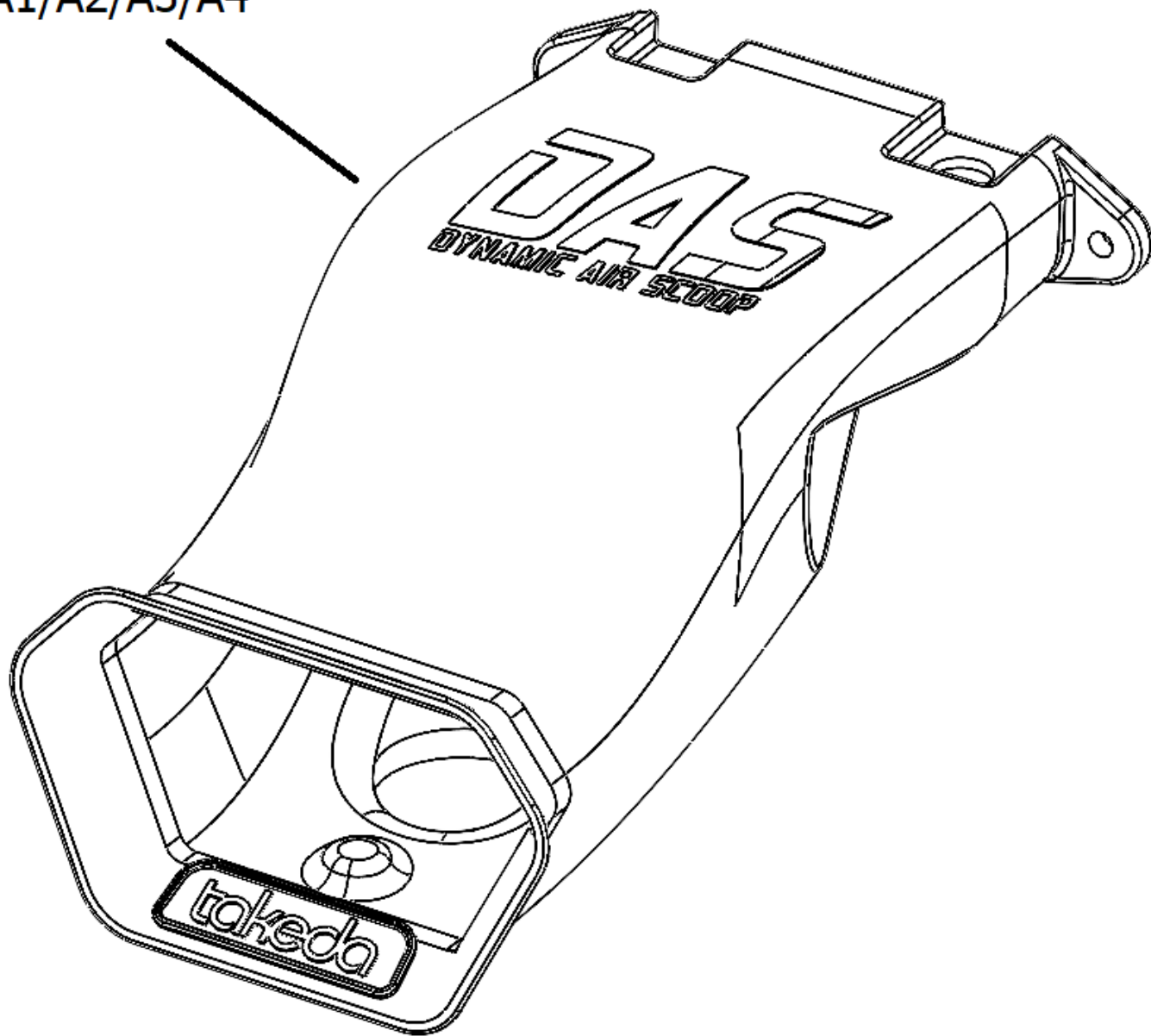



Figure A

Refer to Figure A for Step 1

Step 1: Lift the hood of the vehicle. Using the flat-blade screwdriver or a plastic trim tool, remove the six push rivets on the top side of the bumper. Remember to save the push rivets, they will be needed for re-installation.

**Figure B**

Refer to Figure B for Steps 2-3

Step 2: Using the same tool used in the previous step, remove the three push clips where the inner fender liner meets the bumper on the passenger side.

Step 3: Using an 8mm nut driver or socket, remove the screw in the fender. Keep this screw, it will be needed for reinstallation.

Repeat Steps 2 and 3 on the driver side.

**Figure C****Refer to Figure C for Step 4**

Step 4: Underneath the bumper, remove the six push clips along the front edge.



Refer to Figure D for Step 5

Step 5: Two people are recommended for this step. With all the push clips and both screws removed, gently but firmly pull on the fender sides of the bumper.



Refer to Figure E for Step 6

Step 6: Two people are recommended for this step. Once the sides of the bumper are loose, gently but firmly pull out on the bumper under the headlights. Be sure to hold the bumper securely, as it will want to fall to the ground once these clips are loose.

**Figure F****Refer to Figure F for Step 7-8**

Step 7: Before the bumper is fully removed, disconnect the turn signal wiring harnesses on both sides.

Step 8: The bumper is now able to be set aside. Be sure to rest the bumper on a surface that will not damage the paint or undershirt.

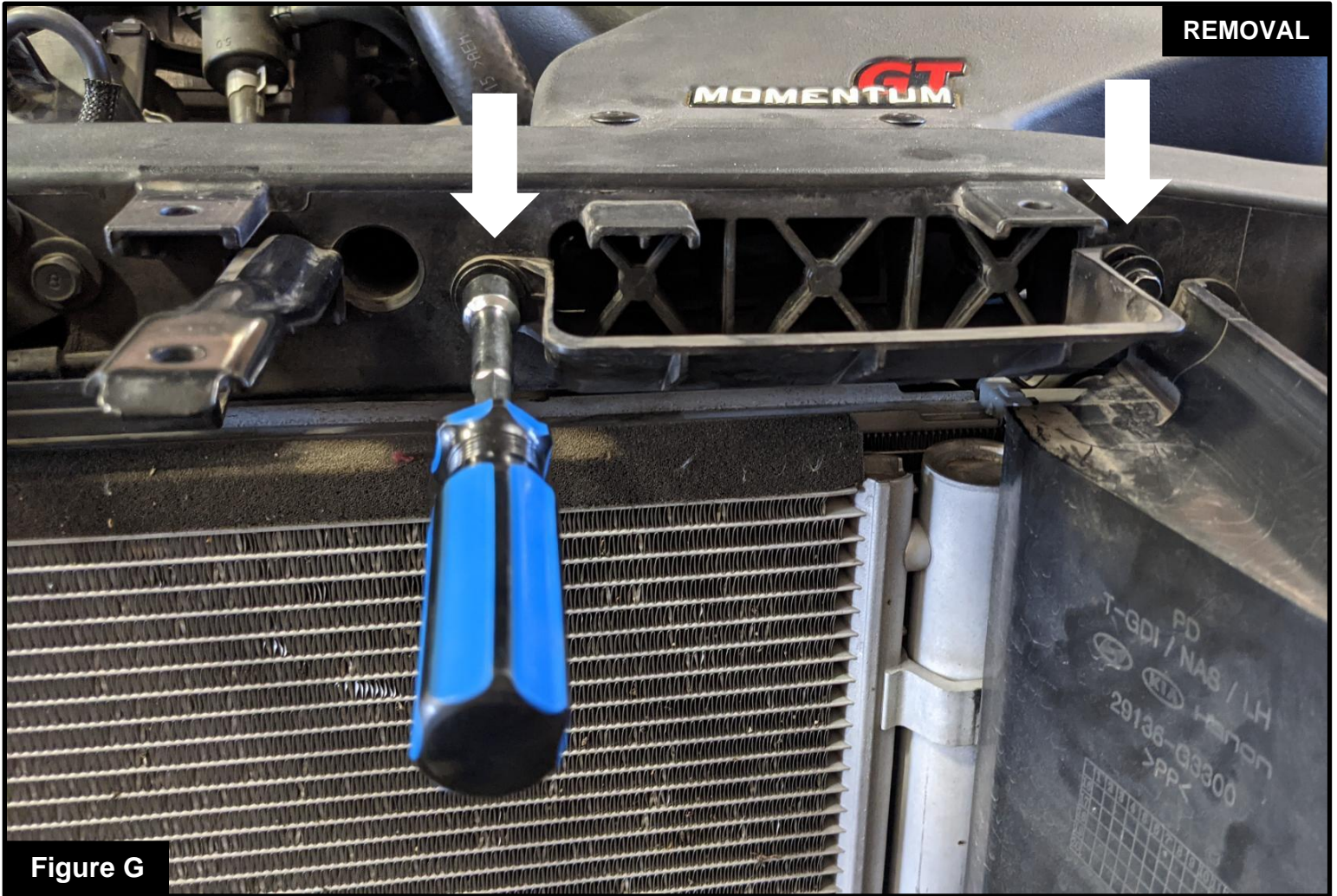

Refer to Figure G for Step 9

Step 9: Using a 10mm nut driver or socket, remove the screws holding the factory scoop. Keep the screws, they will be re-used for installation of the Takeda Dynamic Air Scoop.

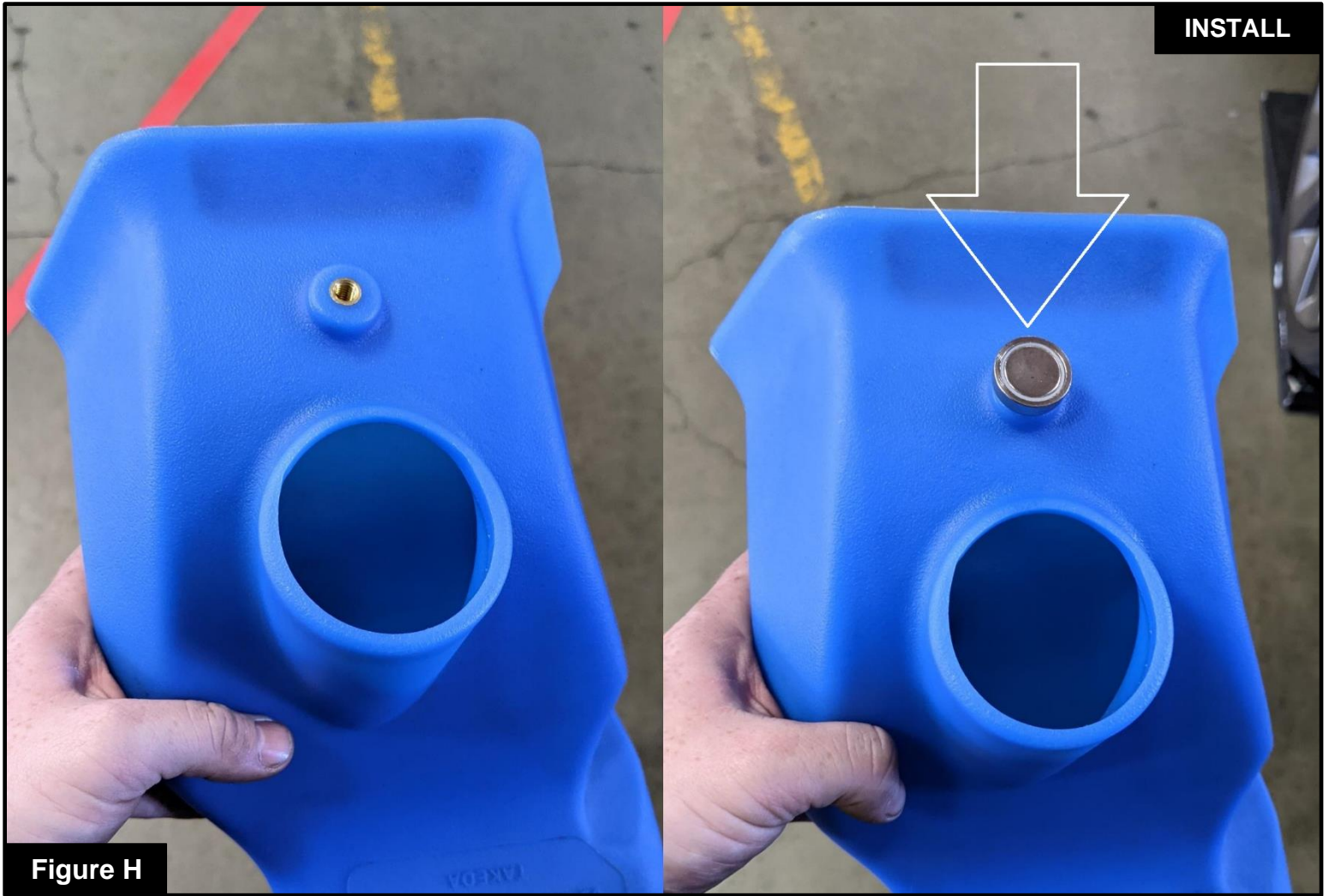

Refer to Figure H for Step 10

Step 10: Install the studded magnet into the threaded insert on the bottom of the Takeda Dynamic Air Scoop. No tool is needed for this, only tighten it by hand.

**Figure I****Refer to Figure I for Step 11**

Step 11: Line up the mounting holes on the Takeda Dynamic Air Scoop with the factory threaded holes on the radiator support. The magnet will hold the Takeda Dynamic Air Scoop to the interior bumper.



Refer to Figure J for Step 12

Step 12: Re-using the factory scoop screws removed in step 9, secure the Dynamic Air Scoop with a 10mm nut driver/socket and a 10mm wrench.

**Figure K**

Refer to Figure K for Steps 13-14

Step 13: Using Steps 1-9, carefully re-install the bumper onto the vehicle and reconnect the turn signals.

Step 14: Your Takeda Dynamic Air Scoop is now installed, Thank you for choosing Takeda!



Pro DRY S Air Intake System



P/N: 56-70005D

Pro 5R Air Intake System



P/N: 56-70005R

SPRINT BOOSTER



P/N: 77-17001

Twisted Steel Down Pipe w/cat



P/N: 48-37001-HC

Track Series Air Intake System



P/N: 57-10006R

Pro 5R Intake System



P/N: 54-76305-CF

Takeda 3" to 2.5" Cat-Back Exhaust

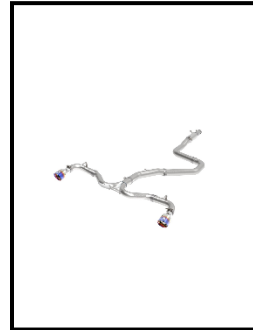

P/N: 46-20198-B

SCORCHER GT Power Module



P/N: 77-47001

Magnum Flow OE Replacement



P/N: 30-10323

[View other performance exhaust systems made by Takeda on our website.](#)