

**advanced FLOW engineering**  
**Instruction Manual** P/N: 56-70003D / 56-70003R



Make: **Honda** Model: **Accord** Year: **2018-2019** Engine: **I4-2.0L Turbo**



- Please read the entire instruction manual before proceeding.
- Ensure all components listed are present.
- Ensure you have all necessary tools before proceeding.
- Do not attempt to work on your vehicle when the engine is hot.
- Disconnect the negative battery terminal before proceeding.
- Retain factory parts for future use.

## Retain factory parts for future use.

Label	Qty.	Description	Part Number
A1	1	Air Filter (Pro DRY S)	21-91103 (Grey Media)
A2	1	Air Filter (Pro 5R)	24-91103 (Blue Media)
B	1	Tube	05-5670003B1
C	1	Housing	05-5670002B2
D	1	Coupling, Silicone Reducer	05-01455
E	2	Clamp, #044	03-50019
F	2	Screw, Torx: M4	03-50491
G	4	Retainer Clips	03-50525

### Installation will require the following tools:

Flat head screw driver, ratchet, 10mm socket, extension, 8mm nut driver

Note: Legal in California for use on race vehicles only. The use of this device on vehicles used on public streets or highways is strictly prohibited in California and others states that have adopted California emission regulations.

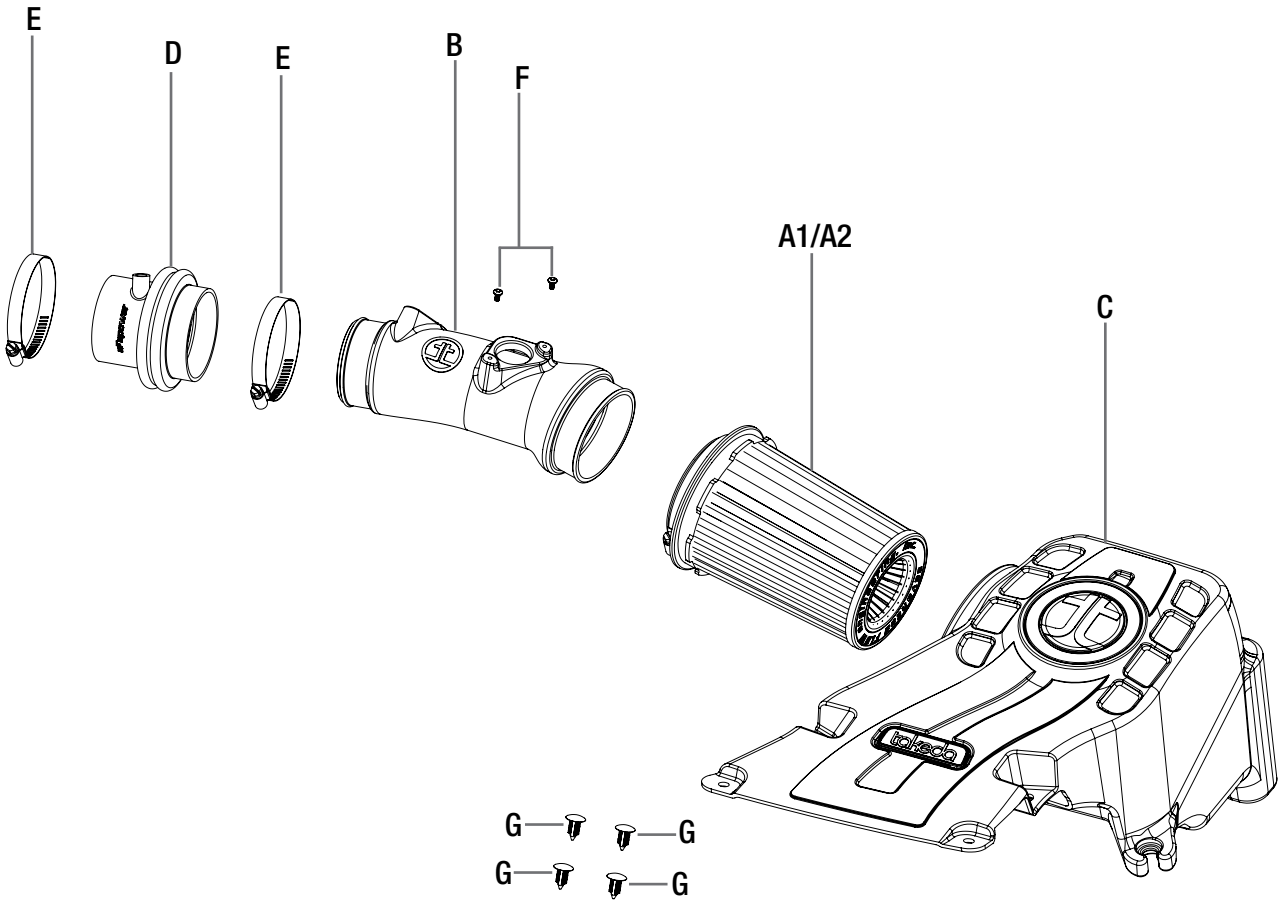

**Figure A****Refer to Figure A for Steps 1-4**

- Step 1: Disconnect the Mass Air Flow (MAF) sensor harness. ①
- Step 2: Unclip the MAF harness from the factory intake housing. ②
- Step 3: Remove the 4 push clips securing the factory intake scoop. ③
- Step 4: Pull intake scoop out of vehicle.



Figure B

**Refer to Figure B for Steps 5-7**

Step 5: Loosen the clamp on the factory coupling connecting to the turbo inlet.

Step 6: Disconnect both hoses from the purge jet (4).

Step 7: Pull the crankcase line out of the factory coupling (5).



**Refer to Figure C for Steps 8-9**

Step 8: Remove the two 10mm screws securing the factory intake housing (6) to the car. (one bolt will be reused in a later Step)

Step 9: Take the factory air intake system assembly out of the vehicle by pulling it out of the factory grommet.

**Figure D****Refer to Figure D for Step 10-11**

Step 10: Pre-install the air filter into the Takeda housing, make sure the filter locks in by pushing it firmly into the housing.

Step 11: Transfer one of the factory grommet with metal sleeve onto the Takeda housing along with the push-on grommet into the hole at the bottom of the housing.



Figure E

**Refer to Figure E for Steps 12-14**

- Step 12: Install the Takeda housing into the vehicle by pushing it into the factory mounting peg. Secure the housing with one of the factory screw (removed at Step 8).
- Step 13: Install the 4 provided Christmas tree clips to secure the inlet part of the housing.
- Step 14: Insert the crankcase line into the supplied coupling, then install it over the turbo inlet. Install the clamps on the coupling but do not tighten yet.





Figure F

**Refer to Figure F for Steps 15-16**

Step 15: With a 10mm socket or nut driver, remove the purge jet off the factory intake tube and transfer it to the Takeda intake tube. Secure it with the factory screws.

Step 16: Using a Philips screw driver, remove the MAF sensor from the factory intake tube and transfer it to the Takeda intake tube. Secure it using the supplied torx screws.

**Figure G**

### **Refer to Figure G for Steps 17-21**

Step 17: Slide the Takeda intake tube into the air filter then into the coupling.

Step 18: Reconnect the harness to the MAF sensor.

Step 19: Reconnect the two hoses on the purge jet accordingly

Step 20: Align the intake tube with the air filter and coupling, then tighten all clamps.

Step 21: Make sure all clamps and connections are secured. Your installation is now completed.

**NOTE: Check all bolts, clamps and connectors after 100-200 miles.**

[Learn more about other performance air intake systems by Takeda on our website.](#)