



INSTALLATION INSTRUCTIONS

Cat-Back Exhaust

MAKE: Hyundai
MODEL: Veloster N
YEAR: 2019-2020
ENGINE: L4-2.0L (t)

49-37010-B
 49-37010-P

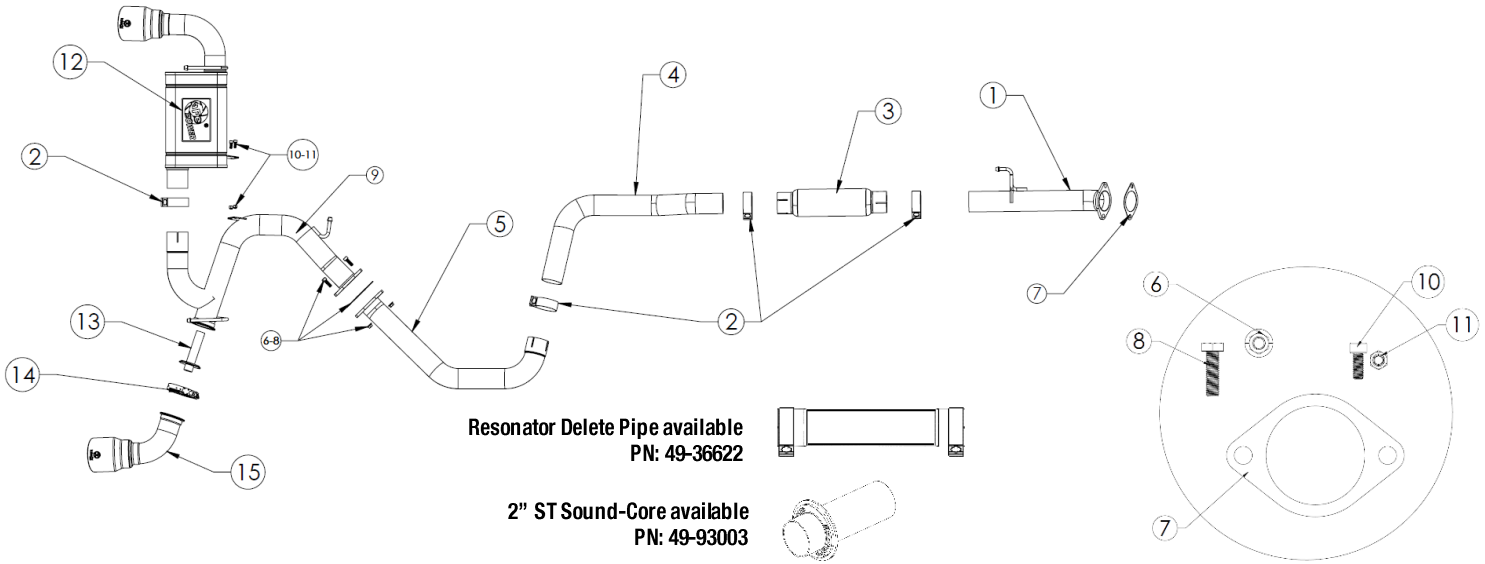

Item	Description	Part Number	Quantity
1	Race-pipe Assembly	05-145771	1
2	3" Band Clamp	05-41055	4
3	Resonator	05-145193	1
4	Mid-pipe 1	05-145772	1
5	Mid-pipe 2 Assembly	05-145773	1
6	M10 x 1.5 Flanged Nut	03-50189	2
7	Gasket	05-46400	2
8	M10 x 1.5 x 35 Hex Head Cap Bolt	03-50452	2
9	Branch Assembly	05-145905	1
10	M8 x 1.25 x 16 Socket Head Cap Screw	03-50171	2
11	M8 x 1.25 Acorn-Lock Hex Nut	05-46057	2
12	Muffler Assembly w/ Polished Tip	05-145775P	1
12	Muffler Assembly w/ Black Tip	05-145775B	1
13	1-1/4" ST Sound-Core	05-145907	1
14	V-band Clamp	05-41588	1
15	PS Tailpipe Assembly w/ Polished Tip	05-145906P	1
15	PS Tailpipe Assembly w/ Black Tip	05-145906B	1

aFe POWER recommends professional installation on this product. Thoroughly inspect the aFe POWER exhaust system to make sure there is no damage from shipping (if damage is noted, immediately contact aFe POWER customer service). Allow time for your vehicle to cool down prior to installation. When working on your vehicle proceed with caution. Wear protective safety equipment; eye goggles and gloves to ensure a safe installation.

Install band clamps to proper torque specifications of 40-45 ft-lb.



INSTALLATION INSTRUCTIONS

MAKE: Hyundai
MODEL: Veloster N
YEAR: 2019-2020
ENGINE: L4-2.0L (t)

Cat-Back Exhaust

49-37010-B

49-37010-P

1. **(Read instructions prior to installation.)** It is recommended to not fully tighten the exhaust until it has been fully installed. Leave loose for adjustability.
2. Secure vehicle on jack stands (refer to your manual for specified jack stand positions).
3. For faster installation, spread out the parts of the exhaust alongside your vehicle as shown in the diagram above.
4. Secure the stock exhaust with jack/stands.
5. Loosen the (x2) nuts securing the muffler assembly to the OE mid-pipe.
6. Remove the (x3) isolation mounts on the muffler assembly using hanger pliers or a pry bar and remove the OE muffler assembly.
7. Loosen the (x2) nuts securing the mid-pipe to the downpipe.
8. Remove the (x1) isolation mount on the mid-pipe using hanger pliers or a pry bar and remove the OE mid-pipe.
9. Using the provided gasket and the OE (x2) nuts, install the Takeda Race-pipe Assembly.
10. Slide the hanger on the Takeda Race-pipe into the OE isolation mount.
11. Install the Takeda resonator using the supplied (x2) 3" band clamps.
12. Install the Takeda Mid-Pipe 1 using the provided 3" band clamp.
13. Install the Takeda Mid-Pipe 2 Assembly using the provided 3" band clamp.
14. Assemble the Takeda Muffler Assembly and Takeda Tailpipe outside of the vehicle using the supplied 3" band clamp, 3" V-Band, (x2) M8 nuts and (x2) M8 bolts. **See reference image (2) for bracket orientation.** Note: At this time, you can choose to install the 1-1/4" ST Sound-Core if you would like.
15. Install the Takeda Muffler and Tailpipe section to the Takeda Mid-pipe section using the supplied gasket, (x2) M10 bolts and (x2) M10 nuts.
16. Ensure that all the components of the Takeda exhaust system are aligned and are at a safe clearance from all wires, hoses, brake lines, body parts, and tires.
17. Start from the front of the Takeda exhaust system and evenly tighten all clamps and fasteners.
18. Start the vehicle and check for any leaks. If any leaks are found, determine cause and repair as necessary.
19. Remove vehicle from jacks stands.
20. It is recommended to re-tighten all clamps and hardware after 50-100 miles.

