

**INSTRUCTIONS:**

1. Assembling the 5 Bike Rack (diagram 1).
  - a. Slide rack 'C' into collar 'B'. Secure in place with 12mm x 80mm bolt, washers and lock nut.
  - b. Torque the nut using a 19mm wrench. It should be tight enough to allow for movement of the rack in the collar to fold down as required. **NOTE:** The locknuts are a special machine nut, they require force to tighten.
  - d. Place a 1/2" Pin and clip through the hole above.
  - e. Slide the receiver piece 'A' into collar 'B'. Secure in place with two 12mm x 80mm bolts and lock nuts.
  - f. Torque the nuts on tightly using a 19mm wrench. (45 lbs)
  - g. Periodically check to make sure that all bolts, lock nuts, pins and clips are in place and secure.
2. Insert your 5 Bike Rack receiver into your receiver hitch\* (diagram 3). Tighten the threaded pin and install clip.
3. Fit rack as close to the vehicle as possible.
4. Check to ensure rack is secure and safety pin is in place.
5. After placing a maximum of 5 bikes on your rack, replace top plate and tighten knobs evenly.

**CRADLE INSTRUCTIONS (DIAGRAM 2):**

1. Remove the large black vinyl from the cradle exposing the nuts on the "C" clamps
2. Remove the nuts and pull off the "C" clamp
3. Push the "C" clamp under the top tube facing upward; install the tube bracket and then the cradle. Position the locking cradle furthest from the rear of the vehicle and no further than within 1" of the end of the tubing. Locking cradle goes on the outside position.
4. The cradles can be individually positioned in several locations. This will allow the cradles to be angled so that when bikes are installed the tires will be level to the ground.
5. Install the two nuts and tighten equally so that no threads are showing on the top of each nut. Periodically check to ensure that they are tight. **NOTE:** If one nut is tightened more than the other, the threads will protrude through the vinyl causing damage to the bike frames.
6. Install the bikes and tighten down the top plates. Ensure that the spacer on the knob goes into the round slot in the top plate. **NOTE:** Extreme force can be generated by the top plates so don't over tighten the knobs or frame damage will occur.
7. A tether strap is supplied and should be used if excessive rack movement is noted. It is mounted on the cradle closest to the vehicle. The fixing plate is mounted between the Bike Rack Tube Gripper Plate and the metal cradle. The tether strap clip is inserted into the slot on the fixing plate. The webbing strap is wrapped through a point on the vehicle and back through the metal spring loaded buckle. There is a lot of length on the strap to allow for many different mounting locations. Each vehicle is different so you will need to find a secure location. Tighten the strap and tie off the extra length of webbing to prevent it from flapping in the wind and loosening up. Periodically check the strap to insure that it is tight, especially if it gets wet.
8. The warrantee will be voided if the rack is overloaded with more bikes than the rack was intended for.

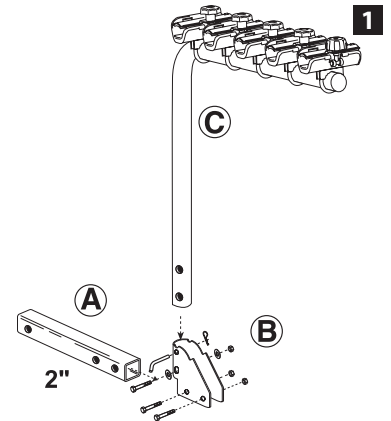
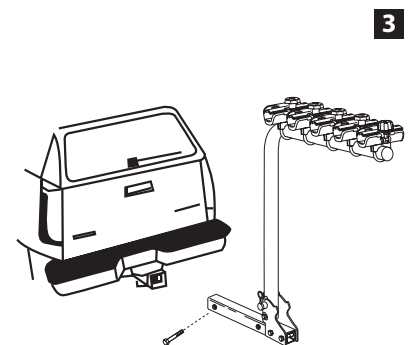
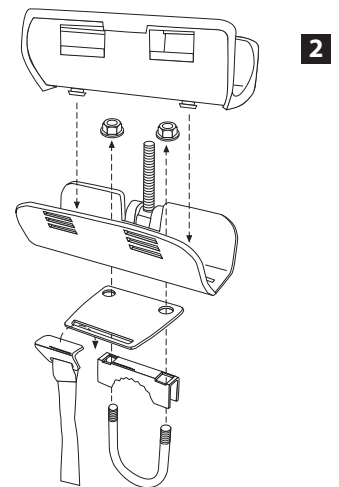

**IMPORTANT NOTES**

- This bicycle rack has been designed to carry 1, 2, 3, 4 or 5 bikes.
- This rack is designed for typical use and applications (on paved or smooth gravel roads). Do not use this rack on a vehicle that will be driven on rough roads or where the rack (and bikes) will be subjected to significant or constant jarring and/or shock, or any vehicle with very stiff springs that will transfer the load shocks directly to the rack and the bikes.
- Proper fitting and installation of this carrier to your specific vehicle is critical, and is the owner's sole responsibility.
- Improper use of this product may result in damage to your rack, your vehicle, your bicycles, or even other vehicles driving behind you (as a result of colliding with or trying to avoid fallen bicycles and/or the rack).
- The purchaser should be aware that the load created by a rack and bicycles can exceed the maximum rating on the hitch or bumper.
- Swagman racks are powder coated to help prevent rust. When leaving the rack outside for extended periods of time the finish will lose its luster. It is recommended that the rack is washed periodically to remove road grime, salt, etc. when not in use stored indoors.
- The rack won't carry bikes with oblong frame tubes or unusually large frame sizes.
- Take care to add padding on any area of the bikes that touches another bike or any part of the vehicle. Damage can and will happen (to your bikes and/or to the vehicle) if care is not taken during the loading and transporting of your bikes, and padding used where necessary.
- Bicycle tires should be kept at least 6" away from the exhaust pipes of the vehicle. The high temperature exhaust exiting from the exhaust pipes is hot enough to melt or damage tires. Keep all bike tires totally away from the direct exhaust flow.
- Bikes fitted with large accessories (such as child carrying seat) will greatly increase the wind resistance and therefore the pressure on the rack and all vehicle mounting points. Reducing vehicle speed will reduce the chance of any problems occurring because of this situation.

**Mounting the Bike Rack on a trailer or 5th wheel**

1. Purchaser is advised that the load created by rack and bicycles may exceed the strength of trailer or 5th wheel bumper or other mounting location. Failure through improper mounting will void rack warranty.
2. Fold down racks are NOT covered under warranty if mounted on the back of fifth wheels or trailers.

** WARNING**

1. This bike rack is designed to be used on bike frames that have straight round tubing. It should NOT be used when clamping on irregular shaped tubes that are curved, oblong, rectangular, etc., for instance those commonly seen on cruiser style bikes.
2. Bike frames made out of a composite material or carbon fiber should NEVER be clamped in this style of rack because the Bike Manufacturer may void your warranty.