

# UPRIGHT ROOF RACK

64XXX

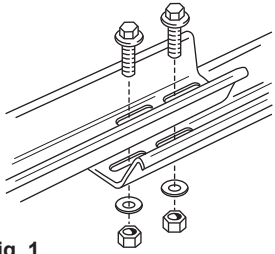

fig. 1

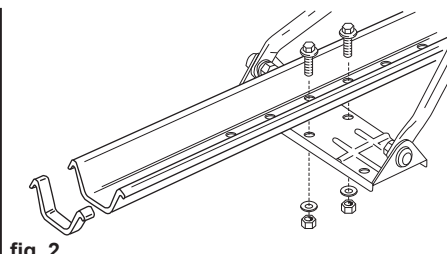

fig. 2

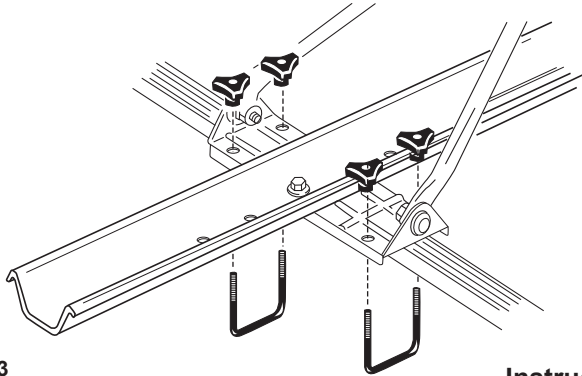
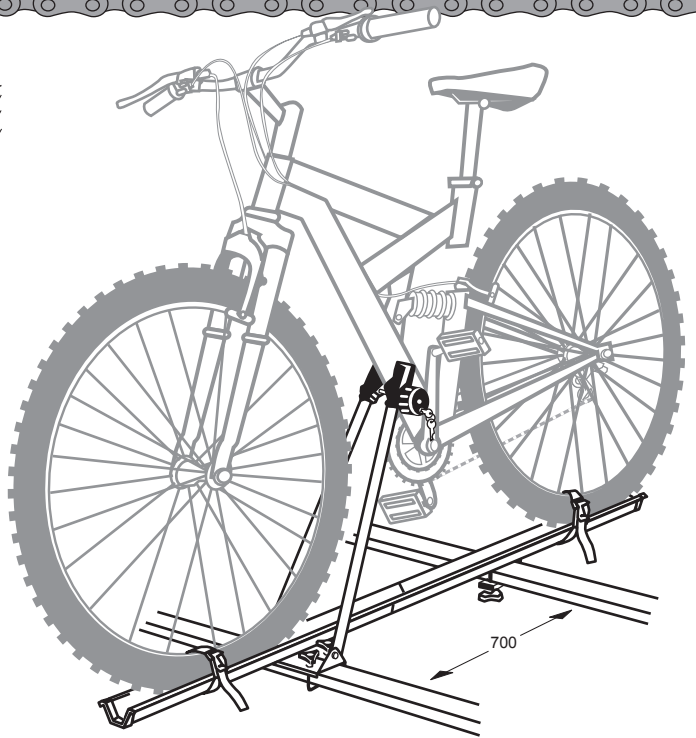

fig. 3

## Instructions:

First assemble the wheel tray using the two nuts/bolts/washers provided, see fig. 1. Assemble the plastic end protectors and the bike support brackets as in fig. 2. If your bike is not "centered" on the wheel tray then you should adjust by moving the bike support arm bracket along the wheel tray using the two fixing nuts/bolts. If you do this make sure the nuts are re-tightened firmly.

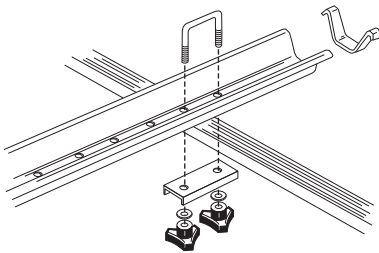

fig. 4

Next attach the bike support arm bracket to your front roof bar using the "U" bolts provided, see fig. 3. Then attach the rear bar to the wheel tray using the "U" bolt and bracket shown in fig. 4. Insert the plastic protectors into the bike clamp jaws, see fig. 5. Place your bike into position and attach the clamp to the bike's front downtube. The knob should be firmly tightened. The angle between the support arm and your bike's downtube should be approximately 90 degrees (right angle) see fig. 6. Lastly use the two wheel straps provided to place around the wheels and wheel tray and pull tight see fig. 7.

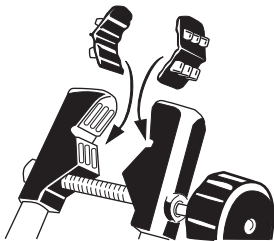

fig. 5

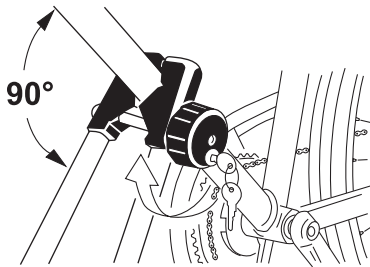

fig. 6

You should remember some important points when using a bike carrier:

- All nuts and bolts should be checked for tightness after assembly and at regular intervals.
- Check REGULARLY that the knob fixing the clamp to your bike's downtube is tight.
- Remove all accessories from your bike especially child seats, panniers, lights, etc..
- Remember that you are carrying a bike on your roof and your car's handling characteristics will differ, so GO SLOWER than normal, especially in high winds and around bends. Keep your speed below 60mph.
- Do not forget your vehicle will be much higher than normal so be care that you have enough room when entering tunnels, car parks and especially your garage!
- Never exceed the vehicle manufacturers recommended maximum weight limits and ensure that no part of the bike extends outside the vehicles widest point.
- We would suggest you remove the carrier when not in use, as this is safer and saves gas.

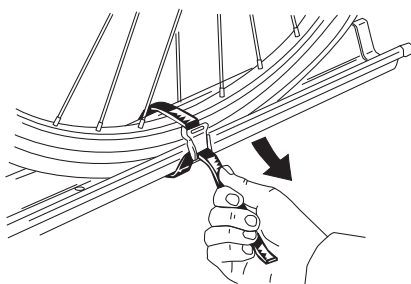

fig. 7

**Swagman cannot accept responsibility for damage caused by incorrect fitting.**

The total weight of this carrier is approx 3 kg (6.6 lbs)

