

INSTALLATION

1. Install the front wheel tray using the Allen screws and nuts provided (diagram 1).
2. Remove the 4 wing nuts on the front and 2 on the rear crossbar mounts and take off the lower crossbar clamp (diagram 2).
3. Position the front clamp onto the front crossbar. Attach the crossbar clamp and loosely attach the 4 wing nuts (diagram 3).
4. Slide the rear crossbar mount into position over the rear crossbar. Attach the crossbar mount and loosely attach the 2 wing nuts (diagram 3).
5. Move the rack from side to side on the crossbars to ensure it is perpendicular with the vehicle.
6. Once it is the correct position tighten the 6 wing nuts.

NOTE 1: You may encounter a situation where you will want to move the rear wheel strap in front of the rear crossbar mount. This may be necessary if you have a very short wheel base bicycle or the crossbars are quite far apart. You will need to slide the rear crossbar mount off the back of the rack, then install the wheel strap on the extrusion followed by replacing the rear crossbar mount (diagram 4). You need to remove the two small Allen bolts that hold on the end cap so that the parts can slide off.

LARGER CROSS BARS

1. Remove the two Allen bolts holding the front crossbar mount onto the extrusion.
2. Remove the 4 small bolts from the front crossbar mount. (You won't need these).
3. Take the two bolts from the rear mount, plus the two shorter bolts in the package and install the front mount.
4. Take the two long bolts in the package and put these into the rear mount plate.

LOADING BIKES

1. Move the ratchet arm forward. Push the ratchet release and move the ratchet hook assembly to the end of the ratchet arm (**NOTE 1**).
2. Put the bike into the wheel trays with the front wheel in the upswept wheel tray.
3. While holding the bike rotate the ratchet arm upward towards the fork crown.
4. Position the hook assembly tight against the fork crown or front brake of the bike (diagram 5). **NOTE:** Failing to have the hook tight against the crown of the fork can cause the bike to dislodge.

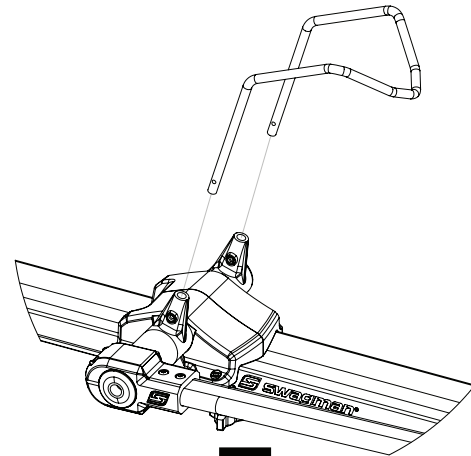
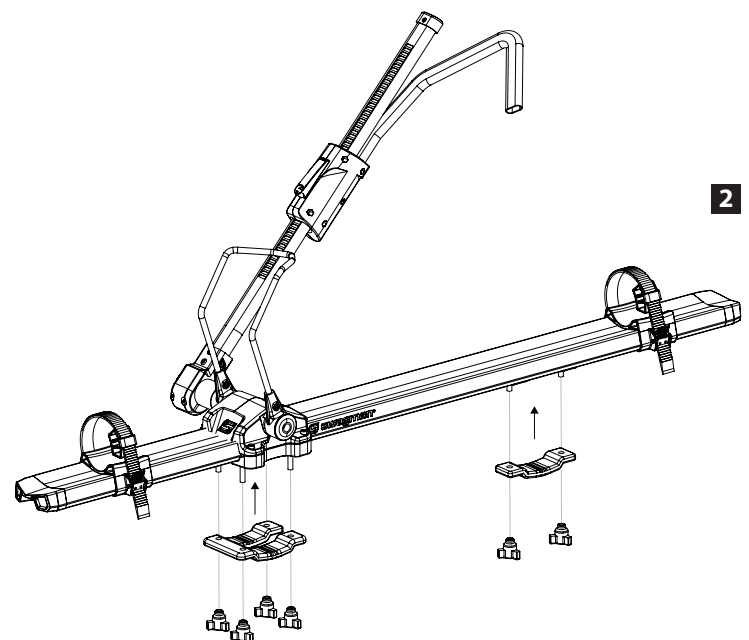
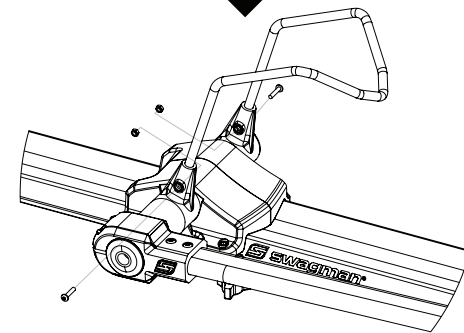
1

2

5. Pull the hook downward so that the hook is tight against the tire. After the hook contacts the tire push down hard until you hear an extra click in the ratchet release. **NOTE:** The hooks should be tight against the fork crown and the tire. Move the bike back and forth to ensure it is fully seating. Readjust if necessary.
6. Move the rear wheel holder so it is positioned in the center of the tire (diagram 6).
7. Push the strap through the buckle and pull the strap tight.
8. Repeat 6 and 7 on the front wheel holder.

NOTE: On smaller wheels you will need to use the space block.

LOCKING BIKES

1. To lock your bikes rotate the key in the ratchet hook so the button cannot be depressed (diagram 7).
- NOTE:** Never leave your bikes unattended for any length of time. Locks are meant as a deterrent and won't prevent bike theft.
2. When the rack is not in use the ratchet arm can be folded down and secured with the rear wheel holder strap.

⚠ IMPORTANT NOTES:

- Bicycle fork must have safety tabs.
- Remember that you are carrying a bike on your roof and your car's handling characteristics will differ, so **GO SLOWER** than normal, especially in high winds and around bends. Keep your speed below 60mph.
- Do not forget that your vehicle will be much higher than normal, so be care that you have enough room when entering tunnels, car parks and especially your garage!
- Never exceed the vehicle manufacturers or after market crossbars recommended maximum weight limits.
- Do not transport bicycles with baby carriers, panniers, disk wheels/wheel cover or bike covers as it can increase the load on the crossbars and bike rack.

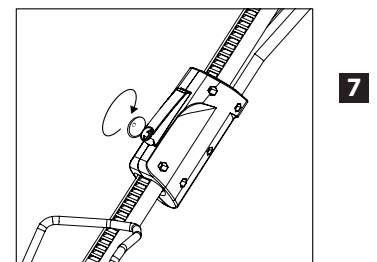
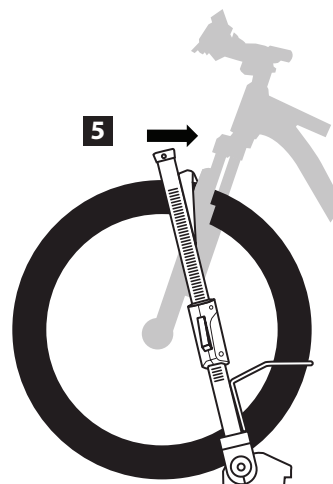
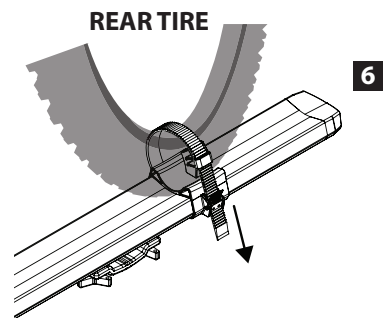
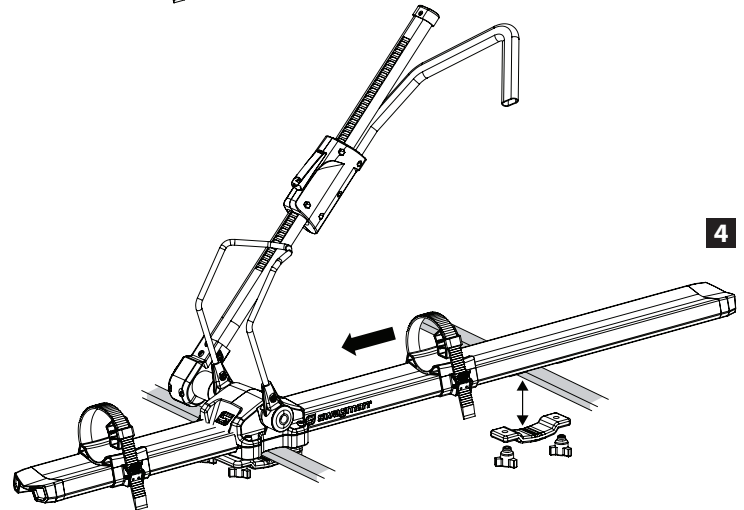
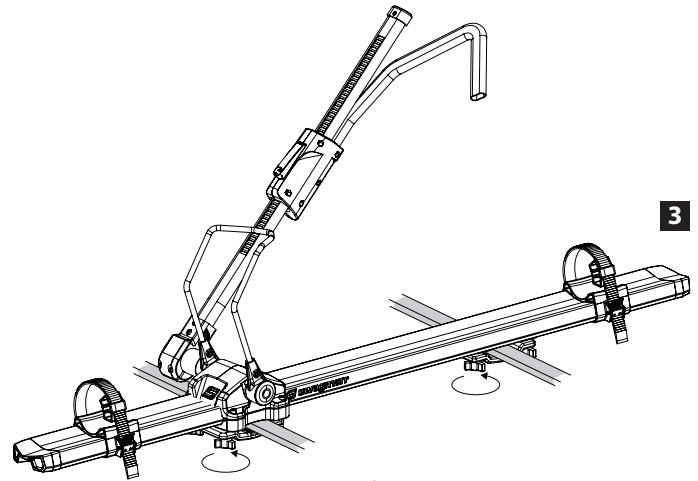

1. How to change the rack from a Passenger side to Driver side loading.



5. Remove the two Allen bolts holding on the wheel cage.
Note: Do not lose the nuts on the backside.



2. Using the supplied tool hold the insert and unscrew.



6. Remove the Wheel cage.



3. Using an Allen Key remove the two bolts holding the ratchet arm assembly on.



7. Remove plastic spacer.



4. Using an Allen Key remove the limiter bolt. Set ratchet arm assembly aside.



8. Remove the two wheel cage holders.



9. Unscrew the 4 bolts holding the unit onto the extrusion.



10. Turn the unit upside down and remove the two bolts holding the aluminum shaft into the plastic mount.



11. Slide the aluminum shaft so it aligns up with the two holes on the opposite end of the shaft.



12. Re-install the two bolts previously removed and tighten.



13. Re-install the bracket back onto the aluminum extrusion.



14. Install the wheel cage holders.



15. Re-install the two screws to hold on the wheel cage.



16. Slide on the plastic shim.



17. Install ratchet arm assembly and insert limiter bolt.



18. Install and tighten the two Allen bolts. Adjust the tension using these two Allen bolts.



19. Install end caps.



20. Tighten using the supplied tool.

