

**INSTALLATION**

1. Remove the 4 wing nuts on the front and 2 on the rear crossbar mounts and take off the lower crossbar clamp (diagram 1).
2. Position the front clamp onto the front crossbar. Attach the crossbar clamp and loosely attach the 4 wing nuts (diagram 2).
3. Slide the rear crossbar mount into position over the rear crossbar. Attach the crossbar mount and loosely attach the 2 wing nuts (diagram 3).
4. Move the rack from side to side on the crossbars to insure it is perpendicular with the vehicle.
5. Once it is the correct position tight the 6 wing nuts.

**Note:** You may encounter a situation where you will want to move the wheel strap in front of the rear crossbar mount. This may be necessary if you have a very short wheel base bicycle or the crossbars are quite far apart. You will need to slide the rear crossbar mount off the back of the rack, then install the wheel strap on the extrusion followed by replacing the rear crossbar mount (diagram 4).

**INSTALLING THE BIKES:**

1. Remove the front wheel from the bike. Insert the fork blade into the bike mount bracket with the QR lever (not supplied) in the open position, hand tighten the nut on the opposite side of the lever.
2. Then close the QR lever so that the fork is tight in the bike support bracket. Move the bike back and forth to ensure that the fork is tight in the bracket.
3. Slide the rear wheel strap holder in position and attach the wheel strap. Pull the strap snug and test to ensure it is tight. Avoid putting the strap through the area where there is the valve stem.

**⚠ IMPORTANT NOTES:**

- Bicycle fork must have safety tabs.
- Remember that you are carrying a bike on your roof and your car's handling characteristics will differ, so **GO SLOWER** than normal, especially in high winds and around bends. Keep your speed below 60mph.
- Do not forget that your vehicle will be much higher than normal, so be care that you have enough room when entering tunnels, car parks and especially your garage! Never exceed the vehicle manufacturers or after market crossbars recommended maximum weight limits.

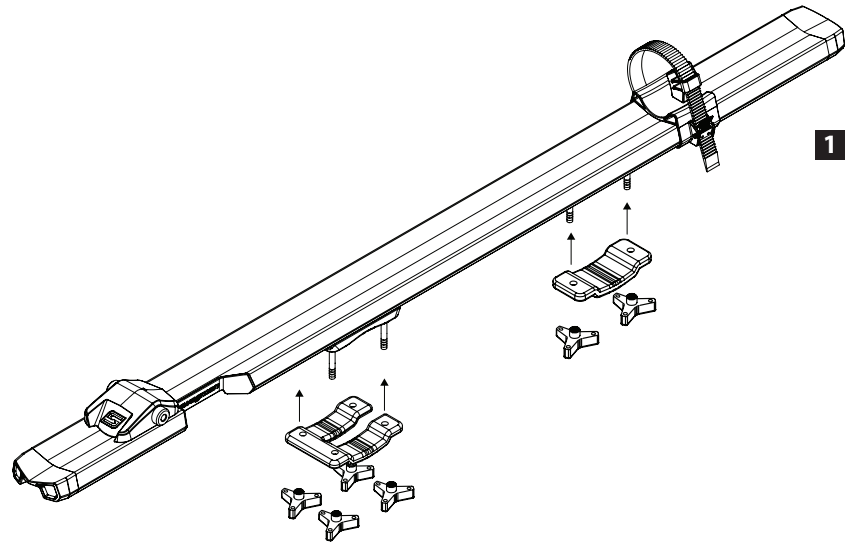
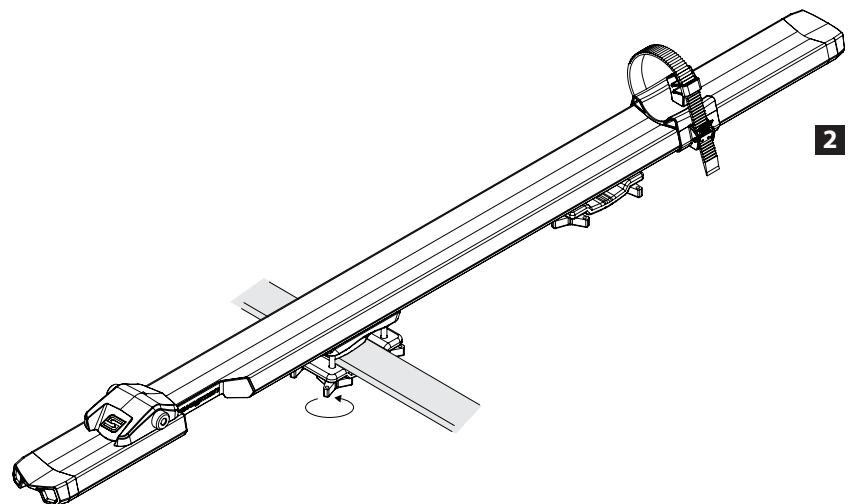
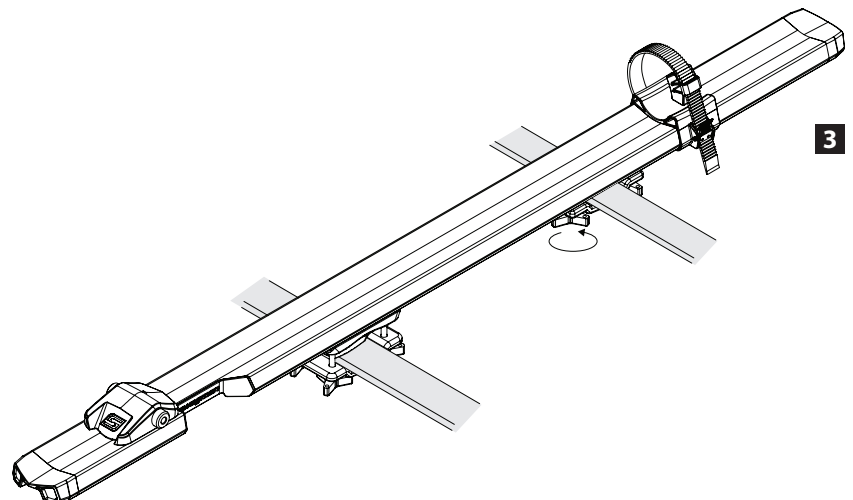
**1**

**2**

**3**

- Do not transport bicycles with baby carriers, panniers, disk wheels/wheel cover or bike covers.
- All nuts and bolts should be checked for tightness after assembly and at regular intervals.

**Note:** Not to be used with bikes that have carbon fiber dropouts.

## INTERCHANGEABLE AXLES

The rack comes with the 9mm installed.

If you are using the Enforcer with a 15mm thru axle you will need to remove the 9mm QR lever and adapter. Using the supplied Allen key, loosen the set screw at the side of the fork block. Slide the 9mm axle out and replace with the 15mm axle adapter. Line up the axle and tighten the set screw. You need to use your bike thru axle if mounting a 15mm or 20mm fork.

The rack has an optional interchangeable axle to fit 20mm thru Axles and 150mm x 15mm thru axle with score line at 142mm and 138mm for assorted Fat Bike Dropout widths (diagram 6).

