

Assembly Instructions:

1. Remove the small cover on the extrusion. Attach two of the small metal plates onto the fork mount block using the two 6mm security bolts (diagram 1). Leave the bolts as loose as possible.
2. Holding the fork mount block, drop the plates into the cut-out in the extrusion (diagram 2). Slide the fork mount into the desired position (diagram 3). Use the supplied wrench to tighten.
3. Repeat with the second fork mount (diagram 4).

Additional fork mounts can be purchased separately.

4. These fork mounts can be moved to a different location by loosening the two 6mm security bolts, repositioning the mount and re-tightening. The fork mounts can be installed on the inner or outer extrusion. **NOTE:** Keep the special wrench in a secure place as you will need the wrench to move the mounts.

Installation:

1. Unlock and open the telescoping bar clamp. Slide the inner section out so that the end pads can sit on the bedrail of the truck (diagram 5).
2. Push the telescoping bar clamp down and lock (diagram 6).
3. Rotate the micro adjust knobs until the Patrol PU rack end pads are securely tightened against the bedrails.
4. Lock the "micro-adjust" knob so that it turns freely without loosening the pads.
5. Make sure both end pads are tight against the bedrail. If the end pads are not tight, unlock the "micro adjust knob" and turn clockwise a couple of turns.
6. Pull the rack back and forth to ensure that the pads do not slip.

Special mounting instructions if you have a bed liner:

1. The material used for bed liners is quite slippery and the end pads do not grip properly.
2. Install one pin into the end pads as shown (diagram 7).
3. You will need to drill a hole in the bed liner at the position of this pin. Each hole should be equal distance from the front of the vehicle.
4. Repeat the procedure above ensuring that the pin goes into the previously drill holes in the bed liner.

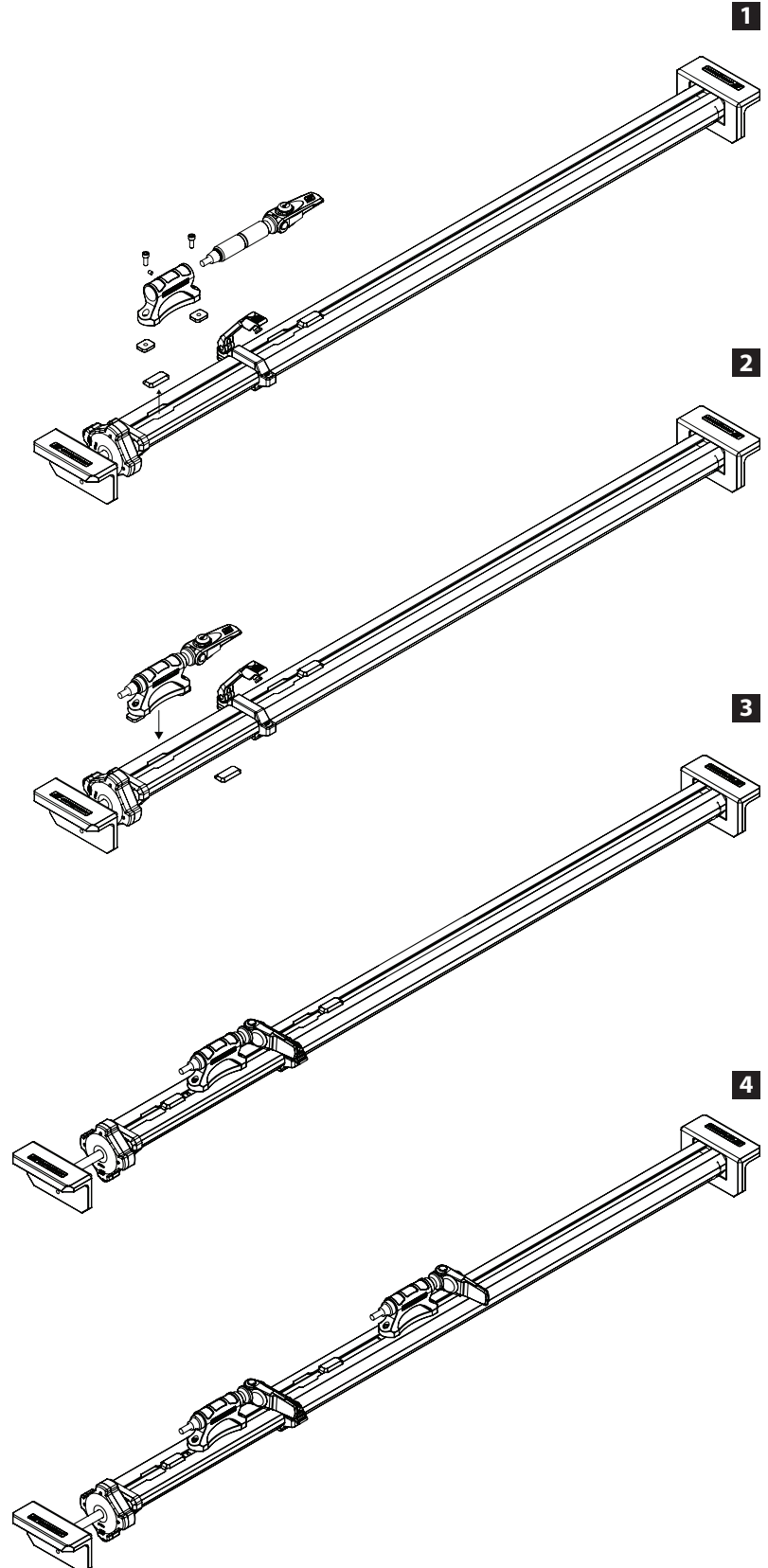

Installing the bikes:

1. Remove the front wheel from the bike.
Insert the fork blade into the bike mount bracket. With the QR lever in the open position, hand tighten the nut on the opposite side of the lever.
2. Then close the QR lever so that the fork is tight in the bike support bracket. Move the bike back and forth to ensure that the fork is tight in the bracket. Lock the QR Lever.

⚠ Important Notes:

1. Always keep the tailgate on the pickup closed when hauling bicycles.
2. You should remove large objects from the bicycle like child seats, panniers, or bike covers to reduce wind resistance.
3. Check periodically that the rack and bikes are securely attached.

Interchangeable axles

The rack comes with the 9mm installed.

If you are using the Enforcer with a 15mm thru axle you will need to remove the 9mm QR lever and adapter. Using the supplied Allen key, loosen the set screw at the side of the fork block. Slide the 9mm axle out and replace with the 15mm axle adapter. Line up the axle and tighten the set screw. You need to use your bike thru axle if mounting a 15mm or 20mm fork.

The rack has an optional interchangeable axle to fit 20mm thru Axles and 150mm x 15mm thru axle with score line at 142mm and 138mm for assorted Fat Bike Dropout widths.

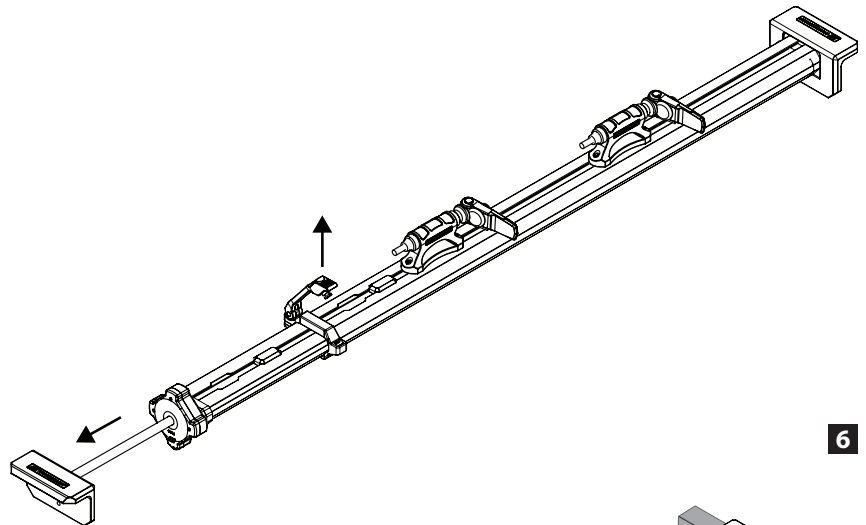
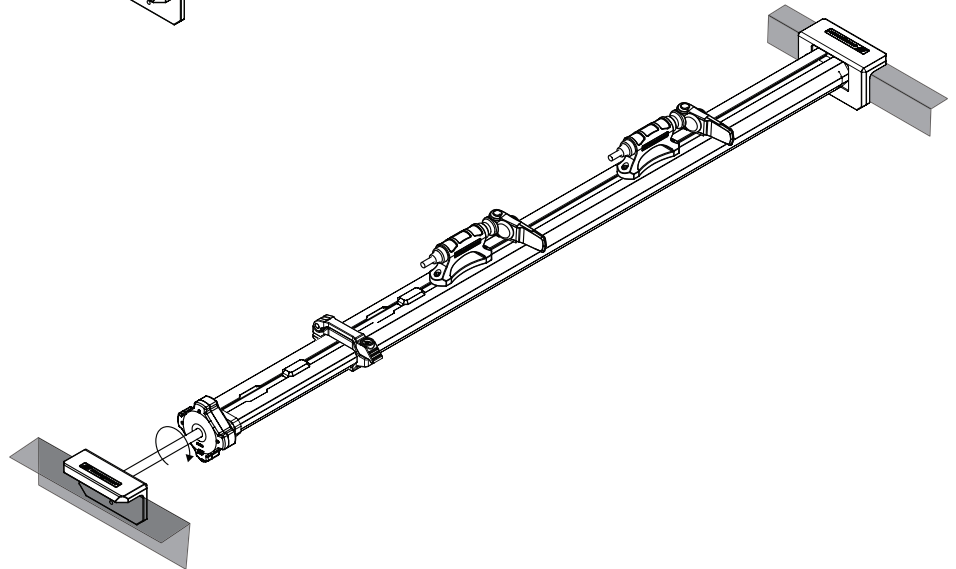
5

6

7
