

# INSTRUCTION SHEET

PRODUCT: 64678 Current ▪ Page 1 of 3



## Assembly Instructions

1. Remove main assembly (A) and cross bars (B) from box.
2. Assemble the crossbars (Diagram 1). The crossbar is made up of one male section and one female section. Make sure both square holes are positioned upward.
3. Align the ratcheting upright arm (C) onto the center section of the main assembly. Position it so that it folds to the left side when viewing from the back of the vehicle (Diagram 2). This will allow for easier use of the ratchet hooks. Secure with two 8MM x 70MM two carriage bolts, washers and nuts.
4. Place the assembled cross bars onto the main assembly so that the small set screw holes at the end of the bar are facing downwards. Insert the two 8MM x 45MM carriage bolts through the bracket, into the holes on the cross bars and secure with the washer and nut (Diagram 3). Note the orientation of the bars on the main assembly.
5. Repeat the same procedure with the second crossbar.
6. Install one long hook (D) and one short hook (E) onto the upright ratchet arm (Diagram 4). **NOTE:** the long hook goes on first. **NOTE:** depending on the bikes you may have to install the short hook first and then the long hook.
7. Slide the wheel trays (F) onto the cross bars (Diagram 5). The wheel trays should be orientated so that the high side of the tray is closest to the centre post of the rack and the buckles and knobs are facing the back of the rack. Your bike size will determine the best position for these 4 wheel holders. Review bike Installation for more details.
8. After all of the wheel trays are installed you will need to install the self tapping screws (G) into the underside ends of each crossbar (Diagram 5). **NOTE:** This will help prevent the wheel tray from sliding off if you forget to tighten the wheel tray knob when not in use.
9. If the rack is to be used on 1-1/4" receiver you will need to remove the Allen Bolt that holds on the spacers (Diagram 6).

## Parts List

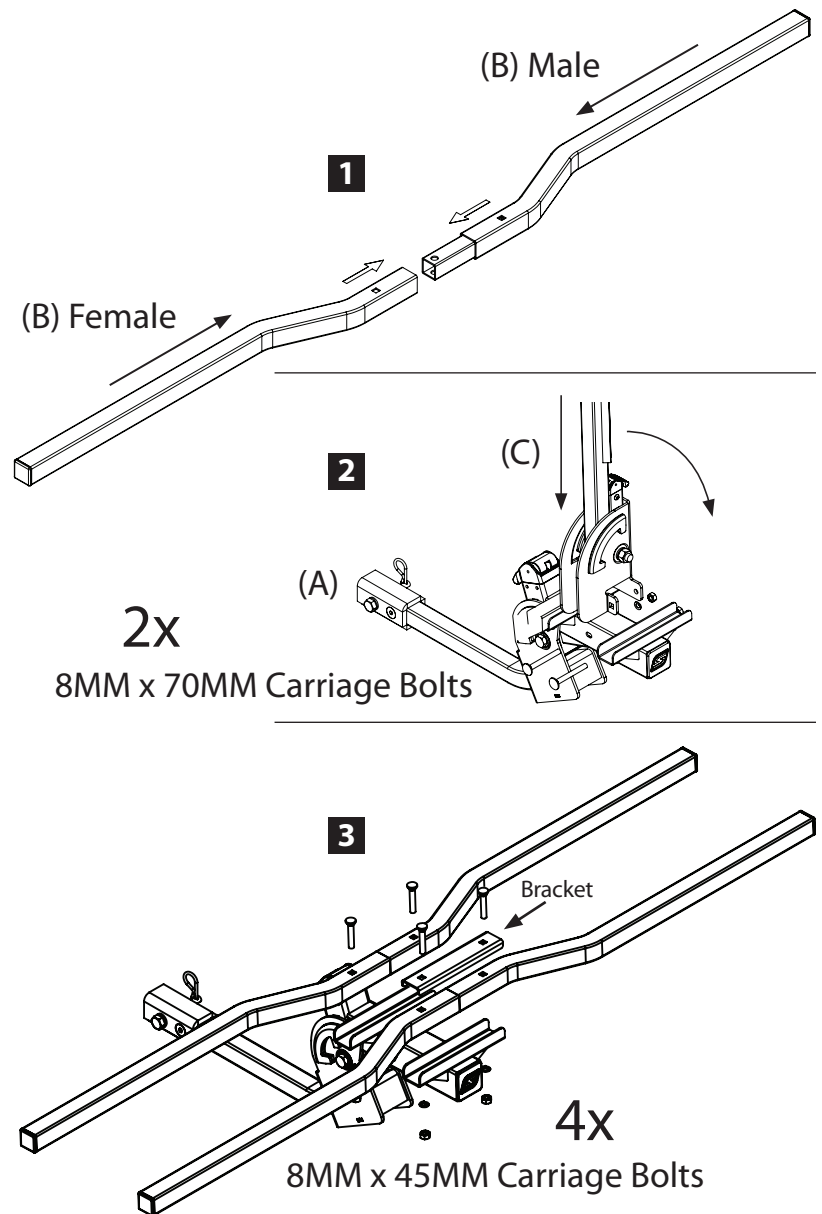
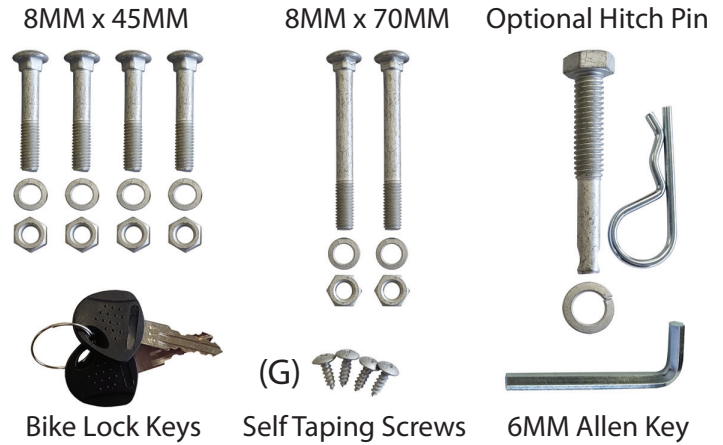

## Installing the Rack Into Your Vehicle:

1. Insert the bike rack into the 2" or 1-1/4" receiver. Install the 1/2" threaded locking hitch pin and tighten to 50 ft lbs. (very tight). Put on the lock head until it is securely attached. **NOTE:** A non-locking hitch pin and clip is supplied. Some vehicle hitches may not have room for the locking pin.

# INSTRUCTION SHEET

PRODUCT: 64678 Current ▪ Page 2 of 3



- The rack is designed to carry up to two 60 lbs. bikes. You cannot combine weight to carry one bike over 60 lbs. If installing an ebike you may have to remove the battery so the bike does not exceed 60 lbs.

## Bike Installation:

- Pull the lever on the bottom of the upright ratchet arm and fold down. This allows you to easily put the inside bike onto the rack. The taller bike should go on the inside location.
- Adjust the trays to the wheels of the bike so that they are all the way in the tray. Trays press on the insides of the tires. Once these are adjusted tighten the knobs on the tray so that they are secure and cannot slide. Attach the strap to secure the wheel into the wheel tray.
- Fold the upright bar back into the upright position. You should hear a click to indicate the cam is engaged.
- Push the longer hook down onto the bike. Press the release button on the hook to slide it more easily into place. Release the button when the hook is securely holding the bike. Releasing the button locks the hook in place and prevents it from any upward movement while in transit. Ensure the hook arm is fully locked into the notches on the upright ratchet arm. **IMPORTANT:** You should always ensure that the hook is located in the lowest position on the top tube. It is usually at the connection point of the top tube and the seat tube (diagram 7).
- Install the outside bike in the same manner using the short hook.
- After complete installation check all pins and tighten knobs to ensure they are all tight and that the bikes are motionless in the rack. **IMPORTANT:** You have to ensure that all of the wheel straps are attached and secure.
- To lock your bikes rotate the key in the ratchet hook so the button cannot be depressed (diagram 8). **NOTE:** Never leave your bikes unattended for any length of time. Locks are meant as a deterrent and won't prevent bike theft.

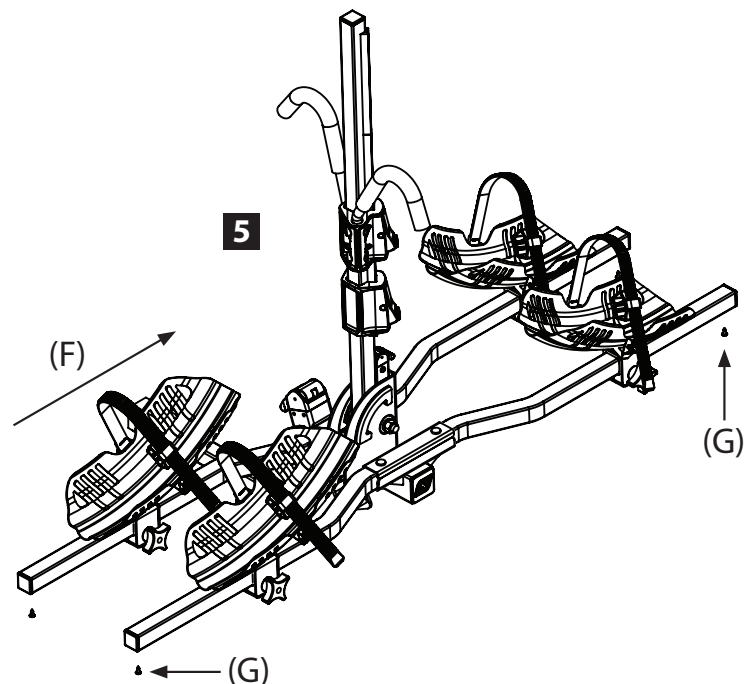
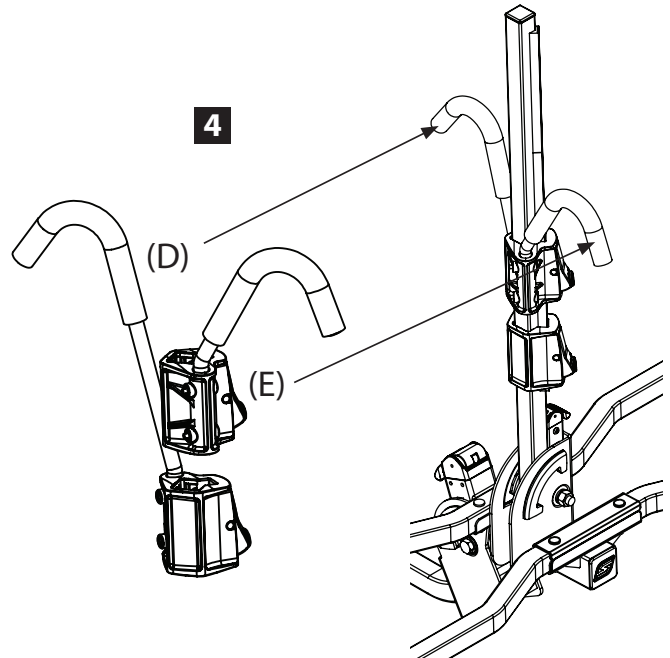

## ⚠ WARNING

Due to the increase in thinner/lighter "carbon frame bikes" this rack may be inappropriate because the hook clamps the frame. Please check with your bike manufacturer for specific details.

# INSTRUCTION SHEET

PRODUCT: 64678 Current ▪ Page 3 of 3



- When the rack is not in use the main ratchet arm can be folded down and the complete rack can be folded up against the vehicle. Ensure that the cam lever is completely engaged before driving.
- The rack can be tilted away from the vehicle by pulling the cam lever and lowering the rack and bikes. **NOTE:** Ensure you return the rack to the level position before driving. Move the rack up and down to ensure the cam lever is fully engaged.

## Important Notes:

- This bicycle rack has been designed to carry 1 or 2 bikes, 60 lbs. per bike. Do not install on a Class 1, 1-1/4" hitch.
- This rack is designed for typical use and applications (on paved or smooth gravel roads). Do not use this rack on a vehicle that will be driven on rough roads or where the rack (and bikes) will be subject to significant or constant jarring and/or shock, or any vehicle with very stiff springs that will transfer the load shock directly to the rack and bikes.
- Proper fitting and installation of this carrier to your specific vehicle is critical, and is not the manufacturer's responsibility.
- Improper use of this product may result in damage to your rack, your vehicle, your bicycles, or even other vehicles driving behind you (as a result of colliding with or trying to avoid fallen bicycles and/or the rack).
- The purchaser should be aware that the load created by a rack and bicycles can exceed the maximum rating on the hitch or bumper.
- Swagman Racks are powder coated to help prevent rust. When leaving them outside for extended periods of time the finish will lose its luster. It is recommended that when not in use it is stored indoors.
- Take care to add padding on any area of the bikes that touches another bike or any part of the vehicle. Damage can and will happen (to your bikes and/or to the vehicle) if care is not taken during the loading and transporting of your bikes, and padding used where necessary.
- Bicycle tires should be kept at least 6" away from the exhaust pipes of the vehicle. The high temperature exhaust exiting from the exhaust pipes is hot enough to melt or damage tires. The bike rack should also be kept away from the direct exhaust flow. Also check when the bike rack is folded up.
- Bikes fitted with large accessories (such as a child carrying seat) will greatly increase the wind resistance and therefore the pressure on the rack and all vehicle mounting points. Reducing vehicle speed will reduce the chance of any problems occurring because of this situation.
- After reading this manual, should you have any additional questions regarding the compatibility, fitting, and/or use of this rack, please call your nearest Swagman authorized retail dealer or Swagman Customer Service.

## ⚠ Mounting the bike rack on a Trailer or 5th Wheel:

Purchaser is advised that the load created by rack and bicycles will exceed the strength of trailer or 5th wheel bumper, mounting location or the bike rack. The rack is not under warranty if mounted in this location.

