

**INSTRUCTIONS:**

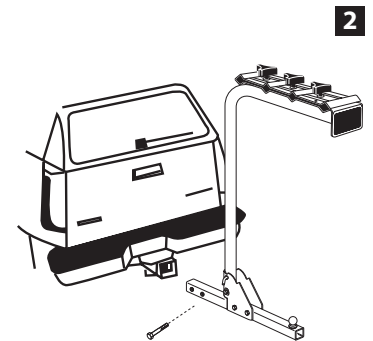

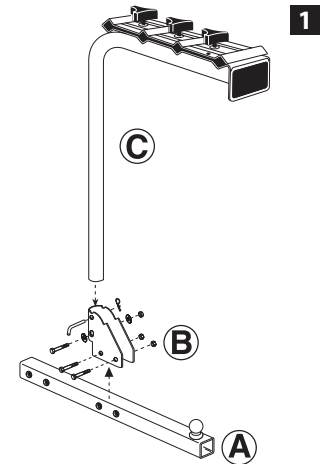

1. Assembling the 4 Bike Rack (diagram 1).
    - a. Slide rack 'C' into collar 'B'. Secure in place with 12mm x 80mm bolt, nylon washers and lock nut.
 

**NOTE:** The nylon washers are on each side of part B. This product protects the powder coat from erosion.
    - b. Torque the nut using a 18mm wrench. It should be tight enough to allow for movement of the rack in the collar to fold down as required. **NOTE:** The locknuts are a special machine nut, they require force to tighten.
    - c. Periodically check to make sure that the bolt and lock nut are secure.
    - d. Place a 1/2" Pin and clip through the top hole.
    - e. Slide the receiver piece 'A' into collar 'B'. Secure in place with two 12mm x 80mm bolts and lock nuts.
    - f. Torque the nuts on tightly using a 18mm wrench (60 ft/lbs).
    - g. Periodically check to make sure that the bolts and lock nuts are secure.
  2. Place your rack receiver into your receiver hitch (diagram 2).
  3. Fit rack as close to the vehicle as possible.
  4. Secure your rack with the hitch pin and clip.
  5. Check to ensure rack is secure and safety pin is in place.
  6. To remove top plate, undo captured knobs on your rack. Remove top plate. Place bike top tubes in vinyl grooves so that they are balanced as shown in diagram 3. (Sloping top tube bikes may sit on an angle).
  7. After placing a maximum of 4 bikes on your rack, replace top plate and tighten knobs evenly.
- NOTE:** The tow ball should be a 3000 lb ball with a 3/4" shaft. It should be tightened to 75lbs torque.

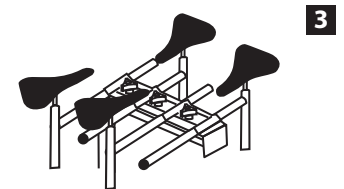
**IMPORTANT NOTES:**

- This bicycle rack has been designed to carry 1, 2, 3, or 4 bikes.
- This rack is designed for typical use and applications (on paved or smooth gravel roads). Do not use this rack on a vehicle that will be driven on rough roads or where the rack (and bikes) will be subjected to significant or constant jarring and/or shock, or any vehicle with very stiff springs that will transfer the load shocks directly to the rack and the bikes.
- Proper fitting and installation of this carrier to your specific vehicle is critical, and is the owners sole responsibility.
- Improper use of this product may result in damage to your rack, your vehicle, your bicycles, or even other vehicles driving behind you (as a result of colliding with or trying to avoid fallen bicycles and/or the rack).
- The purchaser should be aware that the load created by a rack and bicycles can exceed the maximum rating on the hitch or bumper.
- Swagman racks are powder coated to help prevent rust. When leaving them outside for extended periods of time the finish will lose its luster. It is recommended that when not in use the rack is stored indoors.
- The rack won't carry bikes with oblong frame tubes or unusually large frame sizes.
- Take care to add padding on any area of the bikes that touches another bike or any part of the vehicle. Damage can and will happen (to your bikes and/or to the vehicle) if care is not taken during the loading and transporting of your bikes, and padding used where necessary.

**Bike Mounting Options**

-  Single Bike
  -  Two Bikes
  -  Three Bikes
  -  Four Bikes
- Oversized Tube  
● Standard Tube

**IMPORTANT NOTES (Continued):**

- Bicycle tires should be kept at least 6" away from the exhaust pipes of the vehicle. The high temperature exhaust exiting from the exhaust pipes is hot enough to melt or damage tires. Keep all bike tires totally away from the direct exhaust flow.
- Bikes fitted with large accessories (such as child carrying seat) will greatly increase the wind resistance and therefore the pressure on the rack and all vehicle mounting points. Reducing vehicle speed will reduce the chance of any problems occurring because of this situation.

** Mounting the Bike Rack on a trailer or 5th wheel:**

1. Purchaser is advised that the load created by rack and bicycles may exceed the strength of the trailer or fifth wheel bumper, mounting location or the bike rack.
2. The rack is not covered under warranty if mounted on the back of a trailer or fifth wheel.