

SUPERWINCH®

TECHNICAL INSTALLATION MANUAL

WINCH2GO 4000™ WINCH2GO 4000SR™

4,000 lb (1814 Kg) 12 Volt DC Electric Winch



CAUTION

READ AND UNDERSTAND THIS GUIDE BEFORE INSTALLATION AND OPERATION.



Throughout this manual you will find notations with the following headings:

- DANGER** Indicates an imminently hazardous situation which, if not avoided will result in death or serious injury.
- WARNING** Indicates a potentially hazardous situation which, if not avoided could result in death or serious injury.
- CAUTION** Indicates a potentially hazardous situation or unsafe practice, which if not avoided could result in injury.
- NOTICE** Indicates an unsafe practice, which if not avoided, could result in property damage.

The following symbols on the product and in the owners manual are used:



Read the Owners Manual.

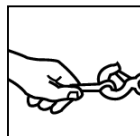

Always use a Hand Saver.

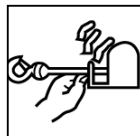

Keep clear of Winch Wire Rope and Hook while operating.

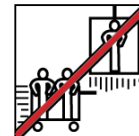

Never use Winch to Lift or Move People.



Never use Winch to Hold Load in Place.

Read the Winch Users Guide for additional safety symbols

Your winch is a very powerful machine. If used unsafely or improperly there is a possibility that property damage or personal injury could result.

Note: all safety references in this manual that refer to use of, ROPE, also apply to the use of, both, SYNTHETIC and WIRE ROPE.

⚠ WARNING The responsibility for safe installation and operation of the winch and prevention of personal injury and property damage ultimately rests with you, the operator. There is no substitute for the use of good judgement and caution in operating a winch.

⚠ WARNING The rope may break before the winch stalls. For heavy loads, use a pulley block to reduce the load on the rope.

1. Maximum working load capacity is on the rope layer closest to the drum. **DO NOT OVER LOAD. DO NOT ATTEMPT PROLONGED PULLS AT HEAVY LOADS.** Overloads can damage the winch and/or the rope and create unsafe operating conditions. **FOR LOADS OVER 1,000 lbs (454 kg), WE RECOMMEND THE USE OF THE OPTIONAL PULLEY BLOCK TO DOUBLE LINE THE ROPE.** This reduces the load on the winch and the strain on the rope by approximately 50%. Attach hook to load bearing part. The vehicle engine should be running during winch operation. If considerable winching is performed with the engine off, the battery may be too weak to restart the engine. See **Figure 1**.

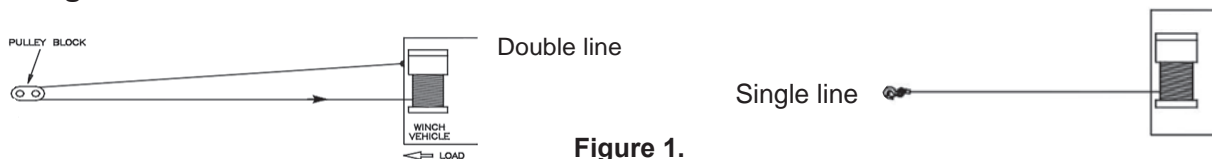

Figure 1.

2. **AFTER READING AND UNDERSTANDING THIS MANUAL, LEARN TO USE YOUR WINCH.** After installing the winch, practice using it so you will be familiar with it when the need arises.



3. **NEVER “move” your vehicle to assist the winch in pulling the load.** The combination of the winch and vehicle pulling together could overload the wire rope and the winch.

4. **ALWAYS STAND CLEAR OF THE WIRE ROPE, HOOK AND WINCH. IN THE UNLIKELY EVENT OF ANY COMPONENT FAILURE IT'S BEST TO BE OUT OF HARM'S WAY.**

5. **INSPECT ROPE AND EQUIPMENT FREQUENTLY. A FRAYED ROPE WITH BROKEN STRANDS SHOULD BE REPLACED IMMEDIATELY.** Always replace rope with the manufacture's identical replacement part (see Replacement Parts List). Periodically check the winch installation to ensure that all bolts are tight.

6. **ALWAYS USE HEAVY LEATHER GLOVES when handling rope. DO NOT LET ROPE SLIDE THROUGH YOUR HANDS.**



7. **NEVER WINCH WITH LESS THAN 5 TURNS OF WIRE, 8 TURNS OF SYNTHETIC ROPE AROUND THE WINCH DRUM** since the rope end fastener may NOT withstand full load.

8. KEEP CLEAR OF WINCH, TAUT ROPE AND HOOK WHEN OPERATING WINCH. Never put your finger through the hook. If your finger should become trapped in the hook, you could lose your finger. ALWAYS USE THE HANDSAVER when guiding the wire rope in or out. See **Figure 2**.

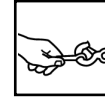

9. NEVER HOOK THE ROPE BACK ONTO ITSELF because you could damage the rope. Use a nylon sling, See **Figure 3**



10. It is a good idea to lay a heavy blanket or jacket over the wire rope near the hook end pulling heavy loads. If a rope failure should occur, the cloth will act as a dampener and help prevent the rope from whipping. See **Figure 4**.



We recommend the Superwinch®
Rope Dampener p/n 2570

11. NEVER USE YOUR WINCH FOR LIFTING OR MOVING PEOPLE.

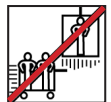

12. Your winch is not intended for overhead hoisting operations



13. AVOID CONTINUOUS PULLS FROM EXTREME ANGLES as this will cause the rope to pile up on one end of the drum. This can jam the rope in the winch, causing damage to the rope or the winch. See **Figure 5**.

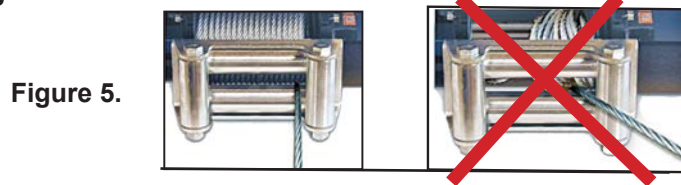

14. NEVER OBSCURE THE WARNING INSTRUCTION LABELS.

15. Always operate winch with an unobstructed view of the winching operation.

16. Equipment such as tackle, hooks, pulley blocks, straps, etc, should be sized to the winching task and should be periodically inspected for damage that could reduce their strength.

17. NEVER RELEASE FREESPOOL CLUTCH WHEN THERE IS A LOAD ON THE WINCH.

18. NEVER WORK ON OR AROUND THE WINCH DRUM WHEN WINCH IS UNDER LOAD.



19. NEVER OPERATE WINCH WHEN UNDER THE INFLUENCE OF DRUGS, ALCOHOL OR MEDICATION.

20. ALWAYS DISCONNECT WINCH POWER LEADS TO BATTERY BEFORE WORKING IN OR AROUND THE WINCH DRUM so that the winch cannot be turned on accidentally.

21. When moving a load, slowly take up the rope slack until it becomes taut. Stop, recheck all winching connections. Be sure the hook is properly seated. If a nylon strap is used, check the attachment to the load.

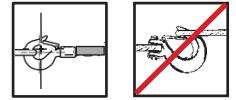

22. When using your winch to move a load, if a vehicle is to be used as an anchor point place the vehicle transmission in neutral, set vehicle brake, and chock all wheels.

23. NEVER USE THE WINCH TO HOLD LOADS IN PLACE. Use other means of securing loads such as tie down straps.



24. ALWAYS USE ONLY FACTORY APPROVED SWITCHES, REMOTE CONTROLS AND ACCESSORIES. Use of non-Superwinch® approved components may cause injury or property damage and could void your warranty.

25. NEVER MACHINE OR WELD ANY PARTS OF THE WINCH. Such alterations may weaken the structural integrity of the winch and will void your warranty.

26. NEVER CONNECT WINCH TO EITHER 110V AC HOUSE CURRENT OR 220V AC MAINS AS WINCH BURNOUT OR FATAL SHOCK MAY OCCUR.



27. NEVER allow shock loads to be applied to winch or rope.

28. ALWAYS USE caution when pulling or lowering a load up or down a ramp or incline. Keep people, pets and property clear of the path of the load.

29. NEVER USE handle on outside of box as a winching anchor.

30. NEVER hold onto the box handles when winching.

INSTALLATION



Correct installation of your winch is required for proper operation.

▲ WARNING Do not substitute any strength grade weaker than ISO grade 8.8

▲ WARNING Be sure that both the mounting plate and winch hardware have been properly tightened.

▲ CAUTION No part of the vehicle (skid plates, wiring, auxiliary light, tires, etc.) should impede the operation of your Superwinch®. When mounting, check all vehicle and winch parts free of obstructions. Be sure that the winch mounting location does not significantly reduce ground clearance.

▲ WARNING This winch MUST be mounted with the wire rope in the underwind direction. Improper mounting could damage your winch and void your warranty.



WINCH2GO™ can be used in a portable fashion by using the supplied straps and shackles.

Route the rear strap around a tree or secure anchor point, and secure the two loops to the two rear shackles on the WINCH2GO™ baseplate. ALWAYS be sure that straps do not contact sharp edges or hot surfaces. See **Figure 6**.

Figure 6.

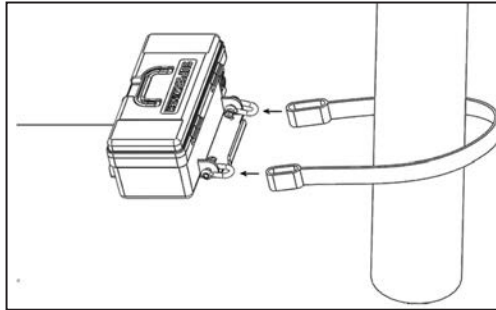

Freespool the hook and winch rope out to the load and secure using the second supplied strap. ALWAYS be sure that the hook latch closes around the loop straps. Latch closed with strap loops inserted in the hook. See **Figure 7**.

Figure 7.



The winch Users Guide, that accompanies this Technical Installation Manual provides additional information on rigging techniques and safety precautions.

ALWAYS watch for pinch points and keep all hands away from the winch during operation.



When taking up the slack in the rope, be observant of the, WINCH2GO™ unit and watch for binding or obstructions as the, WINCH2GO™ may move while the slack is removed from the rigging, and during winching.

During use, avoid long durations of winching. Stop winching and check the motor for heat. This is done through the slot opening inside the unit, providing access to the motor.

NOTE: MOTOR MAY BE HOT. If the winch motor is hot, allow the winch to cool before continued winching. See **Figure 8**.

Figure 8.

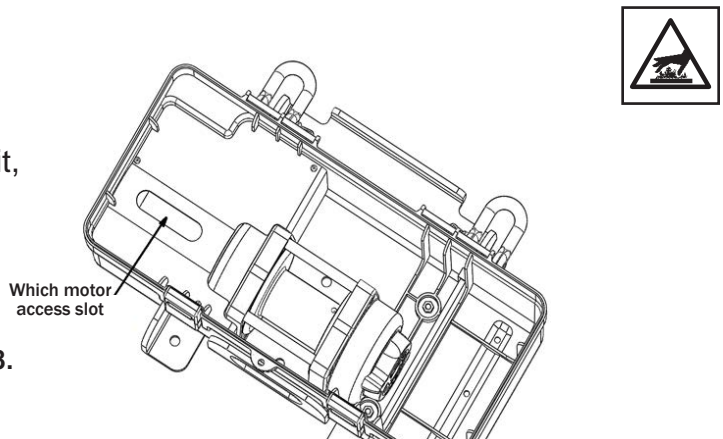

The Pulley Block is recommended for heavy loads. Run the rope through the Pulley Block, and connect the hook back to the unit using the shackle and front shackle hole on the baseplate. See **Figure 9**.

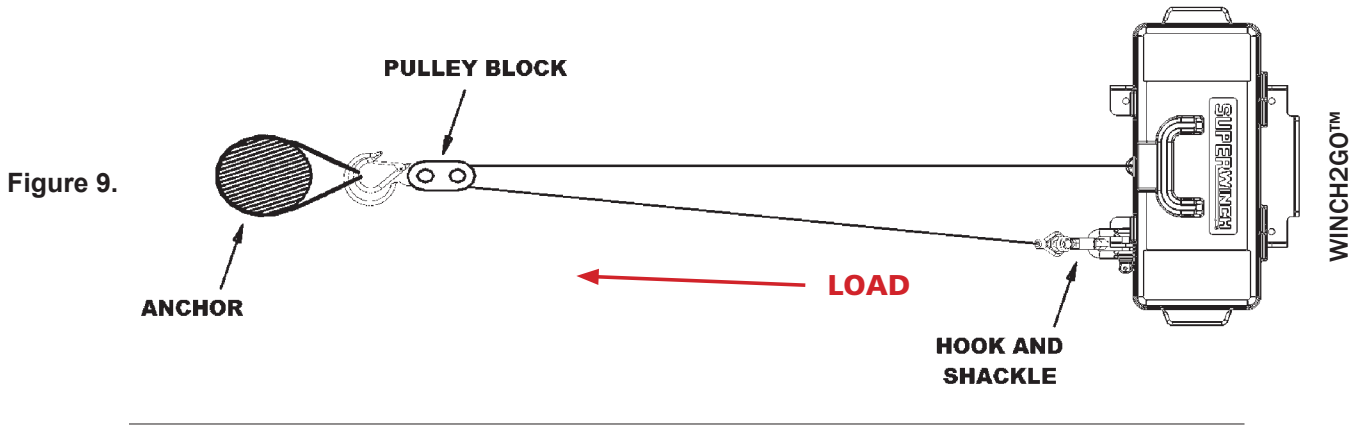

Do not use “choke” rigging on strap

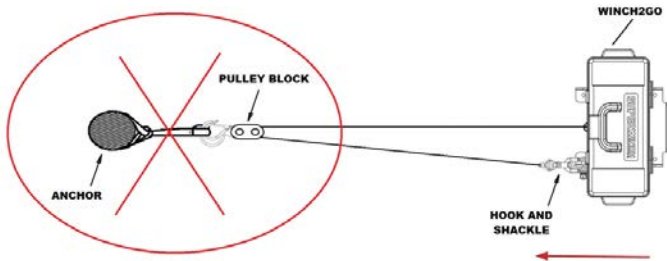

Do not use strap in single rigging when winch is doubled lined with pulley block.

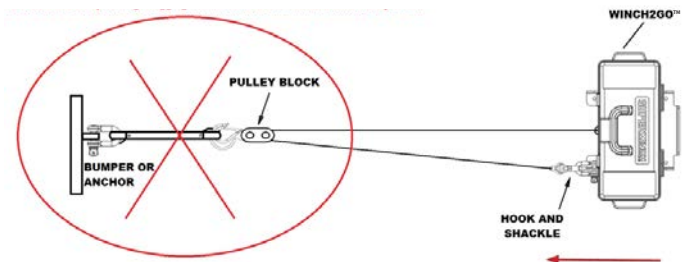

PERMANENT MOUNTED USE



The preferred mounting arrangement is to use the four (4) outer bolt holes in the mounting plate to mount the unit to a surface. To resist the winching loads a minimum of 1/4” (6mm) mounting plate thickness should be used. Be certain that the structure used for mounting will resist the winching loads of the WINCH2GO™. When using the four (4) bolt mounting arrangement, the winch’s wire rope may be secured back to the front shackle for double-lining. See **Figure 10a and 10b**.

Figure 10a.

Using the supplied M10 mounting bolts, washers, and nuts, tighten the mounting hardware to 32 ft-lb (43 N-m).

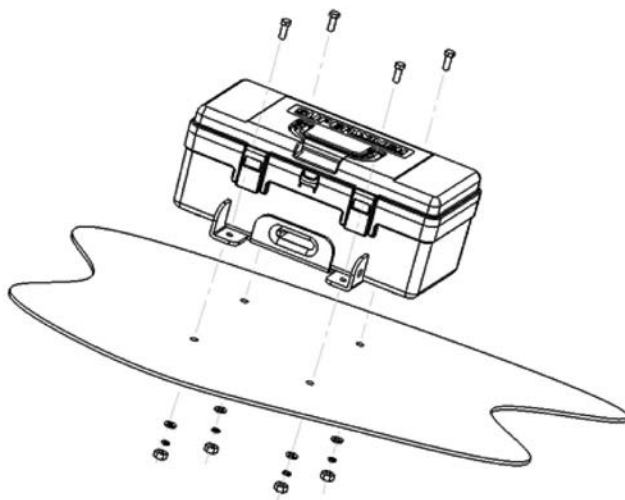
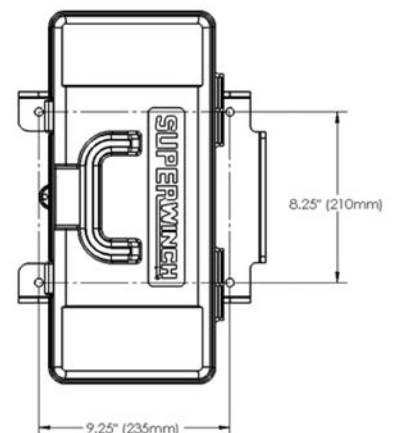

Figure 10b.

WINCH2GO™
4 - Hole Mounting
Pattern dimensions



An optional mounting arrangement is to use the two (2) internal bolt holes with the stiffening plate.

For this option, place the winch Freespool in Disengaged, and spool off enough rope from the winch drum to insert the steel stiffening plate underneath the winch drum, if it was not Inserted during winch assembly. To resist the winching loads a minimum of 1/4" (6mm) mounting plate thickness should be used. Be certain that the structure used for mounting will resist the winching loads of the WINCH2GO™. Once mounting and wiring is complete, the winch rope may be powered back onto the drum. See **Figure 11a. and 11b.**

⚠ WARNING WHEN USING THE 2 BOLT MOUNTING OPTION, DO NOT USE THE FRONT SHACKLE HOLE TO DOUBLE-LINE THE PULL BACK TO THE WINCH BASEPLATE. IF DOUBLE-LINING WITH THE PULLEY BLOCK, ALWAYS SECURE THE WINCH HOOK TO A NEARBY STRUCTURE, AND NOT THE WINCH BASEPLATE.

Figure 11a.

*WINCH2GO™
2-Hole Mounting
Pattern dimensions*

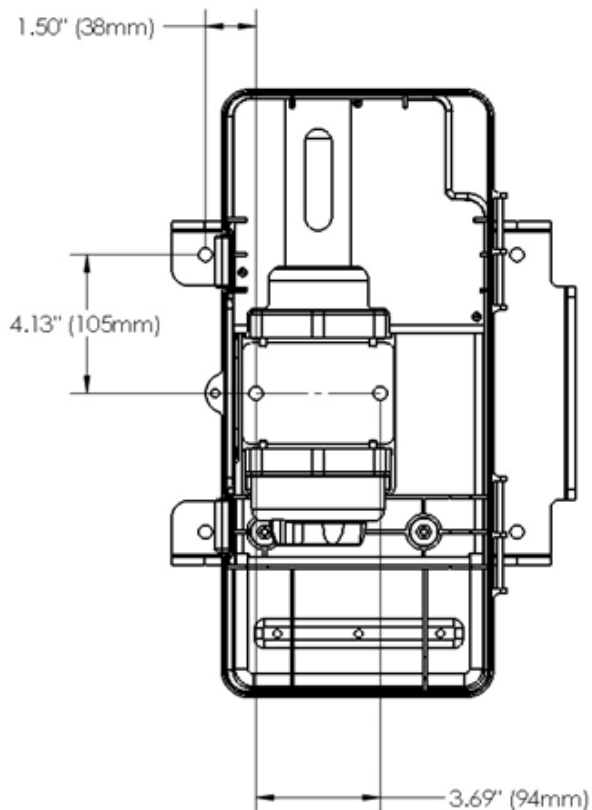
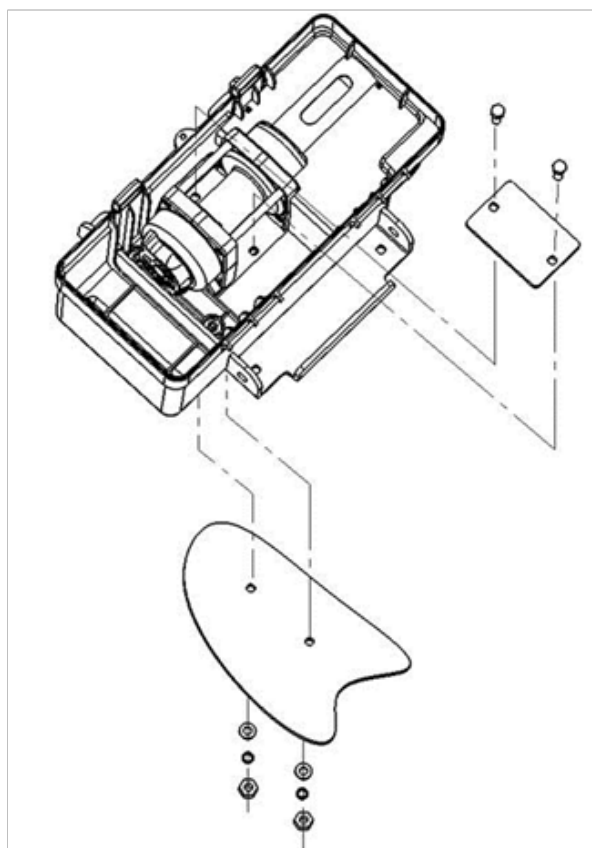

Figure 11b.

Using the supplied M10 mounting bolts, washers, and nuts, tighten the mounting hardware to 32 ft-lb (43 N-m).



WINCH2GO™ comes fully pre-wired internally.

⚠ WARNING The location of the Switch **MUST NOT** Interfere with safe operation of the vehicle and winch. Wiring **MUST NOT** come in contact with any moving parts or sharp edges, such as engine, winch drum, wire rope, straps, suspension, brakes, exhaust or steering.

Connect the Battery Cables from the WINCH2GO™ to the battery and plug in the handheld controller. See Figure 12.

ALWAYS be sure that power and controller cables do not interfere with the winching operation or tangle the winch operator. **ALWAYS** keep safety at top priority.

Figure 12.

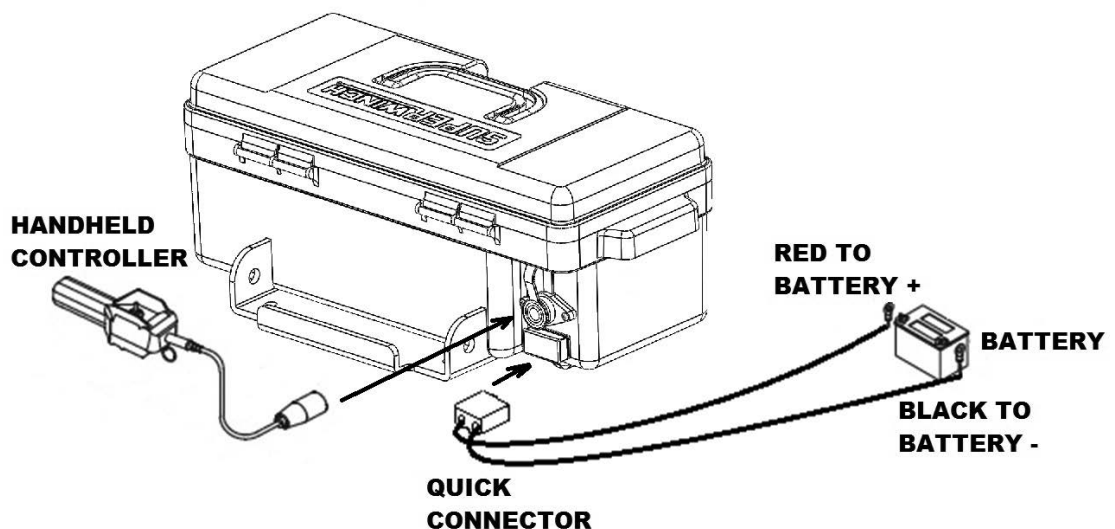

Apply several layers of electrical tape where wiring may come into contact with sharp metal parts of the vehicle to prevent insulation abrasion or cutting.

⚠ WARNING Automotive batteries contain gasses which are flammable and explosive. Wear eye protection during installation and remove all metal jewelry. Do not lean over battery while making connections.

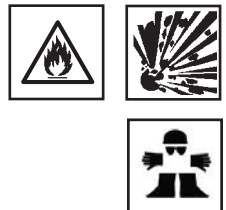

WIRING TEST OPERATION

To test that the unit is wired properly at the battery, perform the following operation:

Turn the freespool knob to “Disengaged” position as shown in **Figure 13** (page 9) Pull several feet of rope off the drum. Return the freespool knob back to the “Engaged” position. Activate the winch in “Cable Out” momentarily to check drum rotation direction. If the drum rotates in the wrong direction, re-check your wiring.

Freespool must be fully engaged before winching. See Figure 14. Never engage Freespool knob while drum is turning.

Turn the freespool knob to the, “Disengaged” position as shown in **Figure 13**. If there is a load on the rope, the freespool knob may not pull out easily. **DO NOT FORCE THE FREESPOOL KNOB.** Release tension on the freespool by jogging out some of the rope. Release the freespool and pull out the rope and secure to the anchor or load. Check that there are at least five (5) turns of rope left on the drum. Re-rig the drum by returning the Freespool knob to the “Engaged” position. See **Figure 14**.

Figure 13.
(DISENGAGED, Freespool position)



Correct underwind operation



Figure 14.
(ENGAGED position)



MAINTENANCE - ROPE REPLACEMENT

Winch rope, either Wire or Synthetic, is a wear item in your WINCH2GO™. Any frayed, kinked, or visibly damaged rope must be replaced immediately.

- When replacing your rope, or any other component on your WINCH2GO™, always use only Superwinch® recommended replacement parts. Use of any other replacement parts is not recommended and will void your warranty.
- To replace your rope, first completely remove the old rope. For Wire Rope, this is done by loosening the drum setscrew holding the rope in the drum hole, and unwrapping all of the rope from the drum. Wear thick leather work gloves to protect your hands. For Synthetic Rope, unwrap all of the rope from the drum, and remove the taped section and remove the rope from the drum hole.
- Once the old rope is removed, review the winch drum, the hawse area, and baseplate for damage, sharp edges, or any other conditions that may damage the new rope. Replace any worn or damaged components.
- Unwrap and unroll your new rope. Feed the new rope through the hawse opening in the baseplate, and under the winch drum. Pull the rope up behind the drum, and insert the rope into the rope hole in the winch drum.
- For Wire Rope, tighten the setscrew securely. For Synthetic Rope, the rope is fed through the hole, the free end is then positioned along the drum, and taped to the drum. The rope is then tightly wound onto the drum.

Insert through the hole and fasten with set screw or plug



PERFORMANCE



Max. Pulling Capacity	LOAD		SPEED		CURRENT DRAW
	lbs	kg	ft/min	m/m	*12VDC Motor Current, Amps
4,000 lbs (1814 kg)	0	0	20.0	6.0	20
	1,000	453	15.5	4.7	75
	2,000	907	12.0	3.6	110
	3,000	1360	9.0	2.7	160
	4,000	1814	5.5	1.6	220

* Performance based on first layer of rope wrapped on the drum

INTERMITTENT DUTY

⚠ WARNING If the motor stalls, do not continue to apply power. If the end of the motor becomes hot, stop winching and allow the motor to cool. Do not touch the hot motor.

An electric winch is like any other motor driven power tool such as an electric drill or saw. The electric motor should not be allowed to become excessively hot. Normal precautions will extend the life of your motor. Keep the durations of pulls as short as possible.

The Winch Users Guide that accompanies this Technical Installation Guide provides information on intermittent duty.

INSPECTION and STORAGE

After use, repack the items neatly into the WINCH2GO™. Check all straps, shackles, pulley block, and the power cord and controller cord for damage. ALWAYS review ALL components after winching, and before the next winching operation. NEVER operate a winch with damaged components, and ALWAYS use genuine Superwinch® replacement parts to ensure safety. Use of parts other than genuine Superwinch® replacement parts can be unsafe and will void your warranty.



SPECIFICATIONS for WINCH2GO, 12 VDC and OUTSIDE DIMENSIONS

Working Load: 4,000 lbs (1814 kg) single line 8,000 lbs (3628 kg) with pulley block

Motor: 1.4 hp (1.0 kW) 12 VOLT DC

Gear Ratio: 166:1

Freespool Clutch: Cam Action Knob

Drum Barrel Diameter: 2.0" (50.8 mm)

Drum Length: 3.03" (77.0 mm)

Wire Rope: 3/16" X 50' (4.8 mm X 19.0 m)

Synthetic Rope: 3/16" X 50' (4.8 mm X 19.0 m)

Installed WINCH2GO™ Weight with

Wire Rope: 43 lbs (19.5 kg)

Installed WINCH2GO™ Weight with

Synthetic Rope: 41 lbs (18.6 kg)

Switching Method: Sealed Handheld Rocker Switch

Fairlead: Hawse fairlead in baseplate

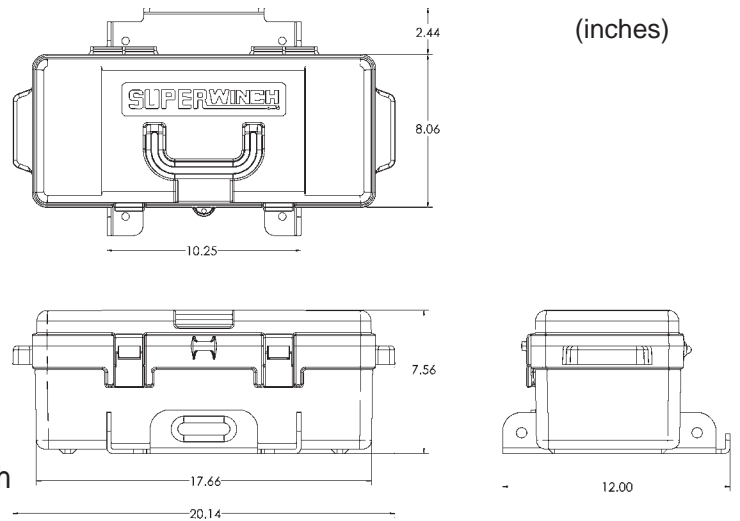

REPLACEMENT PARTS

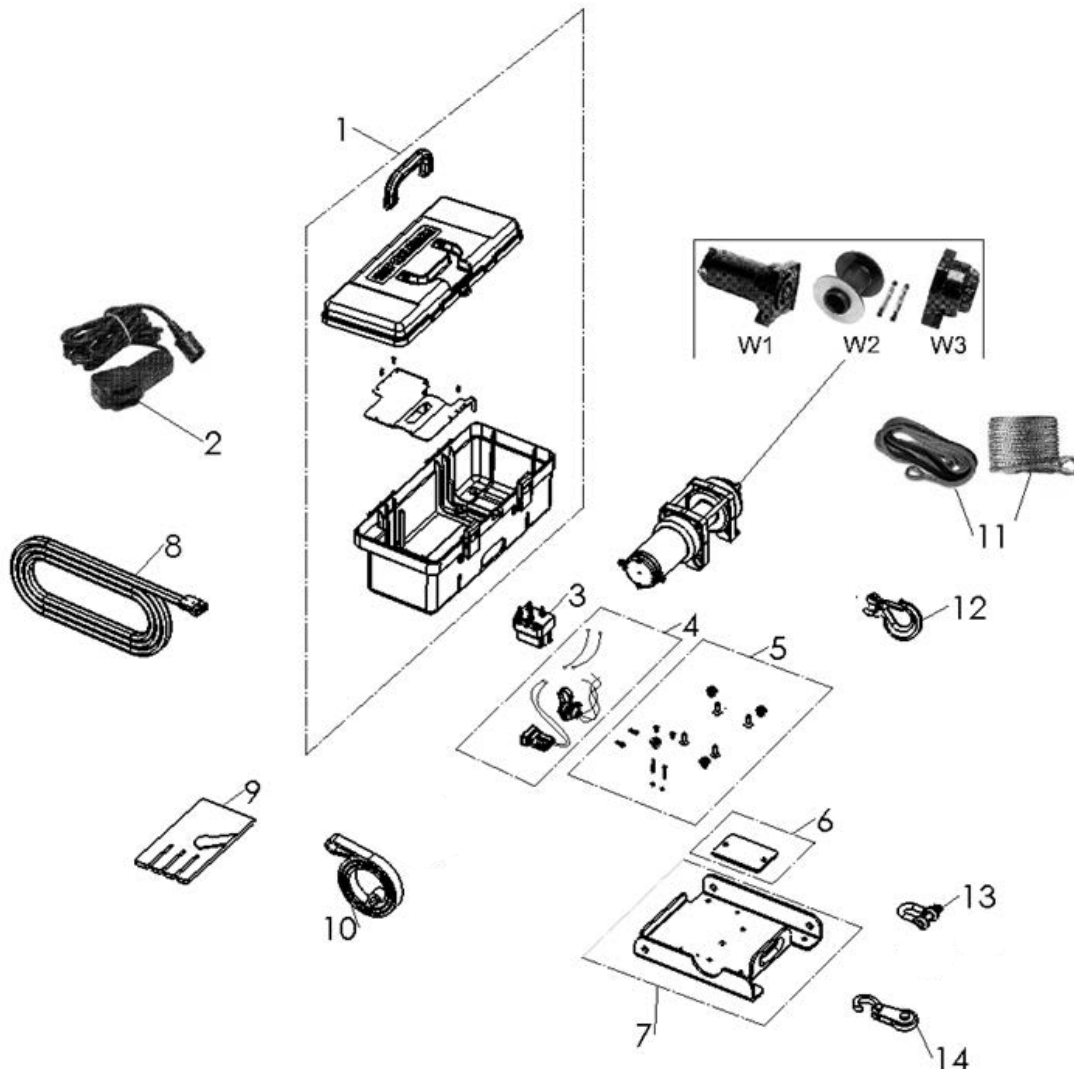

REPLACEMENT PARTS LIST



Reference No.	Description	Part Number
1	BOX-WITH LID AND WIRING GUARD	87-42685
2	HANDHELD CONTROLLER	87-12895
3	SOLENOID	87-12893
4	WIRING KIT – INTERNAL	87-30170
5	HARDWARE KIT – COMPLETE	87-14538
6	MOUNT STIFFENING PLATE	87-24649
7	MAIN MOUNTING PLATE	87-42686
8	POWER CORD	87-24643
9	GLOVES	90-22611
10	STRAP – SINGLE	87-24644
11	WIRE ROPE (IF FITTED) SYNTHETIC ROPE (IF FITTED)	1511F 87-24076
12	HOOK	87-42615
13	D-SHACKLE – SINGLE	87-17394
14	PULLEY BLOCK	87-30171
W1	WINCH MOTOR ASSEMBLY	87-24078
W2	WINCH STEEL DRUM AND TIE BARS	87-24075
W3	WINCH GEARBOX ASSY	87-24079

TROUBLESHOOTING CHART



“If a problem arises please contact your nearest Superwinch® dealer or repair shop.”

Symptoms	Possible Cause(s)	Corrective Actions
Motor will not operate or runs in one direction only	<ol style="list-style-type: none"> 1. Bad connections or broken wires. Most often, winch problems can be traced to loose connections, corrosion, or broken wires. 2. Damaged or stuck solenoid. This is most likely caused by not holding the inner nut to keep the stud from turning when attaching wire to solenoid. 3. Handheld switch inoperative. 4. Damaged motor. 5. Solenoid is not grounded. 6. Weak or dead battery. 	<ol style="list-style-type: none"> 1. Check all wiring. Look for loose connections, corrosion, and broken or damaged wires. Any wires that appear damaged must be replaced. Check handheld controller for damaged wiring or damaged or corroded plug and socket connections. CAUTION: Always use two wrenches (spanners) when loosening or tightening motor and solenoid connections. (See Figure.16) Otherwise motor or solenoid damage can occur. 2. CAUTION: <u>Disengage freespool before performing this test to prevent powering the winch drum.</u> If a solenoid sticks once, it is likely to stick again and must be replaced immediately. Tap solenoid to free stuck contacts. For individual single-coil solenoids, check by applying voltage to the small solenoid terminal. Be sure solenoid is grounded back to battery. For multiple-coil block-style solenoids, disconnect existing connections, ground center terminal, and apply voltage to outer terminals one at a time. A solenoid that is not stuck will make an audible “click” when first energized. 3. Replace switch. 4. Replace or repair motor. Review brushes. Brushes may be sticking or worn. Brush kits are available for some models. 5. Check ground path between battery negative and solenoid. 6. Recharge or replace battery. Check charging system.
Winch will not shut off	<ol style="list-style-type: none"> 1. Solenoid stuck “on”. 	<ol style="list-style-type: none"> 1. If solenoid sticks on, reverse direction and hold trigger switch on until the power lead can be disconnected. A safety on-off switch is available as an accessory.
Motor runs extremely hot	<ol style="list-style-type: none"> 1. Long period of operation. 2. Damaged motor. 3. Damaged brake. 	<ol style="list-style-type: none"> 1. Allow to cool. 2. Replace or repair motor. 3. Replace or repair brake.
Motor runs but with insufficient power or line speed	<ol style="list-style-type: none"> 1. Weak battery. 2. Battery to winch wire too long. 3. Poor battery connection. 4. Poor ground. 5. Damaged brake. 	<ol style="list-style-type: none"> 1. Recharge or replace battery. Check charging system. 2. Use larger gauge wire. 3. Check battery terminals for corrosion. Clean as required. 4. Check and clean connections. 5. Repair or replace brake.
Motor runs but drum does not turn	<ol style="list-style-type: none"> 1. Freespool not engaged. 	<ol style="list-style-type: none"> 1. Engage Freespool.
Winch runs backwards	<ol style="list-style-type: none"> 1. Motor wires reversed. 2. Solenoid wired incorrectly. 	<ol style="list-style-type: none"> 1. Recheck wiring. 2. Recheck wiring.
Will not hold load	<ol style="list-style-type: none"> 1. Excessive load. 2. Worn or damaged brake. 	<ol style="list-style-type: none"> 1. Reduce load or double line. 2. Repair or replace brake.

Figure 16.

