

SUPERWINCH®

OWNER'S GUIDE

LP8500 lb 3856 kg
12 Volt DC [Electric Winch](#)

▲ CAUTION

READ AND UNDERSTAND THIS GUIDE BEFORE
INSTALLATION AND OPERATION.

Throughout this manual, you will find notations with the following headings:

▲ DANGER

Indicates an imminently hazardous situation which, if not avoided, will result in death or serious injury.

▲ WARNING

Indicates a potentially hazardous situation which, if not avoided, could result in death or serious injury.

▲ CAUTION

Indicates a potentially hazardous situation which, if not avoided, may result in minor or moderate injury. This notation is also used to alert against unsafe practices.

The following symbols on the product and in the Owner's manual are used:



Read Owner's Manual



Always Use Handsaw



Keep clear of winch, wire rope and hook while operating



Never use winch to lift or move people



Never use winch to hold loads in place

Note: Indicates additional information in the installation and operation procedures of your winch.

Correct installation of your winch is a requirement for proper operation.

Please Note: Winch is designed primarily for intermittent applications. This winch is not designed to be used in industrial or hoisting applications and Superwinch does not warrant it to be suitable for such use.

90-17439 Rev - 8/11/09

GENERAL SAFETY INFORMATION

Your winch is a very powerful machine. If used unsafely or improperly, there is a possibility that property damage or personal injury could result.

▲ WARNING The responsibility for safe installation and operation of the winch and prevention of personal injury and property damage ultimately rests with you, the operator. There is no substitute for the use of good judgement and caution in operating a winch.

▲ WARNING The wire rope may break before the winch stalls. For heavy loads, use a pulley block to reduce the load on the wire rope.

1. Maximum working load capacity is on the wire rope layer closest to the drum. **DO NOT OVERLOAD. DO NOT ATTEMPT PROLONGED PULLS AT HEAVY LOADS.** Overloads can damage the winch and/or the wire rope and create unsafe operating conditions. **FOR LOADS OVER 1/2 RATED CAPACITY, WE RECOMMEND THE USE OF THE OPTIONAL PULLEY BLOCK TO DOUBLE LINE THE WIRE ROPE (Figure 2).** This reduces the load on the winch and the strain on the wire rope by approximately 50%. Attach hook to load bearing part. The vehicle engine should be running during winch operation. If considerable winching is performed with the engine off, the battery may be too weak to restart the engine.

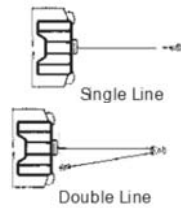





Figure 2

2. **AFTER READING AND UNDERSTANDING THIS MANUAL, LEARN TO USE YOUR WINCH.** After installing the winch, practice using it so you will be familiar with it when the need arises. 
3. **DO NOT "move" your vehicle to assist the winch in pulling the load.** The combination of the winch and vehicle pulling together could overload the wire rope and the winch.
4. **ALWAYS STAND CLEAR OF WIRE ROPE, HOOK AND WINCH. IN THE UNLIKELY EVENT OF ANY COMPONENT FAILURE IT'S BEST TO BE OUT OF HARM'S WAY.**
5. **INSPECT WIRE ROPE AND EQUIPMENT FREQUENTLY. A FRAYED WIRE ROPE WITH BROKEN STRANDS SHOULD BE REPLACED IMMEDIATELY.** Always replace wire rope with the manufacturer's identical replacement part (see Replacement Parts List). Periodically check the winch installation to ensure that all bolts are tight.
6. **USE HEAVY LEATHER GLOVES when handling wire rope. DO NOT LET WIRE ROPE SLIDE THROUGH YOUR HANDS.**
7. **NEVER WINCH WITH LESS THAN 5 TURNS of wire rope AROUND THE WINCH DRUM** since the wire rope end fastener may NOT withstand full load.

8. **KEEP CLEAR OF WINCH, TAUT WIRE ROPE AND HOOK WHEN OPERATING WINCH.** Never put your finger through the hook. If your finger should become trapped in the hook, you could lose your finger. 
ALWAYS USE THE HANDSAVER when guiding the wire rope in or out (See Figure 3). 

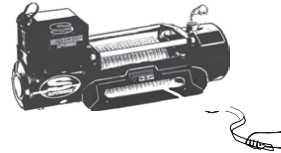

Figure 3

9. **NEVER HOOK THE WIRE ROPE BACK ONTO ITSELF** because you could damage the wire rope. Use a nylon sling (Figure 4).

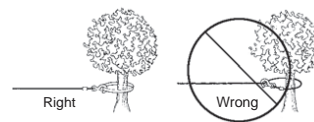

Figure 4

10. It is a good idea to lay a heavy blanket or jacket over the wire rope near the hook end when pulling heavy loads (Figure 5). If a wire rope failure should occur, the cloth will act as a damper and help prevent the rope from whipping. Raise hood of vehicle for added protection.

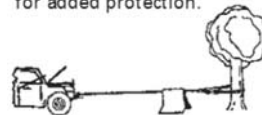



Figure 5

11. **NEVER USE YOUR WINCH FOR LIFTING OR MOVING PEOPLE.** 
12. Your winch is not intended for overhead hoisting operations.
13. **AVOID CONTINUOUS PULLS FROM EXTREME ANGLES** as this will cause the wire rope to pile up on one end of the drum (Figure 6). This can jam the wire rope in the winch, causing damage to the rope or the winch.

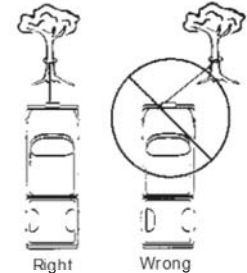



Figure 6

14. **NEVER OBSCURE THE WARNING INSTRUCTION LABELS.**
15. Always operate winch with an unobstructed view of the winching operation.
16. Equipment such as a tackle, hooks, pulley blocks, straps, etc. should be sized to the winching task and should be periodically inspected for damage that could reduce their strength.
17. **NEVER RELEASE FREESPOOL CLUTCH WHEN THERE IS A LOAD ON THE WINCH.**
18. **NEVER WORK ON OR AROUND THE WINCH DRUM WHEN WINCH IS UNDER LOAD.**
19. **DO NOT OPERATE WINCH WHEN UNDER THE INFLUENCE OF DRUGS, ALCOHOL OR MEDICATION.**

20. ALWAYS DISCONNECT WINCH POWER LEADS TO BATTERY BEFORE WORKING IN OR AROUND THE WINCH DRUM so that the winch cannot be turned on accidentally.
21. When moving a load, slowly take up the wire rope slack until it becomes taut. Stop, recheck all winching connections. Be sure the hook is properly seated. If a nylon sling is used, check the attachment to the load.
22. When using your winch to move a load, place the vehicle transmission in neutral, set vehicle brake, and chock all wheels.
23. DO NOT USE THE WINCH TO HOLD LOADS IN PLACE. Use other means of securing loads such as tie down straps. 
24. USE ONLY FACTORY APPROVED SWITCHES, REMOTE CONTROLS AND ACCESSORIES. Use of non-factory approved components may cause injury or property damage and could void your warranty.
25. DO NOT MACHINE OR WELD ANY PART OF THE WINCH. Such alterations may weaken the structural integrity of the winch and could void your warranty.
26. DO NOT CONNECT WINCH TO EITHER 110V AC HOUSE CURRENT OR 220V MAINS AS WINCH BURNOUT OR FATAL SHOCK MAY OCCUR.
27. Never allow shock loads to be applied to winch or wire rope.
28. Use caution when pulling or lowering a load up and down a ramp or incline. Keep people, pets and property clear of the path of the load.

INSTALLATION

WARNING Correct installation of your winch is required for proper operation.

This winch MUST be mounted with the wire rope in the underwind direction. Improper mounting could damage your winch and void your warranty.

MOUNTING YOUR WINCH

WARNING Improper mounting can cause personal injury.

MINIMUM ELECTRICAL REQUIREMENTS

A 60 amp alternator and battery with 440 cold-cranking amperes capacity are the minimum recommended power sources. If the winch is in heavy use, an auxiliary battery is recommended.

Step (1)
Install mounting kit or structural support for winch.

Step (2)
(See Figure 7) Attach fairlead to mounting plate using 2 bolts, nuts flat and lock washers, provided. Mount the winch to a mounting kit base plate or to the mount that you designed. Place square nuts inside slots on feet of winch. Thread 4 bolts with flat and lock washers provided into nuts in winch. The mounting plate must be flat and a minimum of 1/4" thick. The ends of the mounting bolts must not bottom out in the winch body, and must fully engage the threads in the nuts. Route end of wire rope through fairlead and attach device hook, use device pin and cotter pin to secure.

WARNING Do not substitute any strength grade weaker than ISO Grade 8.8.

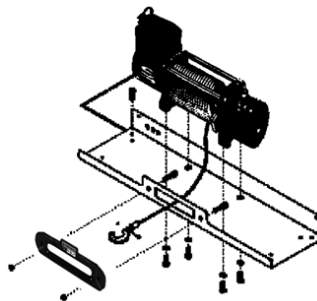

Figure 7

Step (3)

Disconnect the vehicle battery leads.

WARNING Batteries contain gasses which are flammable and explosive. Wear eye protection during installation and remove all metal jewelry. Do not lean over battery while making connections.

Route the long red and black color coded wires to the battery. To ensure against insulation abrasion and/or cutting, apply several layers of electrical tape where wiring may come in contact with sharp parts on the vehicle. Attach the circuit breaker directly to the end of the RED color coded wire using the bolt installed on the circuit breaker assembly. Then attach the circuit breaker assembly directly to the battery positive terminal, connecting the Circuit Breaker's Buss Bar labeled, "BAT" directly to the battery terminal. (See Figure 8)

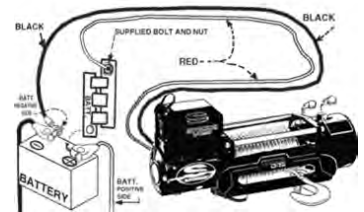
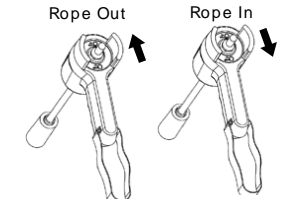

Figure 8

If your vehicle is equipped with side pole terminals, it may be necessary to obtain auxiliary side terminal bolts from your local auto parts dealer to make these connections. Connect the black color coded wire to the battery negative terminal, then reattach the terminal to the battery.

Step (4)

PENDANT OPERATION



The handheld pendant switch activates a solenoid that activates power to the winch motor. To connect the pendant control, remove the cover on the plug receptacle and insert the plug end of remote switch. The plug on the pendant control cord is keyed and will fit into the socket only one way. The switch trigger returns to the "Off" position when released. To change direction, move the toggle in the other direction.

CAUTION The switch assembly must be kept free of dirt and moisture to ensure safe operation.

CAUTION To prevent unauthorized use of the winch, remove pendant control and store in a clean dry area such as the glove box.

CAUTION If the winch motor stalls, do not continue to apply power.

FREESPOOL OPERATION

Step (5)
 (See Figure 9) Set the freespool clutch knob to the "Disengaged" position. If there is a load on the wire rope the clutch knob may not move easily. **DO NOT FORCE THE CLUTCH KNOB.** Release tension on the clutch by jogging out some of the wire rope. Pull several feet of wire rope off the drum. Return the clutch knob back to, "Engaged" position. Activate the winch in Cable Out momentarily to check drum rotation direction. If the drum rotates in the wrong direction, recheck your wiring. Release the clutch and pull out the wire rope and secure to anchor or load. Check that there are least five (5) turns of wire rope left on the drum. Re-engage the drum by returning the clutch knob to the "Engaged" position.

CAUTION Clutch must be fully engaged before winching. Never engage clutch knob while drum is turning.

INTERMITTENT DUTY

An electric winch is like any other motor driven power tool such as an electric drill or saw. The electric motor should not be allowed to become excessively hot. Normal precautions will extend the life of your motor. Keep the duration of pulls as short as possible. If the end of the motor becomes uncomfortably hot to touch, stop winching and allow the motor to cool down.

Reference No.	Description	Part Number
1	Wire Rope Assy-5/16" x94'	90-12870
2	Remote Control	90-12864
3	Solenoid (no cover)	90-12877
4	Motor	90-12867
5	Cover-Solenoid w/Socket	90-12878
6	Circuit breaker Assembly	90-22860
7	Hawse	90-12865

