

# SuperSway-Stops®

## SSS-4

Dodge 2500 2006-2013   Dodge 3500 2006-2018  
Dodge 4500 2007-2018   Dodge 5500 2007-2018

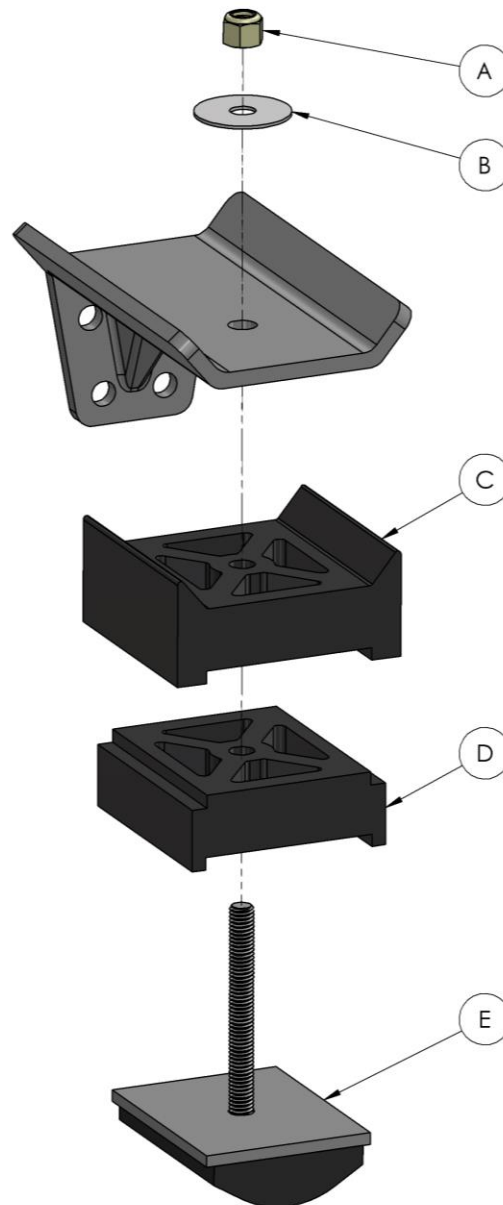

ITEM	PART NUMBER	DESCRIPTION
A	512323	3/8 NYLOCK NUT
B	512248	3/8 FENDER WASHER
C	311010	DODGE ADAPTER
D	311008	OPTIONAL 1" SPACER
E	311007	CONTACT PAD

## **Installation Instructions**

- 1) Park vehicle on level hard surface. Engage emergency brake and place wheel chocks at front wheels to prevent rolling. Observe all safety precautions and wear safety glasses.
- 2) Raise Rear of vehicle till factory top overload blade is seen relaxing its contact from frame perches, A gap of 4+” should suffice, employ c-clamp if blade needs to be compressed further to gain additional installation clearance. Support frame using safety jack stands.
- 3) Starting on the driver’s side front remove the OE overload perch bumpstop by unbolting it from the perch.
- 4) Starting with the Contact Pad (Item E) slide the Dodge Adapter (Item C) onto the stud and locate the Contact Pad into the channel of the Adapter. If more preload is desired, insert the Optional 1” Spacer (Item D) between the Contact Pad and Adapter.
- 5) Insert the stud through the hole in the overload perch from the bottom and center the Contact Pad over the overload leaf.
- 6) Install the fender washer (Item B) and 3/8 nut (Item A). Torque to 30 ft.-lbs.
- 7) Repeat steps above for the rear.
- 8) Repeat the above for the passenger’s side of the vehicle.
- 9) Jack up vehicle, remove safety jack stands. Carefully lower vehicle to the hard surface. Remove the wheel chocks. Release emergency brake.
- 10) Its recommended to road test and then observe SwayStops position, units should remain square to leaf blade with washer and nut in place and tight.
- 11) Re-torque nuts after 100-200 miles.
- 12) Fill out the included warranty card and send to SuperSprings.**

### **Important Notice.**

- 1) For easy installation please read instructions completely first and have all necessary tools available.
- 2) We recommend that this installation be done by a professional or persons with sound mechanical knowledge.
- 3) SuperSwayStops are designed to work with the original factory springs only.
- 4) These instructions are meant as a guide for the installation of SuperSwayStops. SuperSprings International assumes no liability for the actual installation process. Installers should apply common automotive safety practices when raising, lowering and working on vehicles.
- 5) SuperSwayStops are designed to enhance the vehicles load carrying performance and road handling however it does not authorize (or recommend) loading beyond the manufacturer's GVWR specifications.

***To prevent damage to the vehicle and to ensure safety, do not exceed the maximum load recommended by the vehicles manufacturer (GVWR).***