

SumoSprings Rear

Chevy 2500/3500 HD 2x4, 4x4 (2001-2010)

Part #SSR-211-40/47/54

Installation Instructions



FRONT

Driver's side (Passenger's side similar)

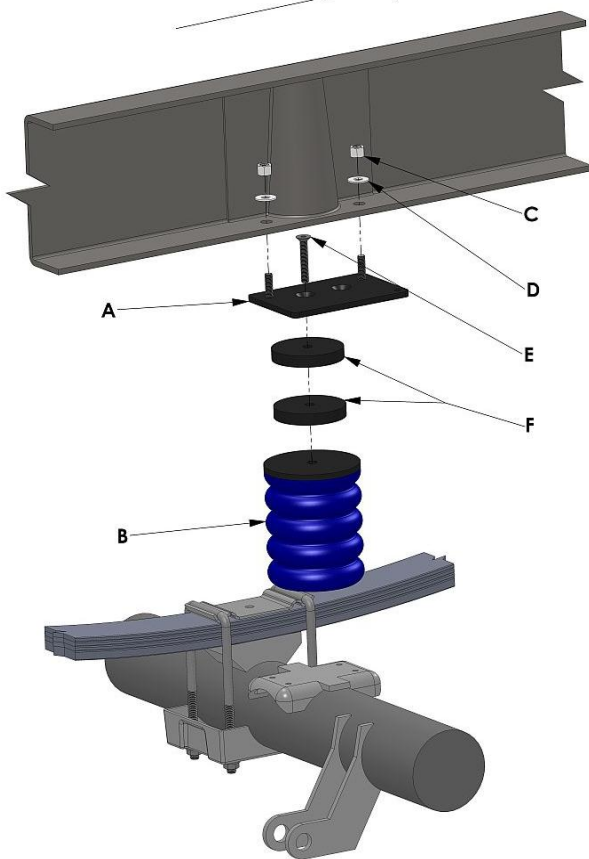

Parts List

Tool List

Floor Jack	1
Jack stands	2
Wheel blocks	4
3/16 Allen wrench	1
wrench	1

<u>Item</u>	<u>Part #</u>	<u>Description</u>	<u>Quant.</u>
A	512022	Top bracket	2
B	511440	SumoSpring 40 (blue) or	2 or
	511421	SumoSpring 47 (black) or	2 or
	511432	SumoSpring 54 (yellow)	2
C	512035	M8 Toplock Nut	4
D	512244	5/16" washers	4
E	512290	M8 x 50mm FHCS	2
F	512049	Urethane washers 3" dia. X 0.5"	4
	512210	Loc-Tite Sachet	4

Installation Instructions

- 1) Park vehicle on level hard surface. Place wheel blocks in front and behind the front wheels to prevent rolling. Observe all safety precautions and wear safety glasses.
- 2) Raise the rear of the vehicle allowing the axle to hang free and rest the frame on the safety jack stands rated for the vehicle. Removal of the rear wheels is optional.
- 3) Remove the factory jounce bumpers from the underside of the frame and set aside for possible re-installation in the eventuality that the SumoSprings may be removed at a later date.
- 4) Use Loc-Tite on the FHCS (512290) bolt threads and with an allen wrench secure the SumoSpring and urethane washers to the bracket.
- 5) On the driver side position the bracket with the SumoSpring offset to the rear of the vehicle and attach with the washers and toplock nuts.
- 6) Repeat the installation on the passenger side with the SumoSpring again offset to the rear of the vehicle
- 7) Jack up the vehicle; remove the jack stands.
- 8) If rear wheels were removed you can now reinstall the rear wheels.
- 9) Jack up vehicle, remove safety jack stands and lower the vehicle to the hard surface. Remove front wheel blocks.
- 10) Fill out warranty card and send to SuperSprings. The warranty card is an attached document.

Important Notice.

- 1) For easy installation please read instructions completely first and have all necessary tools available.
- 2) We recommend that this installation be done by a professional or persons with sound mechanical knowledge.
- 3) SumoSprings are designed to work with the original factory [springs](#) only.
- 4) These instructions are meant as a guide for the installation of SumoSprings. SuperSprings International assumes no liability for the actual installation process. Installers should apply common automotive safety practices when raising, lowering and working on vehicles.
- 5) SumoSprings are designed to enhance the vehicles load carrying performance and road handling however it does not authorize or recommend loading beyond the manufacturer's GVWR specifications.

To prevent damage to the vehicle and to ensure safety, do not exceed the maximum load recommended by the vehicles manufacturer (GVWR).