

SumoSprings Rear

Chevy 2500/3500 HD 2x4, 4x4 (2011~present)

Part #SSR-203-40-2 ~ SSR-203-47-2

Installation Instructions

Driver's side (Passenger's side similar)

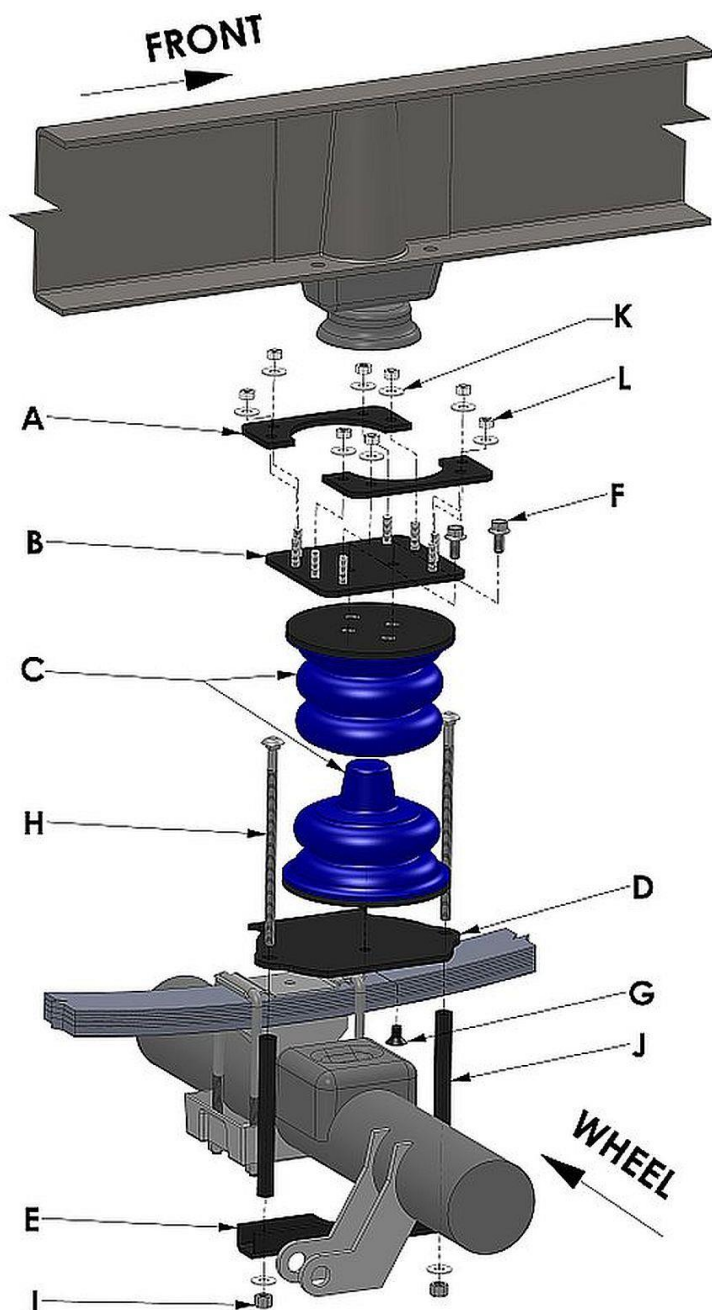

Parts List

Item	Part #	Description	Quant.
A	512052	Top upper bracket	4
B	512053	Top lower bracket	2
C	511419 or 511418	SumoSpring 40 (blue) or SumoSpring 47(black)	2 or 2
D	512051	Bottom bracket	2
E	512054	Axle Clamp	2
F	512207	3/8-16x 3/4" serrated flange bolts	4
G	512245	3/8-16 X 7/8" FHCS	2
H	512258	3/8x 7.5" grade 8 Carriage Bolts	4
I	512234	3/8 Top-lock nut	4
J	512055	Carriage bolt pipe sleeve	4
K	512244	5/16 USS Flat washers	20
L	112241	5/16-18 Top-lock nuts	16

Tool List

Floor Jack	1
Jack stands	2
Wheel blocks	4
9/16" wrench	2

Installation Instructions

1. Park vehicle on level hard surface. Place wheel blocks in front and behind the front wheels to prevent rolling. Observe all safety precautions and wear safety glasses.
2. Raise the rear of the vehicle allowing the axle to hang free and rest the frame on the safety jack stands rated for the vehicle. Removal of the rear wheels is optional.
3. Remove the factory jounce bumpers from the underside of the frame and set aside for possible re-installation in the eventuality that the SumoSprings may be removed at a later date.
4. Starting on the driver's side assemble the Bottom bracket assembly by attaching the bottom bracket (Item D) to the Sumospring lower (Item C) using a 3/8-16 x 3/4" FHCS (Item G).
5. Place the bottom bracket assembly in position above the jounce pad and then with a "tilt and twist" action ensure that the ears on the Bottom bracket (Item D) achieve a snug fit between the factory u-bolts and the factory spring-pack and resting on the jounce pad.
6. Drop two 3/8" by 7.5" carriage bolts (Item H) through the Bottom bracket. Thread two pipe sleeves (Item J) onto the carriage bolts and attach the Axle clamp (Item E) to the carriage bolts using two 5/16" USS washers (Item K) and two 3/8-16 Top-lock nuts (Item I).
7. Assemble the top bracket assembly by attaching the top lower bracket (Item B) to the Sumospring upper (Item C) using two 3/8-16 x 3/4" serrated flange bolts (Item F). Attach the two Top upper brackets (Item A) to the Top lower bracket (Item B) ensuring a firm grip onto the factory bump-stop receptacle using eight 3/8" USS flat washers (Item H) and eight 3/8-16 Top-lock nuts (Item I). It is important to orientate the top lower bracket (Item B) to be off-set closest to the tire prior to bolting. Prior to tightening the eight 3/8-16 top-lock nuts (Item L) ensure that the top bracket assembly aligns well with the installed bottom bracket assembly.
8. Repeat steps three through seven on the passenger's side of the vehicle.
9. If rear wheels were removed you can now reinstall the rear wheels.
10. Jack up vehicle, remove safety jack stands and lower the vehicle to the hard surface. Remove front wheel blocks.
11. Fill out warranty card and send to SuperSprings. The warranty card is an attached document.

Important Notice.

- 1) For easy installation please read instructions completely first and have all necessary tools available.
- 2) We recommend that this installation be done by a professional or persons with sound mechanical knowledge.
- 3) SumoSprings are designed to work with the original factory springs only.
- 4) These instructions are meant as a guide for the installation of SumoSprings. SuperSprings International assumes no liability for the actual installation process. Installers should apply common automotive safety practices when raising, lowering and working on vehicles.
- 5) SumoSprings are designed to enhance the vehicles load carrying performance and road handling however it does not authorize or recommend loading beyond the manufacturer's GVWR specifications.

To prevent damage to the vehicle and to ensure safety, do not exceed the maximum load recommended by the vehicles manufacturer (GVWR).

SumoSprings Rear

Suspension Enhancement

GM 2500/3500 HD Pickup [2011 ~ present]

SumoSprings Part# SSR-203-40-2 ~ SSR-203-47-2



Installation



SSR-203-40-2

Installed