

SuperSprings®

Ford F53 Motor Home (24K-26K GVWR)

[2008 ~ present]

Part #SSR-183-54-1

Drivers Side (Passenger Side Similar)

Parts List

<u>Item</u>	<u>Part #</u>	<u>Description</u>	<u>Quant.</u>
A	512037	Upper frame bracket	2
B	511401	SumoSpring	2
C	512108	Lower bracket	2
D	512042	U- bracket strap	2
E	512207	3/8-16 x 3/4" serrated flange hex bolt	6
F	512301	3/8-16x 1.5" Serrated flange hex bolt	8
G	512292	3/8-16 x 5" carriage bolts	4
H	512302	3/8-16 Top lock flange nuts	12

Tool List

Floor Jack	1
Jack stands	2
Wheel blocks	4
9/16" wrench	2
Drill	1
7/16" Drill Bit	1

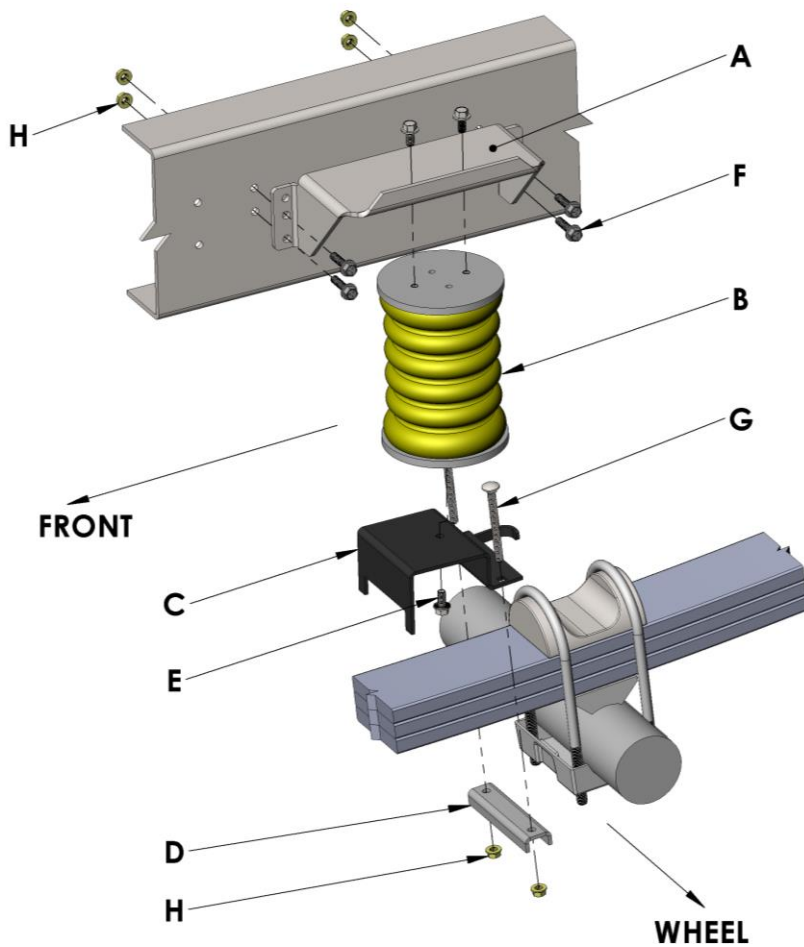

Diagram

A

Installation Instructions*

- 1) Park vehicle on level hard surface. Engage emergency brake. Place blocks in front and behind front wheels to prevent rolling. Observe all safety precautions and wear safety glasses.
- 2) Raise rear of vehicle allowing the axle to hang freely. Support the frame using safety jack stands.
- 3) Attach Upper Frame bracket (Item A) to the top of the SumoSpring (Item B) using two 3/8-16x3/4" serrated flange hex bolts (Item E). Attach the Lower bracket (Item C) to the bottom of the SumSpring using one 3/8-16x3/4" serrated flange hex bolt (Item E) as in Diagram A above.
- 4) Insert two 3/8-16 x 4" carriage bolts (Item G) into the two square openings in the lower bracket (Item C) in such a way that they straddle the factory [spring-pack](#). Position the lower bracket so that the curved side finger captures the factory u-bolt (see Diagram B below).
- 5) Secure the lower bracket (Item C) to the factory spring-pack using the u-bracket strap (Item D) the two carriage bolts (Item G) two 5/16" washers (Item H) and two 3/8-16 Top-lock nuts (Item I).



Diagram B

- 6) Repeat steps three through five on the opposite side of the vehicle.
- 7) Jack up the axle until Upper Frame Bracket (Item A) is in correct position on frame. Drill the two lower holes using a 7/16" drill bit exactly mid height on the frame as seen in Diagram C below.
- 8) Insert two 3/8-16 x 1.25" hex bolts, 5/16" washers, and 3/8" top lock nuts in lower holes as seen in Diagram A.

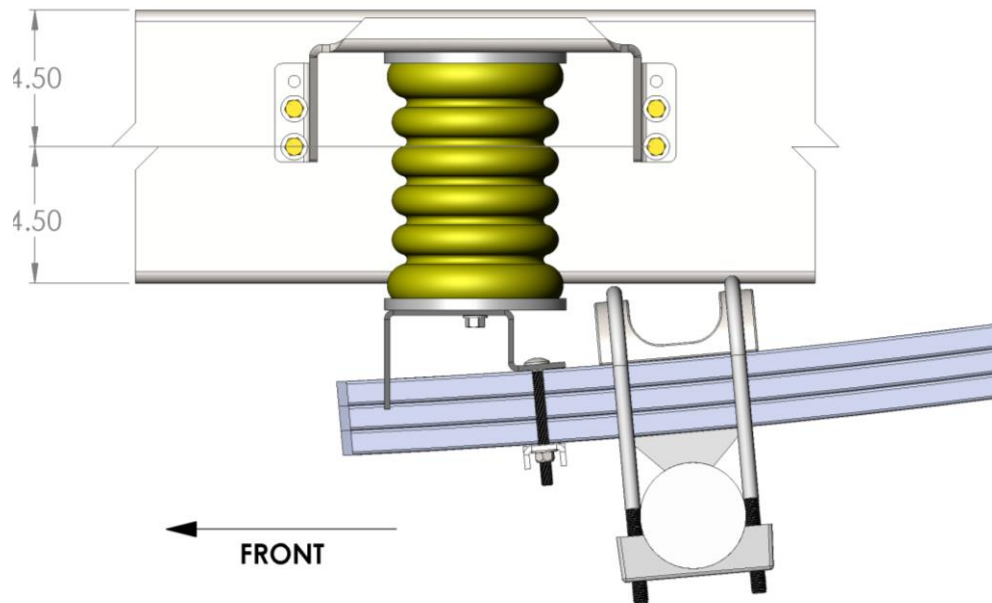

Diagram C

- 9) Using the Upper Bracket holes as a guide, drill two upper holes using a 7/16" drill bit (ensure clearance on all cables/service lines inside the frame prior to drilling).
- 10) Insert two 3/8-16 x 1.25" hex bolts, 5/16" washers, and 3/8" top lock nuts in upper holes as seen in Diagram A.
- 11) Repeat step seven through ten on opposite side.
- 12) Carefully lower vehicle to the hard surface. Remove the blocks in front and back of the rear wheels
- 13) Release emergency brake.
- 14) Fill out warranty card and send to SuperSprings. The warranty card is on the reverse side of this page.

***Contact factory if installation brackets create conflict with coach plumbing/electrical hardware.**

Important Notice.

- 1) For easy installation please read instructions completely first and have all necessary tools available.
- 2) We recommend that this installation be done by a professional or persons with sound mechanical knowledge.
- 3) SumoSprings are designed to work with the original factory springs only.
- 4) These instructions are meant as a guide for the installation of SumoSprings. SuperSprings International assumes no liability for the actual installation process. Installers should apply common automotive safety practices when raising, lowering and working on vehicles.
- 5) SumoSprings are designed to enhance the vehicles load carrying performance and road handling however it does not authorize (or recommend) loading beyond the manufacturer's GVWR specifications.

To prevent damage to the vehicle and to ensure safety, do not exceed the maximum load recommended by the vehicles manufacturer (GVWR).