

PRIMARY APPLICATION

FORD
F-150 Raptor 4x4 (2010-2014)*
F-150 Raptor 4x4 (2017-2020)*

* RAPTOR MODELS ONLY.

TOOLS REQUIRED

- 1 Floor Jack
- 2 Jack Stands
- 1 13mm Socket
- 1 15mm Socket
- 1 Ratchet w/extension
- 1 9/16" Wrench
- 4 Wheel Blocks

PARTS LIST

Item	QTY	Part#	Description
A	2	512207	3/8-16 x 3/4" Bolt
B	2	512114	Mounting bracket
C	2	512312	M10-1.5 x 30mm Bolt
D	2	511411	SumoSprings Black (-47)
	2	512117	1" Spacer
	2	512274	3/8-16 x 1-3/4" Bolt
	1	512239	Blue Thread Locker

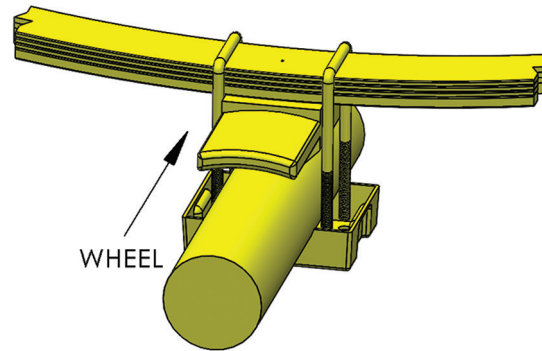
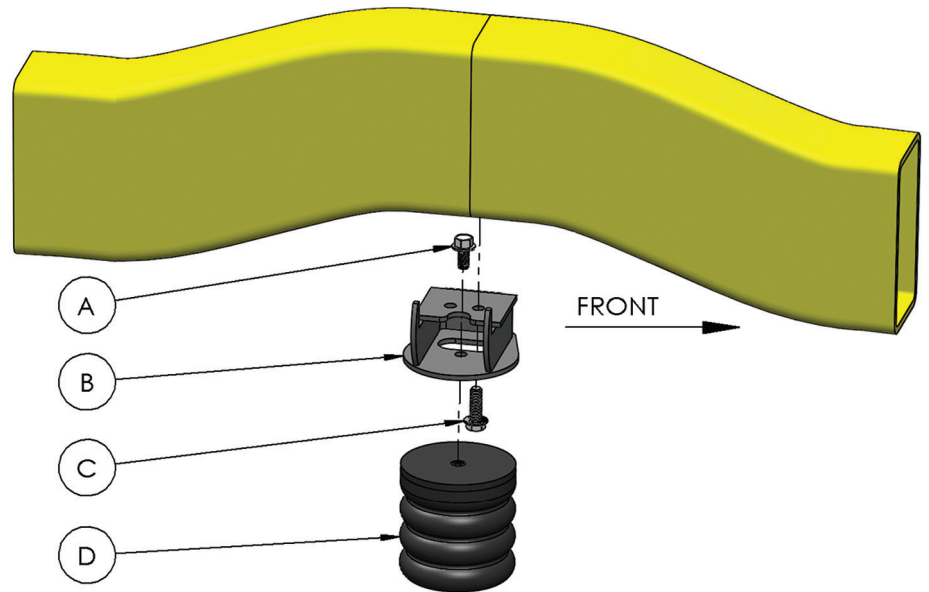

APPROXIMATE INSTALL TIME

🕒 1.5 Hours

⚠️ Never exceed the manufacturer's Gross Vehicle Weight Rating (GVWR) located on your vehicle's identification tag.

SAFETY NOTICE: We recommend installation be done by a professional or persons with sound mechanical knowledge.

WARNING: These instructions are a general guide for installation. SuperSprings International, Inc. assumes no liability for the actual installation process. Consumers and installers should apply common automotive safety practices when raising and working on any vehicle. **Do not put yourself in a position where, if the vehicle were to move**

unexpectedly, you may be injured. SuperSprings' products are designed to improve vehicle ride quality. Do not load any vehicle beyond the manufacturer's specifications.

BEFORE INSTALLATION: Ensure the vehicle is on a level surface, the parking brake is ON, with the ignition OFF, and place blocks in front of and behind the front tires to prevent the vehicle from moving.

DURING AND/OR AFTER INSTALLATION: Ensure emergency brake cables are not touching the SuperSprings. Secure any cables out of the way with zip ties or by re-routing. **Ensure all A/C lines, brake cables and frame are clear of contact or interference.**

1. Park vehicle on level hard surface. Engage emergency brake. Place blocks in front and behind front wheels to prevent rolling. Observe all safety precautions and wear safety glasses.
2. Raise rear of vehicle allowing the axle to hang freely. Support the frame using safety jack stands.
3. Remove existing factory jounce bumper assembly by removing 10mm bolt in the center of the jounce using a 13mm socket and ratchet w/extension.
4. Remove SumoSprings assembly from box and disassemble components.
5. When installing the SumoSprings use a drop or two of blue thread locker on the threads of each bolt.
6. Using the supplied **M10-1.5x30 bolt** (ITEM C), attach the **Mounting Bracket** (ITEM B) to frame in the same location as the factory jounce bumper as shown in the diagram. Be sure the locating-tangs are on the inside of the frame and use the forward bolt hole in the bracket, to center the SumoSprings over the axle.
7. Attach the **SumoSprings Black [-47]** (ITEM D) to bracket using the **3/8-16 x 3/4" Bolt** (ITEM A) as seen in the diagram. If more preload is required, install the **1" Spacer** between the SumoSprings and the bracket using the **3/8-16x1-3/4" Bolt**.
8. Repeat procedure on the other side.
9. Jack up vehicle, remove safety jack stands.
10. Carefully lower vehicle to the hard surface. Remove the blocks in front and back of the front wheels.
11. Release emergency brake.
12. Fill out warranty information at: supersprings.com/warranty/



Never exceed the manufacturer's Gross Vehicle Weight Rating (GVWR) located on your vehicle's identification tag.

SAFETY NOTICE: We recommend installation be done by a professional or persons with sound mechanical knowledge.

WARNING: These instructions are a general guide for installation. SuperSprings International, Inc. assumes no liability for the actual installation process. Consumers and installers should apply common automotive safety practices when raising and working on any vehicle. **Do not put yourself in a position where, if the vehicle were to move**

unexpectedly, you may be injured. SuperSprings' products are designed to improve vehicle ride quality. Do not load any vehicle beyond the manufacturer's specifications.

BEFORE INSTALLATION: Ensure the vehicle is on a level surface, the parking brake is ON, with the ignition OFF, and place blocks in front of and behind the front tires to prevent the vehicle from moving.

DURING AND/OR AFTER INSTALLATION: Ensure emergency brake cables are not touching the SuperSprings. Secure any cables out of the way with zip ties or by re-routing. **Ensure all A/C lines, brake cables and frame are clear of contact or interference.**