

# SumoSprings Rear

Ford F250/F350 Super Duty, 2017-2018, 4x4

Part #SSR-128-40-2 ~ SSR-128-47-2

Drivers side (Passenger's side similar)

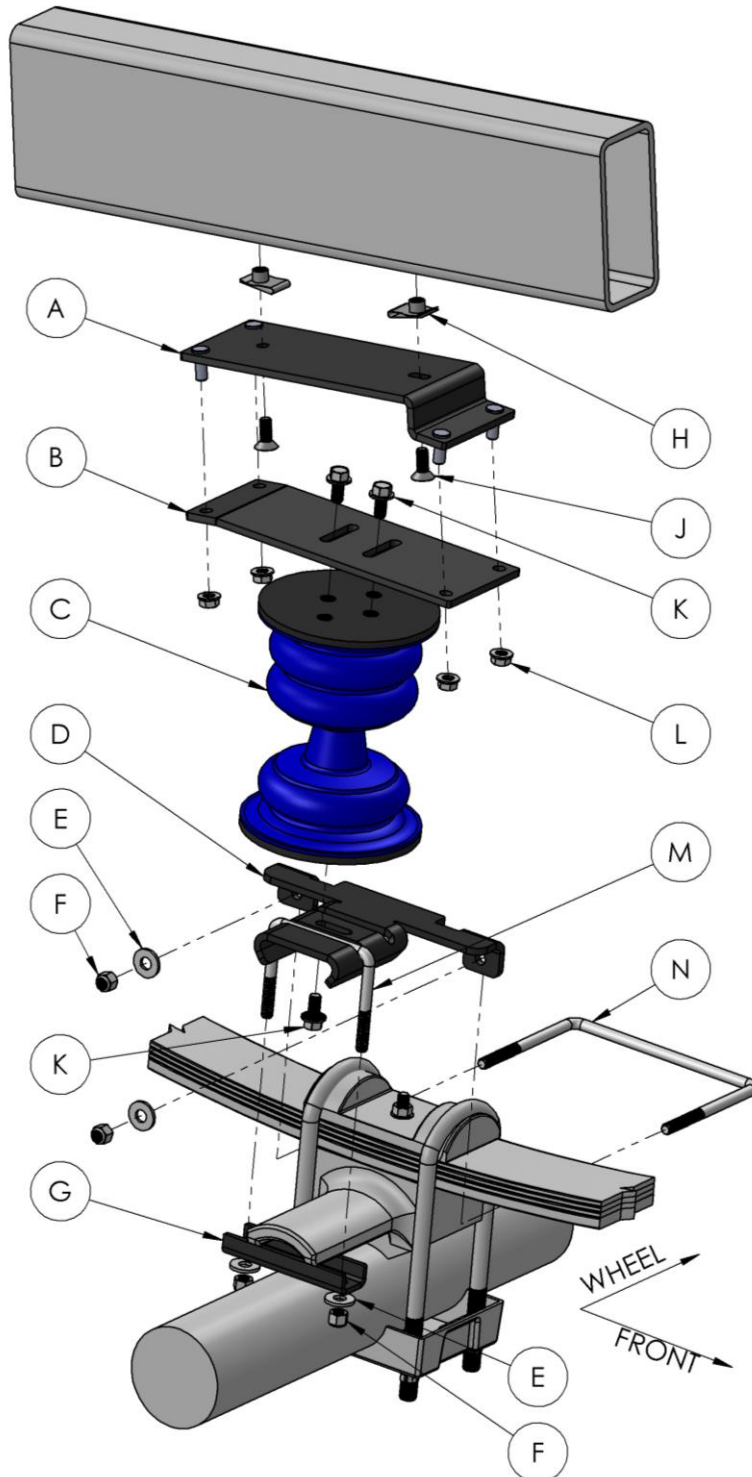

Item	Part #	Description	Quant.
A	512344	Upper bracket 1	2
B	512345	Upper bracket 2	2
C	511419	Blue Sumo Spring-40	2
	511418	Black Sumospring-47	2
D	512346	Lower bracket	2
E	512244	5/16 Flat washer	8
F	512323	3/8-16x Nyloc nut	8
G	512136	U-channel clamp	2
H	512356	3/8-16 Clip nut	4
J	512340	3/8-16x1" FHCS	4
K	512207	3/8-16x3/4" Serrated flange bolt	6
L	512302	3/8 Flanged lock nut	8
M	112195	3/8 U-bolt 3.5"x3.5"	2
N	112196	3/8 U-bolt 7.125"x 5"	2

## **Installation Instructions**

- 1) Park vehicle on level hard surface. Place wheel blocks in front and behind the front wheels to prevent rolling. Observe all safety precautions and wear safety glasses.
- 2) Raise the rear of the vehicle allowing the axle to hang free and rest the frame on the safety jack stands rated for the weight of the vehicle. Removal of the rear wheels is optional.
- 3) Starting on the driver's side un-bolt and remove the factory jounce bumpers from the underside of the frame and remove the factory studs that are clipped into the frame.
- 4) Attach two 3/8 clip nuts (item H) onto the frame where the factory studs were positioned. Ensure that the threaded portion is up inside the frame.
- 5) Using the two 3/8-16 FHCS (item J), attach the upper bracket 1 (item A) to the frame with the bent end toward the front of the vehicle as in the diagram on page 1. Place a drop of the blue locktite on the threads of each bolt.
- 6) Using two 3/8 serrated flange bolts (item K) attach the top half of the SumoSPring (item C) to the upper bracket 2 (item B). Leave the bolts slightly loose so that the position of the SumoSPring can be adjusted.
- 7) Place the upper bracket 2 and SumoSPring assembly (items B & C) onto the studs of the upper bracket 1 (item A). The end of item B with the bend goes toward the rear of the truck as in the diagram on page 1. Fasten the brackets together with four 3/8 flanged lock nuts (item L).
- 8) Place one 3/8x3.5"x3.5" u-bolt (item M) outer groove of the lower bracket (item D) as seen in diagram on page 1.
- 9) Using one 3/8 serrated flange bolt (item K) attach the lower half of the SumoSPring to the lower bracket (item D). Leave the bolt slightly loose so that the position can be adjusted.
- 10) Place the lower assembly on the bump stop contact perch and position tight to the leaf pack.
- 11) Align upper and lower halves of the SumoSPring using a jack to raise the axle if necessary.
- 12) Once the top and bottom of the SumoSPring are lined up, tighten the bolts (item K).
- 13) Place the 3/8x 7.125"x5" u-bolt (item N) around the factory u-bolts and below the leaf pack so that the ends protrude through the holes in the lower bracket (item D) and fasten securely with washers (item E) and nyloc nuts (item F).
- 14) Place the U-channel clamp (item G) over the ends of the smaller u-bolt (item M) and fasten tight to the bottom of the bump stop perch using the washers (item E) and nyloc nuts (item F).
- 15) Repeat steps 3-14 on passenger side of truck.
- 16) If rear wheels were removed you can now reinstall the rear wheels and torque wheel nuts to manufacturer's spec.
- 17) Jack up vehicle, remove safety jack stands.
- 18) Remove wheel blocks from the front wheels.
- 19) Fill out warranty card and send to SuperSprings. The warranty card is an attached document.

### **Important Notice.**

- 1) For easy installation please read instructions completely first and have all necessary tools available.
- 2) We recommend that this installation be done by a professional or persons with sound mechanical knowledge.
- 3) SumoSPrings are designed to work with the original factory springs only. If they have been replaced with aftermarket springs then please consult with SuperSprings International.
- 4) These instructions are meant as a guide for the installation of SumoSPrings. SuperSprings International assumes no liability for the actual installation process. Installers should apply common automotive safety practices when raising, lowering and working on vehicles.
- 5) SumoSPrings are designed to enhance the vehicle's load carrying performance and road handling however it does not authorize (or recommend) loading beyond the manufacturer's GVWR specifications.

***To prevent damage to the vehicle and to ensure safety, do not exceed the maximum load recommended by the vehicle's manufacturer (GVWR).***