

SumoSprings Rear

Ford F250/F350 Super Duty 2x4, 4x4 (2017)

Part #SSR-127-40/47/54

Installation Instructions

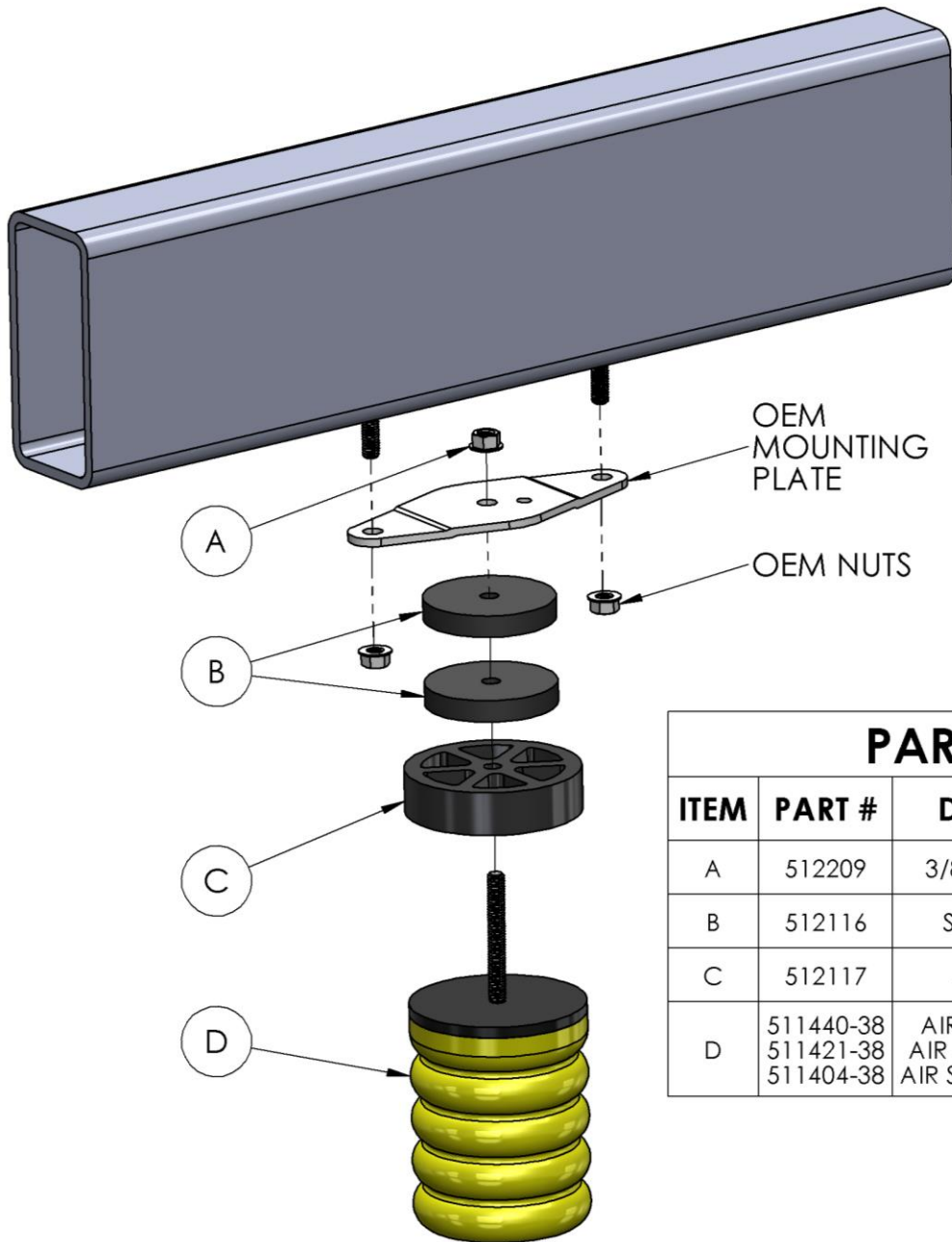

PARTS LIST

ITEM	PART #	DESCRIPTION	QNTY.
A	512209	3/8-16 FLANGE NUT	2
B	512116	SPACER 3" x 1/2"	4
C	512117	SPACER 4" x 1"	2
D	511440-38 511421-38 511404-38	AIR SPRING -40 BLUE AIR SPRING -47 BLACK AIR SPRING -54 YELLOW	2

Installation Instructions

- 1) Park vehicle on level hard surface. Place wheel blocks in front and behind the front wheels to prevent rolling. Observe all safety precautions and wear safety glasses.
- 2) Raise the rear of the vehicle allowing the axle to hang free and rest the frame on the safety jack stands rated for the weight of the vehicle. Removal of the rear wheels is optional.
- 3) Starting on the driver's side un-bolt and remove the two nuts holding the OEM jounce bumper mounting plate to the underside of the frame.
- 4) Remove the OEM jounce bumper from the OEM mounting plate.
- 5) Assemble the Sumospring and spacers as indicated in the diagram. The diagram shows the configuration for the least air gap and soonest engagement. If more air gap (less engagement) is desired, one of the ½" spacers or the 1" spacer can be removed. **ATTENTION: AT LEAST ONE OF THE 512116 ½" SPACERS MUST BE USED FOR PROPER FIT TO OEM MOUNTING PLATE.**
- 6) Reinstall the OEM mounting plate with Sumospring assembly to the frame in the OEM location using the OEM mounting nuts.
- 7) Repeat steps three through six on the passenger's side of the vehicle.
- 8) If rear wheels were removed you can now reinstall the rear wheels and torque wheel nuts to manufacturer's spec.
- 9) Jack up vehicle, remove safety jack stands.
- 10) Remove wheel blocks from the front wheels.
- 11) Fill out warranty card and send to SuperSprings. The warranty card is an attached document.

Important Notice.

- 1) For easy installation please read instructions completely first and have all necessary tools available.
- 2) We recommend that this installation be done by a professional or persons with sound mechanical knowledge.
- 3) SumoSprings are designed to work with the original factory springs only. If they have been replaced with aftermarket springs then please consult with Supersprings International.
- 4) These instructions are meant as a guide for the installation of SumoSprings. SuperSprings International assumes no liability for the actual installation process. Installers should apply common automotive safety practices when raising, lowering and working on vehicles.
- 5) SumoSprings are designed to enhance the vehicles load carrying performance and road handling however it does not authorize (or recommend) loading beyond the manufacturer's GVWR specifications.

To prevent damage to the vehicle and to ensure safety, do not exceed the maximum load recommended by the vehicles manufacturer (GVWR).