

# SummoSprings Rear

Ford F550 Super Duty 2x4, 4x4 (2017)

Part #SSR-120-54

Installation Instructions

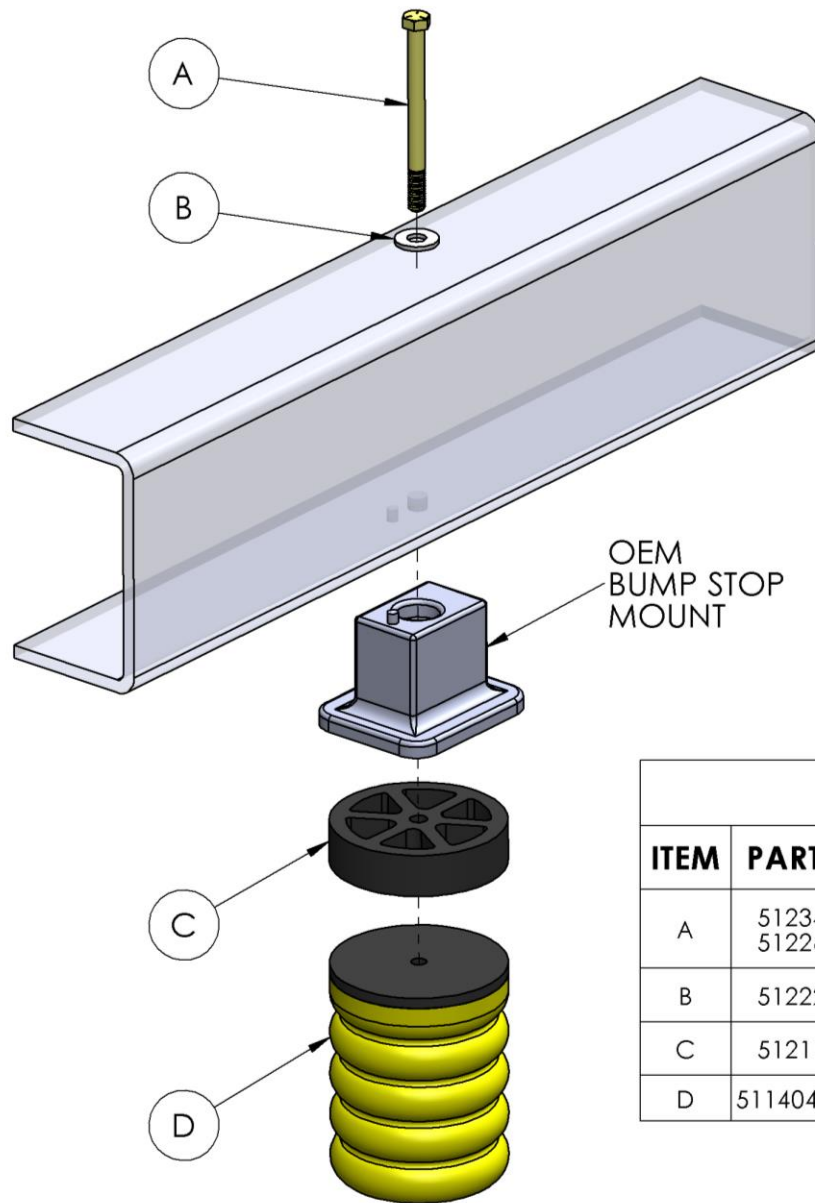

## PARTS LIST

ITEM	PART #	DESCRIPTION	QNTY.
A	512342 512265	3/8-16 x 4.5" HEX BOLT 3/8-16 x 3.5" HEX BOLT	2
B	512227	3/8" FLAT WASHER	2
C	512117	SPACER 4" x 1"	2
D	511404-38	AIR SPRING -54 YELLOW	2

## **Installation Instructions**

- 1) Park vehicle on level hard surface. Place wheel blocks in front and behind the front wheels to prevent rolling. Observe all safety precautions and wear safety glasses.
- 2) Raise the rear of the vehicle allowing the axle to hang free and rest the frame on the safety jack stands rated for the weight of the vehicle. Removal of the rear wheels is optional.
- 3) Starting on the driver's side un-bolt and remove the nut holding the OEM jounce bumper and mounting bracket to the underside of the frame.
- 4) Remove the OEM jounce bumper from the OEM cast steel mounting bracket by supporting the bracket and driving the jounce bumper stud through with a mallet.
- 5) Assemble the Sumospring and spacer to the frame as indicated in the diagram. Be sure to apply blue Loctite to the threads of the bolt. The diagram shows the configuration for the least air gap and soonest engagement. If more air gap (less engagement) is desired, the 1" spacer can be removed. **ATTENTION: If spacer is used then the 4.5" bolt must be used. If no spacer is used then use the 3.5" bolt.**
- 6) Repeat steps three through six on the passenger's side of the vehicle.
- 7) If rear wheels were removed you can now reinstall the rear wheels and torque wheel nuts to manufacturer's spec.
- 8) Jack up vehicle, remove safety jack stands.
- 9) Remove wheel blocks from the front wheels.
- 10) Fill out warranty card and send to SuperSprings. The warranty card is an attached document.

### **Important Notice.**

- 1) For easy installation please read instructions completely first and have all necessary tools available.
- 2) We recommend that this installation be done by a professional or persons with sound mechanical knowledge.
- 3) SumoSprings are designed to work with the original factory springs only.
- 4) These instructions are meant as a guide for the installation of SumoSprings. SuperSprings International assumes no liability for the actual installation process. Installers should apply common automotive safety practices when raising, lowering and working on vehicles.
- 5) SumoSprings are designed to enhance the vehicle's load carrying performance and road handling however it does not authorize (or recommend) loading beyond the manufacturer's GVWR specifications.

***To prevent damage to the vehicle and to ensure safety, do not exceed the maximum load recommended by the vehicle's manufacturer (GVWR).***