

SumoSprings Rear

Ford F250/F350 Super Duty 2x4, 4x4 (1999-Present)

Part #SSR-114-47/54

Installation Instructions

2005-Present

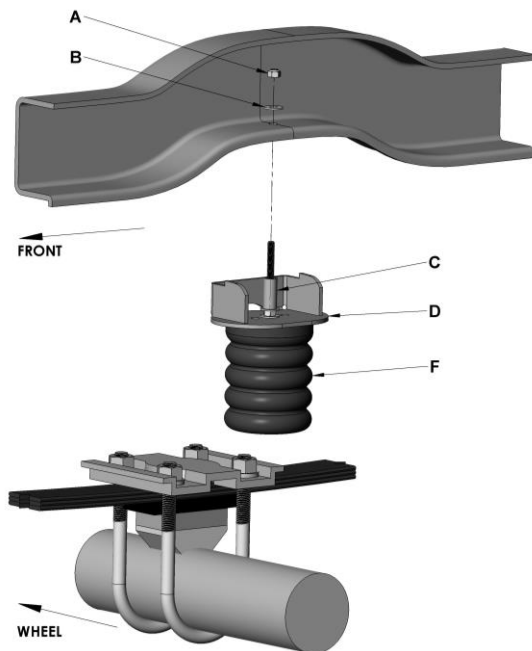

1999-2004

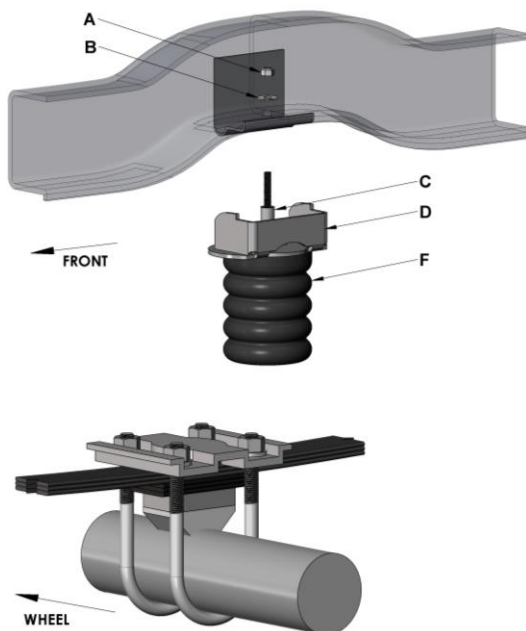

Parts List

<u>Item</u>	<u>Part #</u>	<u>Description</u>	<u>Quant.</u>
A	512219	8 mm nylock nut	2
B	512215	8mm Washer	6
C	512113	Steel pipe spacer	2
D	512112	Bracket-R Rev Ford 5th Wheel	2
E	512259-4.0	M8 x 4.0" studs	2
F	511421 or 511432	Airspring F-4050-35FC (SSR-102-47) or Airspring J4050-54FC (SSR102-54)	2
G	512214	8 mm hex nut	2
	512239	Loctite sachet	1

Tool List

Floor Jack	1
Jack stands	2
Wheel blocks	4
9/16" wrench	2

Installation Instructions

- 1) Park vehicle on level hard surface. Place wheel blocks in front and behind the front wheels to prevent rolling. Observe all safety precautions and wear safety glasses.
- 2) Raise the rear of the vehicle allowing the axle to hang free and rest the frame on the safety jack stands rated for the weight of the vehicle. Removal of the rear wheels is optional.
- 3) Starting on the driver's side un-bolt and remove the factory jounce bumper from the underside of the frame and set aside.
- 4) Assemble the parts as indicated in the diagram overleaf.
- 5) Attach the assembly to the underside of the frame, utilizing the same hole in the underside of the frame from which the factory bump-stop was removed, using the 8mm nylock nut (Item A) and 8mm washer (Item B).
- 6) On 2005-2015 trucks, the mounting bracket (Item D) will have its open face away from the wheel. On 1999-2004 vehicles with the convoy clip, the mounting bracket (item D) will have its open face toward the wheel. Consult diagrams on page 1.
- 7) Repeat steps three through five on the passenger's side of the vehicle.
- 8) If rear wheels were removed you can now reinstall the rear wheels and torque wheel nuts to manufacturer's spec.
- 9) Jack up vehicle, remove safety jack stands.
- 10) Remove wheel blocks from the front wheels.
- 11) Fill out warranty card and send to SuperSprings. The warranty card is an attached document.

Important Notice.

- 1) For easy installation please read instructions completely first and have all necessary tools available.
- 2) We recommend that this installation be done by a professional or persons with sound mechanical knowledge.
- 3) SumoSprings are designed to work with the original factory springs only.
- 4) These instructions are meant as a guide for the installation of SumoSprings. SuperSprings International assumes no liability for the actual installation process. Installers should apply common automotive safety practices when raising, lowering and working on vehicles.
- 5) SumoSprings are designed to enhance the vehicle's load carrying performance and road handling however it does not authorize (or recommend) loading beyond the manufacturer's GVWR specifications.

To prevent damage to the vehicle and to ensure safety, do not exceed the maximum load recommended by the vehicle's manufacturer (GVWR).