

SumoSprings Rear

Ford E350/E450 Super Duty (2004-present)

Part #SSR-106-40-2 ~ SSR-106-47-2

Installation Instructions

Drivers side (Passenger's side similar)

Parts List

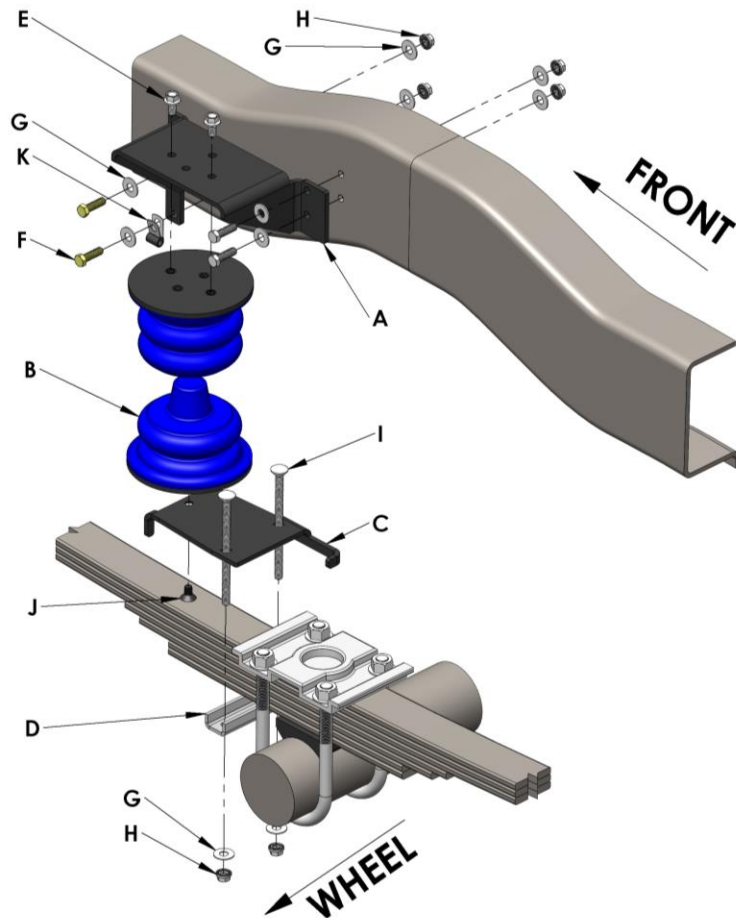

Item	Part #	Description	Qty.
A	512067/8	Upper bracket (passenger/driver)	1 +1
B	511415	SumoSpring-40-2 (blue)	2
	511412	SumoSpring-47- 2 (black)	2
C	512066	Lower bracket	2
D	512047	Bracket strap	2
E	512207	3/8-16x 3/4" serrated flange hex head bolt	4
F	512223	3/8-16x1 1/4" hex head bolt	8
G	512227	3/8" washers	20
H	512209	3/8-16 serrated flange hex nuts	8
I	512210	3/8-16 x 6" carriage bolt	4
J	512245	3/8-16x 7/8" FHCS	2
K	512285	3/8 P-Clamp	1
L	512234	3/8-16 Top-lock nuts	4

Tool List

Floor Jack	1
Jack stands	2
Wheel blocks	4
9/16" wrench	1
9/16" socket and wrench	1
Electric drill plus 3/8" drill bit	1
7/32" Allen wrench	1

NOTE: BEFORE STARTING, ENSURE CLEARANCE BETWEEN FRAME AND INSIDE OF TIRE IS 7" MINIMUM

Installation Instructions

- 1) Park vehicle on level hard surface. Place wheel blocks in front and behind the front wheels to prevent rolling. Observe all safety precautions and wear safety glasses.
- 2) Using a properly rated floor jack, raise the back of the vehicle by placing the jack under the center of the differential. Raise the vehicle far enough so that the rear wheels can be removed and the installation can be performed comfortably.
- 3) Place properly rated safety stands under the frame and lower the axle, if necessary, to be able to remove the rear wheels. Removal of the rear wheels is optional.
- 4) Open the SumoSprings carton and remove the contents. Starting on the driver's side (see diagram on page 1). Select the upper bracket (Item A-#512068), a SumoSpring (item B) and a lower bracket (item C-#512066). Attach the upper bracket to the top of the SumoSpring using two 3/8"-16 X .75" serrated flange bolts utilizing the two wider set of holes that have a 2.75" centerline. Attach the lower bracket to the underside of the SumoSpring using the 3/8"-16 X .75" flat-head capscrew (item J #512245) with a 7/32" Allen wrench. Align the lower bracket parallel to the upper bracket as shown and torque all attaching bolts to 35 foot pounds.
- 5) Remove the spring that holds the emergency brake cable in position on the outside of the left frame rail. Relocate the spring to the hole in the brake-line bracket as shown and attach the other end to the emergency brake cable. See pictures below.



- 6) Place the SumoSpring assembly on top of the leaf spring pack immediately forward of the u-bolt attaching plate, ensuring that the hook on the lower bracket is behind the forward u-bolt on the inside of the leaf spring. If there is a cable clamp bolt protruding from the outside of the frame on the driver's side this threaded stud will damage the Sumospring and needs to be trimmed back. Alternatively you can remove the nut and install washers onto the bolt inside of the frame then replace the nut to reduce the bolt protrusion and eliminate damage to the Sumospring. See picture of bolt at right.



- 7) Attach the lower bracket to the leaf spring pack using the two 3/8"-16 X 6.00" carriage bolts. Place the bracket strap (item D-#512047), grooved side up, over the bolts under the leaf spring pack and retain with 3/8" X 16 lock nuts and washers. Ensure that the bracket is against the u-bolt attaching plate and the hook properly engages the u-bolt. Tighten the nuts securely.

8) The front two holes in the bracket will align with two 5/16" factory holes that are vertically situated just behind the sway-bar attaching link. See marked picture at right. The three holes marked with arrows are all used and to be enlarged to 3/8". The axle may have to be raised or lowered to achieve the correct height for bolt alignment.



9) Ensure that all electrical, fuel, brake lines and other items are moved from inside the frame prior to drilling in all locations. It is recommended that a small piece of wood be placed inside the frame between the lines etc. to eliminate possible damage from the drill bit. Use this procedure whenever drilling during this installation.

10) Enlarge these 5/16" holes with a 3/8" drill bit using the bracket as a template.

11) Loosely attach the bracket using a 3/8" -16 X 1.00" bolt, nut and washers through the front top hole. Place the 3/8" P-clamp (512285) around the emergency brake cable so the cable will pass under the bracket and the hole in the clamp will align with the lower front hole in the bracket. Attach the P-clamp to the bracket by inserting a 3/8" bolt and washer through the hole in the clamp and through the lower hole in the bracket. Loosely attach with washer and nut.



12) The top hole in the rear of the bracket will align with a 5/16" hole in the frame (marked with a white arrow above). Check for clearance on the inside of the frame and enlarge this 5/16" hole to 3/8" hole using a 3/8" drill bit using the bracket as a template. Using the bracket as a template again, drill a 3/8" hole in the frame through the lowest hole in the rear of the bracket after again checking behind the area for lines and wires. Insert two 3/8" - 16 X 1.00" bolts, nuts and washers and tighten all four of the bracket attaching bolts securely.

13) Repeat steps four through twelve on the passenger side of the vehicle (with exception of P-clamp attaching detail).

14) If rear wheels were removed you can now reinstall the rear wheels and torque wheel nuts to manufacturers spec.

15) Jack up vehicle, remove safety jack stands.

16) Remove wheel blocks from the front wheels.

17) Fill out warranty card and send to SuperSprings.

18) Enjoy the ride.



Important Notice.

- 1) For easy installation please read instructions completely first and have all necessary tools available.
- 2) We recommend that this installation be done by a professional or persons with sound mechanical knowledge.
- 3) SumoSprings are designed to work with the original factory springs only. If they have been replaced with aftermarket springs then please consult with Supersprings International.
- 4) These instructions are meant as a guide for the installation of SumoSprings. SuperSprings International assumes no liability for the actual installation process. Installers should apply common automotive safety practices when raising, lowering and working on vehicles.
- 5) SumoSprings are designed to enhance the vehicles load carrying performance and road handling however it does not authorize (or recommend) loading beyond the manufacturer's GVWR specifications.
- 6) For technical support contact SuperSprings International.

To prevent damage to the vehicle and to ensure safety, do not exceed the maximum load recommended by the vehicles manufacturer (GVWR).