

# SumoSprings Rear

Ford F250/F350 Super Duty, 1999-2010, 2x4, 4x4  
SSR-101-40-2 ~ SSR-101-47-2  
Installation Instructions

Passenger side (driver's side similar)

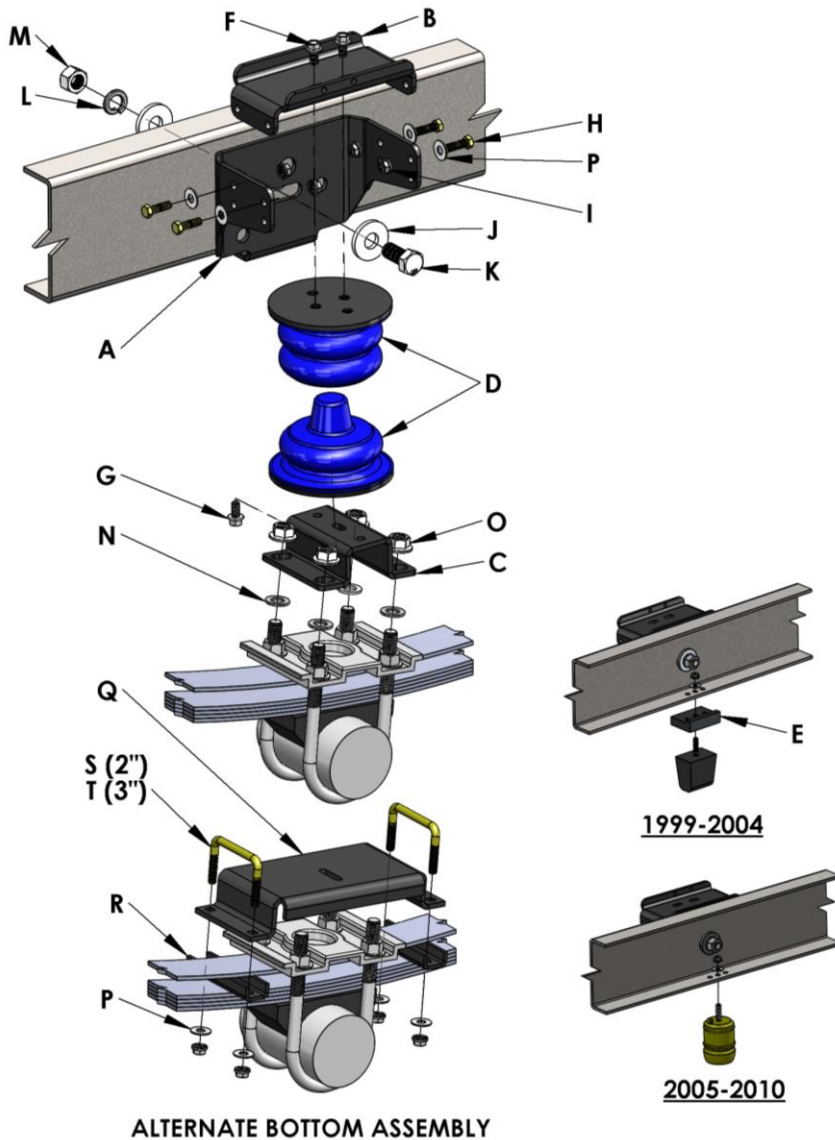

## Parts List

Item	Part #	Description	Quant.
A	512006	Frame bracket	2
B	512007	Upper bracket	2
C	512005	Lower bracket	2
D	511418	Sumo Rebel Black -47	2
	511419	Sumo Rebel Blue -40	2
E	512100	Bump stop spacer	2
F/G	512207	3/8-16x 3/4" serrated flange hex bolt	6
H	512223	3/8-16x1 1/4" hex head bolt	8
I	512209	3/8-16 flange hex nut	8
J	512204	3/4" fender washer	4
K	512203	3/4-16x1 3/4" hex head bolt	2
L	512205	3/4" lock washer	2
M	512206	3/4-16 hex nut	2
N	512202	16mm flat washer	8
O	512201	16mm serrated flange nut	8
P	512244	5/16" USS flat washers	16
Q	512048	Ford SD alt. lower bracket	2
R	512047	Lower u-straps	4
S	512254	3/8" u-bolt 3"x2"	4
T	512255	3/8" u-bolt 3"x5"	4
U	512234	3/8-16 top lock nut	8

## **Tool List**

<i>Floor Jack</i>	<i>1</i>
<i>Jack stands</i>	<i>2</i>
<i>Wheel blocks</i>	<i>4</i>
<i>24 mm wrench (15/16")</i>	<i>1</i>
<i>9/16" wrench</i>	<i>2</i>
<i>1- 1/8" wrench</i>	<i>1</i>
<i>1-1/8" socket and ratchet</i>	<i>1</i>

## **Installation Instructions**

### **Vehicle models 2005 and up.**

- 1) Park vehicle on level hard surface. Place wheel blocks in front and behind the front wheels to prevent rolling. Observe all safety precautions and wear safety glasses.
- 2) Raise the rear of the vehicle allowing the axle to hang free and rest the frame on the safety jack stands rated for the weight of the vehicle. Removal of the rear wheels is optional.
- 3) Remove the factory jounce bumpers from the underside of the frame and set aside for later re-installation.
- 4) Remove the pre-assembled upper bracket assembly – upper bracket (Item B)/frame bracket (Item A)/Sumo spring upper (Item D) assembly from the box. Attach the assembly to the bottom of the frame rail using the factory jounce bumper and nut utilizing the rear hole on the frame bracket and inserting the metal tab into the centre hole. Torque the attaching nut to 30 foot pounds.
- 5) Secure the frame bracket to the side of the chassis frame utilizing the 3/4-16 x 1 3/4" hex bolt (Item K), two 3/4" fender washers (Item J), one 3/4" lock washer (Item L) and one 3/4" hex nut (Item M), already loosely attached to the frame bracket, through the slotted hole in the frame. Tighten to 295 foot pounds of torque.
- 6) Remove the pre-assembled lower bracket assembly - lower bracket (Item C) and Sumospring lower (Item D). Place four 16mm flat washers (Item N) on to the upturned factory u-bolts allowing them to rest on the factory u-bolt nuts. Then place the lower bracket assembly onto the four upturned factory u-bolts and resting on the previously placed washers (Item N). Ensure that the deeper leg of the Lower bracket (Item C) is to the front of the assembly.
- 7) At this stage ensure that the upper bracket assembly and lower bracket assembly are aligned. If not you will need to loosen the 3/8-16 x 3/4" serrated flange bolts (Item F and/or G) to get alignment correct and then re-tighten these bolts to 30 foot pounds.
- 8) Attach 16mm serrated flange nuts (Item O) to the upturned factory u-bolts firmly attaching the lower bracket to the factory u-bolts.
- 9) Repeat steps three through eight on the other side of the vehicle.
- 10) If rear wheels were removed you can now reinstall the rear wheels and torque wheel nuts to manufacturers spec.
- 11) Jack up vehicle, remove safety jack stands.
- 12) Remove wheel blocks from the front wheels.
- 13) Fill out warranty card and send to SuperSprings. The warranty card is an attached document.

### **Alternative bottom bracket assembly.**

On occasion the factory u-bolts do not have sufficient length protruding through the top of the factory spring-plate to accommodate the Lower Bracket (Item c). In this case the alternative bottom bracket assembly is used as shown in page 1 above. In this case replace step 6, 7 and 8 above with steps 1, 2 and 3 below then continue steps 9 through 13 above.

1. Replace the Lower Bracket (Item C) to the bottom of the Sumospring in step 6 above and use the Alternate Lower Bracket (Item Q) and attach in the same way using a 3/8-16 x 3/4" serrated flange hex bolt (Item G). Once properly aligned torque the nuts to 30 foot pounds.
2. Where the truck is fitted with the top factory overload spring then the alternate lower bracket (Item Q) is attached to the overload leaf using two 3/8" u-bolts 3"x2" (Item S) and two lower u-straps (Item R). The u-bolts are secured using eight 3/8" USS flat washers (Item P) and eight 3/8-16 flanged hex nuts (Item I).
3. Where the truck is not fitted with the top factory overload spring then the alternate lower bracket (Item Q) is attached to the main spring-pack in a similar way to step 2 above except that instead of using the shorter u-bolts we use the longer 3/8" u-bolts 3"x 5" (Item T).

### ***Vehicle models 1999 through 2004.***

Installation is as for vehicles 2005 through 2010 with the exception that the convoy clip must be removed between step 3 and step 4. When reinstalling the factory bump-stop in step 4 the Bump-stop spacer (Item E) will be incorporated to account for the removed convoy clip.

### **Important Notice.**

- 1) For easy installation please read instructions completely first and have all necessary tools available.
- 2) We recommend that this installation be done by a professional or persons with sound mechanical knowledge.
- 3) SumoSprings are designed to work with the original factory springs only.
- 4) These instructions are meant as a guide for the installation of SumoSprings. SuperSprings International assumes no liability for the actual installation process. Installers should apply common automotive safety practices when raising, lowering and working on vehicles.
- 5) SumoSprings are designed to enhance the vehicles load carrying performance and road handling however it does not authorize (or recommend) loading beyond the manufacturer's GVWR specifications.

***To prevent damage to the vehicle and to ensure safety, do not exceed the maximum load recommended by the vehicles manufacturer (GVWR).***

# SumoSprings Rear

Suspension Enhancement  
FORD F-250/350 Super Duty [1999-2010]

No Fifth Wheel

SumoSprings SSR-101-40-1 ~ SSR-101-40-2  
SSR-101-47-2

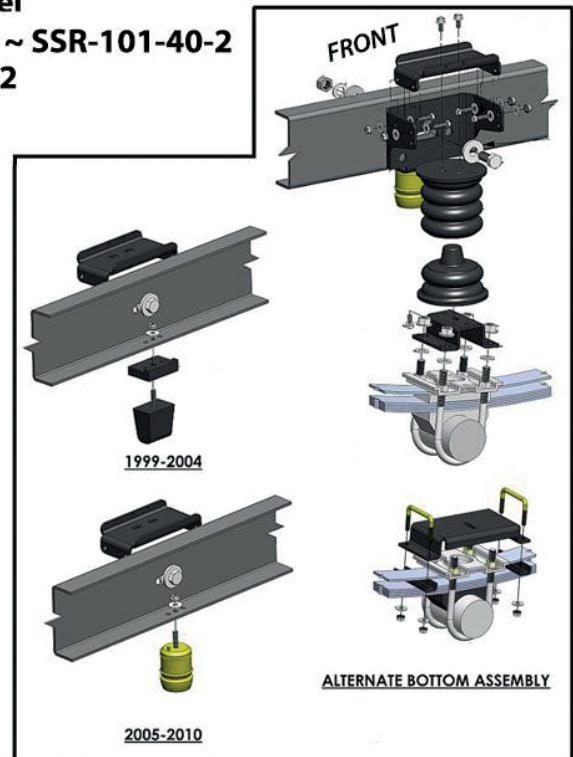

**Installation**

**Passenger Side**



**Typical SSR-101 installation with standard lower bracket**