

SuperSprings®

Dodge Ram 1500 (2009-Present)

Replacement Rear Coils

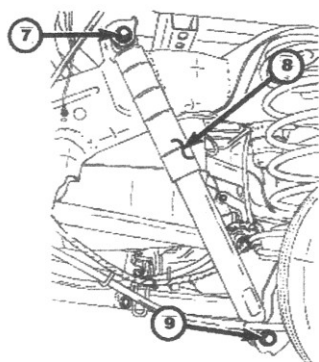
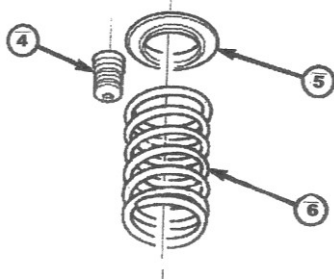
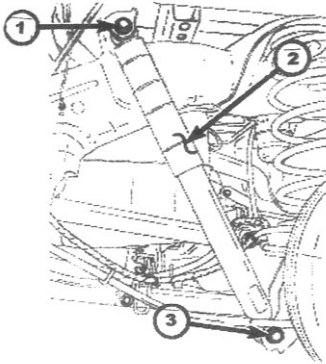

Installation Instructions

1. Park the vehicle on a solid level surface and chock the front wheels by placing blocks in front and rear of the wheels to prevent rolling.
2. Raise the rear of the vehicle by the axle using a platform jack rated for the vehicle weight until the tires are at least ten inches (10") off the surface.
3. Place jack stands rated for the vehicle weight under the frame in front of the rear axle. Place an additional jack stand under the axle on the left side.
4. Remove the right lower shock absorber bolt and nut show in the illustration (3).
5. Carefully lower the jack and avoid putting stress on the flexible brake or ABS lines. Tilt the axle to remove the spring (6) and insulator (5) from the vehicle.
6. Position the SuperCoil and insulator (5) on the axle and align into the upper spring seat while using the jack to raise the rear axle fully.
7. Install the shock absorber lower bolt and nut (9) which were removed in Step 4 and finger tighten only. The weight of the vehicle must be on the ground to torque the bolts.
8. Repeat Steps 4-7 for the left side.
9. Raise the vehicle and remove the jack stands under the axle and the vehicle frame.
10. Carefully lower vehicle to the surface.
11. With the weight of the vehicle fully on the surface, torque the lower shock absorber bolt and nut to 136 N.m or 100.5 ft. lbs.
12. Remove the blocks that chocked the front wheels.