



**SUPERLIFT® 2.5" LIFT KIT FOR 2007-2014
JEEP WRANGLER (JK) 4WD AND 2WD
INSTALLATION INSTRUCTIONS**

INTRODUCTION

Installation requires a professional mechanic. Prior to beginning, inspect the vehicles steering, drive-line, and brake systems, paying close attention to the suspension link arms and bushings, stabilizer bars and bushings, tie rod ends, pitman arm, ball joints and wheel bearings. Also check the steering sector-to-frame and all suspension-to-frame attaching points for stress cracks. The overall vehicle must be in excellent working condition; repair or replace all worn parts.

Read instructions several times before starting. Be sure you have all needed parts and know where they install. Read each step completely as you go.

NOTES:

- Prior to beginning the installation, check all parts and hardware in the box with the parts list below. If you find a packaging error, contact Superlift® directly. Do not contact the dealer where the system was originally purchased. You will need the control number from each box when calling; this number is located at the bottom of the part number label and to the right of the bar code.
- A precision steering alignment, including the centering of the steering wheel, is required in order for the vehicle's Electronic Stability Program to function properly. Using "all laser" alignment equipment is recommended.
- For 35" tires, Superlift's optional compression travel dampener kit (Part # 5714) is recommended to prevent tire / fender scrub during extreme articulation.
- 2 Door Wranglers - Due to increased driveshaft operating angles and short shaft length, factory rear driveshaft life will be reduced. When replaced, Superlift suggests converting to a dual cardan style shaft. These shafts can be purchased at many driveshaft shops.
- An arrow on diagrams indicates which direction is toward the front of the vehicle.
- A foot-pound torque reading is given in parenthesis () after each appropriate fastener.
- Do not fabricate any components to gain additional suspension height.
- Prior to drilling or cutting, check behind the surface being worked on for any wires, lines, or hoses that could be damaged. After drilling, smooth any burrs and sharp edges.
- Paint or undercoat all exposed metal surfaces.
- Prior to attaching components, be sure all mating surfaces are free of grit, grease, excessive undercoating, etc.

- A factory service manual should be on hand for reference.
- Use the check-off box "☐" found at each step to help you keep your place. Two "☐☐" denotes that one check-off box is for the driver side and one is for the passenger side. Unless otherwise noted, always start with the driver side.

IMPORTANT TIRE / WHEEL and CLEARANCE DATA

- Maximum tire width for use on factory wheels is 10.50". Factory Wrangler wheels are 17" diameter x 7" wide with 6.25" backspacing. Minimum aftermarket wheel diameter is 17".
- For an 11.50" wide tire, use an 8" to 8.5" wide wheel with 3.25" to 4.75 backspacing. Ideal backspacing is 4.5". -- For a 12.50" wide tire, use an 8.5" to 9" wide wheel with 3.25" to 4.75" backspacing. Ideal backspacing is 4.75". With 12.50" wide tires, expect some rear tire scrub at the plastic inner fender liners during full travel / articulation while off-roading; this generates a slight sound, but no damage.
- Maximum tire diameter is 35". For adequate clearance of 35" tires during full travel / articulation while off-roading, minor body trimming is required at the front / lower corner of the rear fenderwell openings. The rear ends of factory Rubicon rock rails must also be trimmed; both trimming steps are detailed in these Instructions.

PARTS LIST ... The part number is stamped into each part or printed on an adhesive label. Identify each part and place the appropriate mounting hardware with it.

Step	Part Number	Qty.	Description	Qty.	New Attaching Hardware	Hardware Bag Number
7	01-580	2	coil spring, front 2.5"			
7 & 21	shock absorbers	4	hydraulic shock			
8	55-39-5704	1	front lower brake hose bracket driver side	1	1/2" Adel clamp	77-5709A
				2	1/4" x 3/4" bolt	
				2	1/4" SAE washer	
				2	1/4" nyloc nut	
8	55-40-5704	1	front lower brake hose bracket passenger side	1	1/2" Adel clamp	77-5709A
				2	1/4" x 3/4" bolt	
				2	1/4" SAE washer	
				2	1/4" nyloc nut	
9	55-01-5709	1	sway bar link bracket driver side	1	1/2" x 1-1/4" bolt	77-5709A
				1	1/2" SAE washer	
				1	1/2" nyloc nut	
9	55-02-5709	1	sway bar link bracket passenger side	1	1/2" x 1-1/4" bolt	77-5709A
				1	1/2" SAE washer	
				1	1/2" nyloc nut	
18	01-581	2	coil spring, rear 2.5" 4 door model only			
18	01-582	2	coil spring, rear 2.5" 2 door model only			
19	55-21-5704	1	bracket, brake hose relocation, driver side / rear	1	1/4" X 3/4" bolt	77-5709A
				1	1/4" SAE washer	
				1	1/4" nyloc nut	
				1	1/4" x 1/2" self-tapping bolt	
				1	1/4" Adel clamp	
20	55-22-5704	1	bracket, brake hose relocation, passenger side / rear	1	1/4" X 3/4" bolt	77-5709A
				1	1/4" SAE washer	
				1	1/4" nyloc nut	
				1	1/4" x 1/2" self-tapping bolt	
				1	1/4" Adel clamp	
29	55-03-5709	1	alignment cam plates	4		77-5709B

Kit Part Number 580			Kit Part Number 77-60424		
Part Number	Qty.	Description	Part Number	Qty.	Description
01-580	2	coil spring, 2.5" front	01-60424	1	straight wall poly bushing - 3/4"
Kit Part Number 581			Kit Part Number 77-5709A		
Part Number	Qty.	Description	Part Number	Qty.	Description
01-581	2	coil spring, 2.5" rear 4 door	12ADC	2	1/2" Adel clamp
Kit Part Number 582			12C5NN	2	1/2" nyloc nut
Part Number	Qty.	Description	12SW	2	1/2" SAE washer
01-582	2	coil spring, 2.5" rear 2 door	12X114C5CS	2	1/2" x 1-1/4" bolt
Kit Part Number 5709			14ADC	2	1/4" Adel clamp
Part Number	Qty.	Description	14C5NN	6	1/4" nyloc nut
01-582	2	coil spring, 2.5" rear 2 door	14SW	6	1/4" SAE washer
Kit Part Number 5709			14X12STB	2	1/4" x 1/2" self-tapping bolt
Part Number	Qty.	Description	14X34C5CS	6	1/4" x 3/4" bolt
01-85290	2	shock absorber, front	Kit Part Number 77-5709B		
01-85139	2	shock absorber, rear	Part Number	Qty.	Description
77-87033	1	shock hardware bag	55-03-5709	4	alignment cam plates
77-5709A	1	hardware bag	55-21-5704	1	brake line bracket, rear driver upper
77-5709B	1	brake line bracket bag	55-22-5704	1	brake line bracket, rear passenger upper
Kit Part Number 77-87033			55-39-5704	1	brake line bracket, front driver lower
Part Number	Qty.	Description	55-40-5704	1	brake line bracket, front passenger lower
01-60418	4	hourglass poly bushing - 5/8"	Kit Part Number 77-87033		
24-5704	4	sleeve - 0.75" x 0.5" x 1.535"	Part Number	Qty.	Description
141991	2	stem washer pack	01-60418	4	hourglass poly bushing - 5/8"
01-60471	4	stem bushing half - large	24-5704	4	sleeve - 0.75" x 0.5" x 1.535"
38F5N	2	3/8" fine thread nut	141991	2	stem washer pack
77-60424	4	shock hardware bag	01-60471	4	stem bushing half - large
			38F5N	2	3/8" fine thread nut
			77-60424	4	shock hardware bag

TOOLS REQUIRED:

Drill			Standard Sockets	3/8" drive	3/8"
Torque Wrench					7/16"
Pry Bar					1/2"
Grinder					3/4"
File					
Cut-Off Wheel			Metric Wrenches	16mm	
				18mm	
Ratchets	3/8" drive			21mm	
	1/2" drive				
			Standard Wrenches	7/16"	
Extensions	3/8" drive	12" long		9/16"	
				3/4"	
Swivel	1/2" drive				
			Drill Bits	7/32"	
Metric Sockets	3/8" drive	10mm		9/32"	
		15mm			
		16mm			
	1/2" drive	18mm			
		21mm			

FRONT DISASSEMBLY

NOTE: Save all factory components and hardware for reuse, unless noted.

1) PREPARE VEHICLE...

- Place vehicle in neutral. Raise front of vehicle with a jack and secure a jack stand beneath each frame rail, behind the front / lower link arms. Ease the frame down onto the stands, place transmission in low gear or "park", and chock rear tires. Remove front tires.
- Position a jack so that it supports, but does not raise, the front axle.

2) TRACK BAR...

- Remove the bolt securing the front track bar-to-axle.

3) STABILIZER BAR LINKS and SHOCK ABSORBERS...

- Disconnect the front stabilizer bar links at the axle.
- Remove and discard the shock absorbers.

4) BRAKE HOSES, WIRING, and AXLE VENT HOSE...

- Detach the factory brake hose bracket (one per side) at the frame. This bracket holds the connection between the rubber brake hose and the metal brake line.

NOTE: The following steps provide adequate wiring / vent hose length to accommodate additional suspension extension travel:

- The upper end of the axle vent hose is clipped to the left side coil tower. Leave the hose attached to frame; simply pull down approximately 3" of hose.
- On Rubicon models, the wiring loom for the locking differential is attached to the axle-to-frame upper link. Remove and discard the clip.

4A) SOME 2010 and ALL 2011 and NEWER YEAR MODELS ONLY...

- [Illustration 1] Carefully pry the factory brake line bracket from the rubber hose. **DO NOT DAMAGE THE HOSE IN THE PROCESS.** If the hose is damaged it **MUST** be replaced.

5) DRIVESHAFT...

- Unbolt the front driveshaft at the front axle then tie it up and out of the way. Do not let the shaft "hang"; this risks pinching / damaging the grease boot at the transfer case end.

6) AXLE LINK ARMS and COIL SPRINGS...

- Loosen, but do not remove, the upper and lower link arm bolts at the axle and frame.

Illustration 1

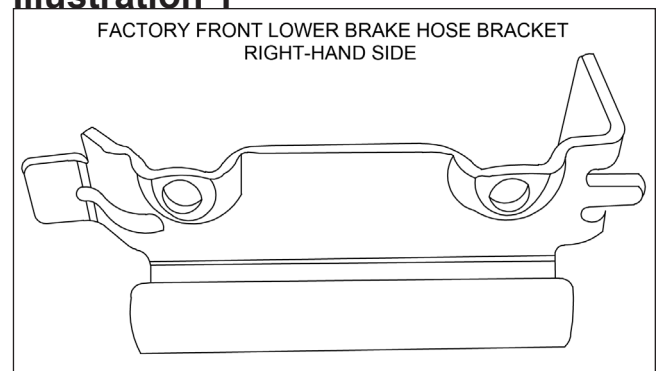

- Lower the axle enough to facilitate removing the front coil springs. Remove the coil springs.

FRONT ASSEMBLY

7) COIL SPRINGS and SHOCK ABSORBERS...

NOTE: Perform step 7 one side at a time.

- Be sure the factory rubber isolators are still in place inside the upper coil tower.
- Insert the coil spring into the upper tower followed by the lower seat. Be sure that the coils are indexed so they seat properly then raise the axle enough to hold the coil springs in place.
- [Illustration 2] Install shock absorber. Tighten the upper hardware until bushings swell slightly. Install the lower shock bolts, but do not tighten at this time. Apply Superlift decals. After the shock absorber installation is complete, the jack can be lowered and relocated to allow installation on the opposite side.

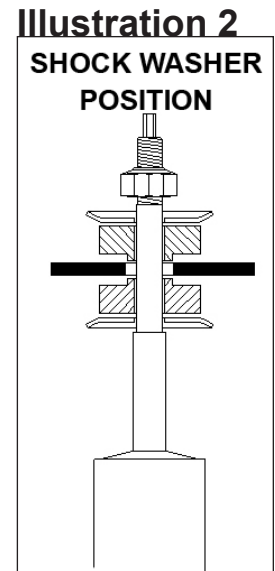

8) BRAKE HOSES...

- [Illustration 3] Place the new lower brake hose bracket (#55-39-5704 left-hand side; #55-40-5704 right-hand side) on the axle using the supplied 1/4" x 3/4" bolt, washer, and Nyloc nut. (76 in-lb)

- Position the adel clamp on the brake hose, then fasten the clamp to the front of the new Superlift bracket using the supplied 1/4" x 3/4" bolt, washer, and Nyloc nut. The steering must be cycled at this point to make sure that there is enough slack in the brake hose when the steering wheel is at full lock. If there is not adequate hose at a full lock turn, loosen the Adel clamp bolt and adjust the hose as needed.

- Attach the ABS line to the rear of the new Superlift bracket using the factory clips. Reattach upper brake line bracket.

9) STABILIZER BAR LINK BRACKET...

- [Illustration 4 and 5] Attach the stabilizer bar link bracket (#55-01-5709 left-hand side; #55-02-5709 right-hand side) to the outside of the original stabilizer bar link axle tab using the supplied 1/2" x 1-1/4" bolt, washer, and Nyloc nut (75).

- Re-attach the factory stabilizer bar link to the new Superlift bracket reusing the factory hardware.

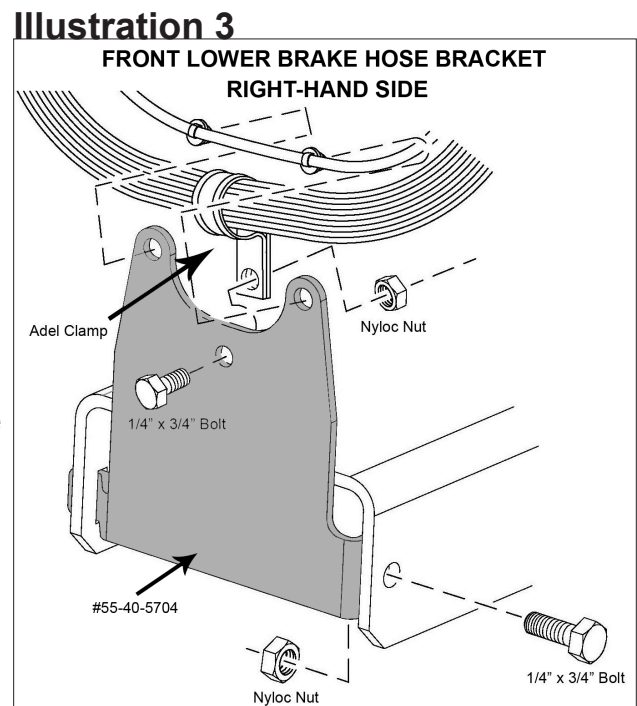

(75)

10) FRONT DRIVESHAFT...

Connect the front driveshaft-to-axle using the factory hardware (81).

11) TIRES / WHEELS...

[Illustration 6] Tighten the lug nuts (115) in the sequence shown.

WARNING: When the tires / wheels are installed, always check for and remove any corrosion, dirt, or foreign material on the wheel mounting surface, or anything that contacts the wheel mounting surface (hub, rotor, etc.). Installing wheels without the proper metal-to-metal contact at the wheel mounting surfaces can cause the lug nuts to loosen and the wheel to come off while the vehicle is in motion.

WARNING: Retighten lug nuts at 500 miles after any wheel change, or anytime the lug nuts are loosened. Failure to do so could cause wheels to come off while vehicle is in motion.

12) INITIAL CLEARANCE CHECK, FRONT...

With the vehicle still on jack stands, and the suspension "hanging" at full extension travel, cycle steering lock-to-lock and check all components for proper operation and clearances. Pay special attention to the clearance between the tires / wheels and brake hoses, wiring, driveshaft-to-crossmember, etc.

Lower vehicle to the . Final tightening and adjustments to the front suspension installation will take place once rear lift is completed.

REAR DISASSEMBLY**13) PREPARE VEHICLE...**

Place vehicle in neutral. Raise rear of vehicle with a jack and secure a jack stand beneath each frame rail, just ahead of the rear / lower link arms. Ease the frame down onto the stands, place transmission in low gear or "park", and chock front tires. Remove rear tires.

Position a jack so that it supports, but does not raise, the rear axle.

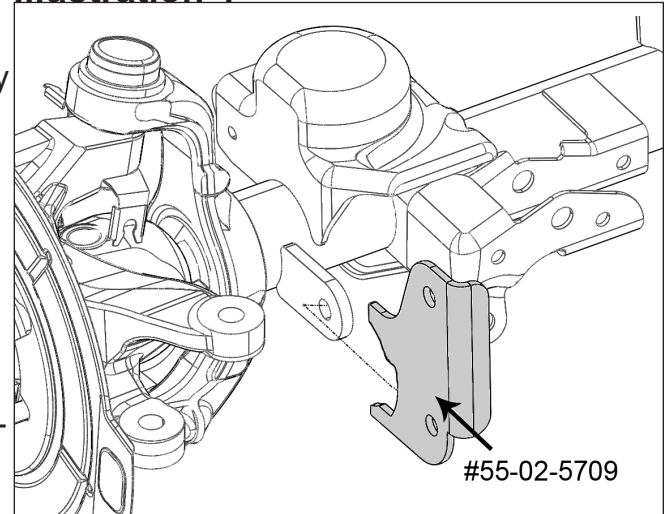
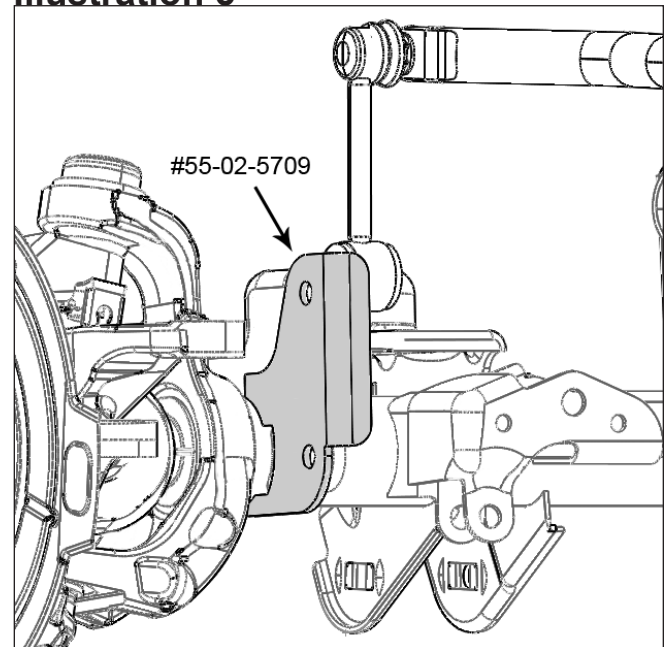
Illustration 4**Illustration 5****Illustration 6**

LUG NUT TORQUE SEQUENCE
Follow the pattern shown to torque the lug nuts.

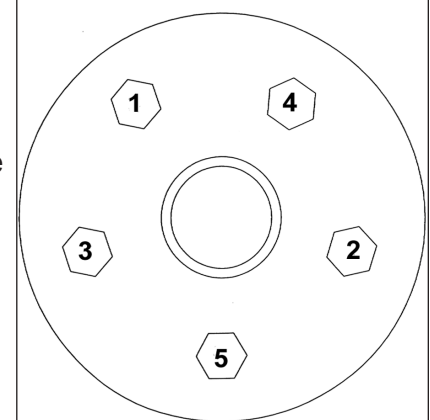

14) TRACK BAR and LINK ARMS...

- Disconnect the factory track bar from the axle and loosen the frame attachment point.
- Loosen, do not remove, the bolts securing both lower link arms to the axle and frame.
- Loosen, do not remove, the bolts securing both upper link arms to the axle and frame.

15) BRAKE HOSES and WHEEL SPEED SENSOR WIRES...

- Detach the factory brake hose bracket at the frame. This bracket holds the connection between the rubber brake hose and the metal brake line.
- Located on both the left and right side upper link arm mount there are two clips that retain the wheel speed sensor wires. Disconnect the forward-most clip from the arm mount.

16) STABILIZER BAR LINKS and SHOCK ABSORBERS...

- Disconnect the rear stabilizer bar links.
- Remove and discard the factory rear shock absorbers.

17) COIL SPRINGS...

- Lower the axle just enough to facilitate removing the coil springs. The driveshaft has a rubber boot on the transfer case end. If the axle is lowered too much, boot bind / damage may occur.

REAR ASSEMBLY**18) COIL SPRINGS...**

- Install the new coil springs. Rotate the coils so that they seat properly in the coil buckets then raise the axle enough to seat the springs.

19) STABILIZER BAR LINKS and SHOCK ABSORBERS...

- Reconnect the stabilizer bar links using the factory hardware. Tighten (75).
- Install shocks with the body of the shock cylinder at the bottom, using the factory hardware. Do not tighten at this time. Apply Superlift decals.

20) BRAKE HOSE and LINE RELOCATION, LEFT-HAND SIDE...

- [Illustration 7] A plastic frame clip attaches the metal brake line-to-frame; remove and discard this clip.

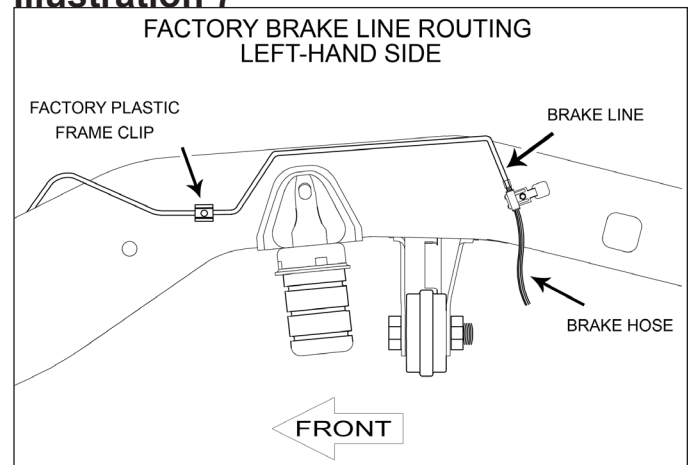
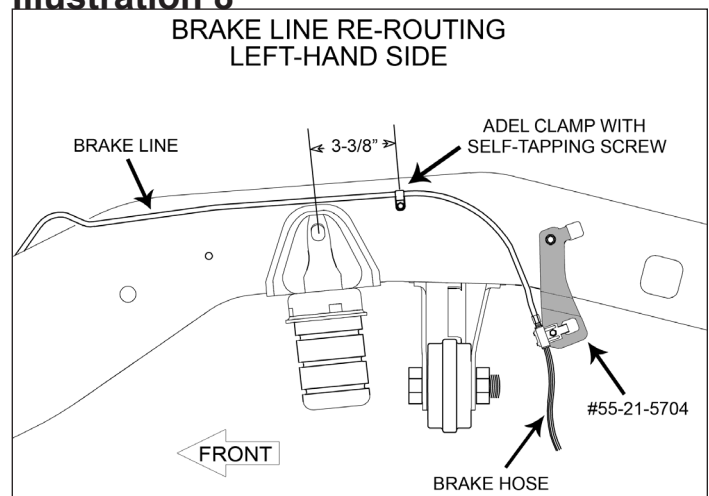
Illustration 7**Illustration 8**

□ Attach the left-hand side rear brake hose relocation bracket (#55-21-5704) to the factory frame location using the factory hardware. Be sure the bracket's alignment tab engages with the hole in the frame. Tighten (95 in-lb).

□ Attach the brake hose-to-bracket using the supplied 1/4" x 3/4" bolt, washer and Nyloc nut. Install bolt from the outside, place the washer on the nut side then tighten (95 in-lb).

□ [Illustration 8] Carefully re-form the metal line so that it runs along the upper edge of the frame, as shown...use extreme care, the line will kink / crimp easily. The supplied Adel clamp and self-tapping bolt will capture the front end of the metal line. Measure 1-3/8" down from the top of the frame rail, and 3-3/8" rearward of the compression travel dampener mount's centerline. At this point, drill a 7/32" pilot hole for the self-tapping screw.

□ Capture the metal line with the Adel clamp then attach clamp-to-frame using the self-tapping screw.

NOTE: The goal is no line-to-frame contact at any point; this prevents line and potential brake failure. Thoroughly re-check the product for line-to-frame contact. This re-routing also prevents potential line contact with the stabilizer bar links during suspension articulation.

21) BRAKE HOSE and LINE RELOCATION, RIGHT HAND SIDE...

□ [Illustration 9] Carefully detach the metal brake line from the plastic frame clip. Now carefully pry the frame clip from the frame; the clip will be relocated and reused.

□ Attach the rear brake hose relocation bracket (#55-22-5704) to the factory frame location using the factory hardware. Be sure the bracket's alignment tab engages with the hole in the frame. Tighten (95 in-lb).

□ Attach the brake hose-to-bracket using the supplied 1/4" x 3/4" bolt, washer and Nyloc nut. Install bolt from the outside, place the washer on the nut side then tighten (95 in-lb).

□ [Illustration 10] The plastic frame clip, removed in the previous step, is relocated to between the track bar mount and compression travel dampener mount. Measure 1-3/8" down from the top of the frame rail and drill a 1/8" pilot hole then enlarge to 1/4" diameter. Now plug the plastic frame clip into the hole.

□ Carefully re-form the metal line so that it is captured by the relocated frame clip... use extreme care, the line will kink / crimp easily. Now continue to route the brake line forward, along the top of

Illustration 9

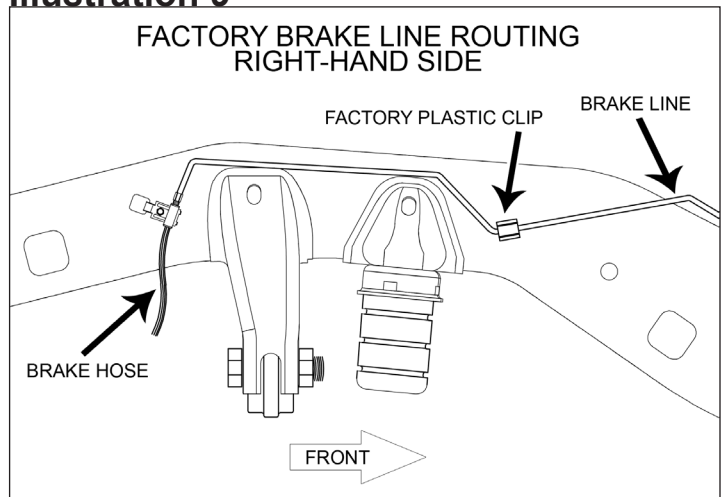
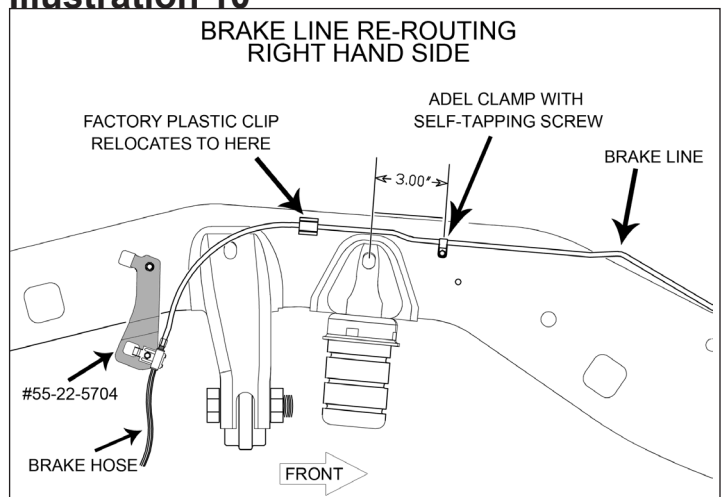

Illustration 10



the frame, as shown.

The supplied Adel clamp and self-tapping screw will capture the front end of the metal line. Measure 1-3/8" down from the top of the frame rail and 3" forward of the compression travel dampener mount's centerline. At this point, drill a 7/32" pilot hole for the self-tapping screw.

Capture the metal line with the Adel clamp then attach clamp-to-frame using the self-tapping screw.

NOTE: The goal is no line-to-frame contact at any point; this prevents line and potential brake failure. Thoroughly re-check the product for line-to-frame contact. This re-routing also prevents potential line contact with the stabilizer bar links during suspension articulation.

FINAL PROCEDURES

22) TIRES / WHEELS and REAR TRACK BAR...

Install the tires / wheels and torque lug nuts as per step 15.

Reconnect track bar using factory hardware. The bar will be tightened in a later step.

23) INITIAL CLEARANCE CHECK, REAR...

With the vehicle still on jack stands, and the suspension "hanging" at full extension travel, check all components for proper operation and clearances. Pay special attention to clearance between the tires / wheels and brake hoses, driveshaft, etc.

24) HARDWARE TIGHTENING SEQUENCE...

Front track bar, both ends (125).

Rear track bar, both ends (125).

Rear / lower link arm bolts-to-axle (125).

Rear / lower link arm bolts-to-frame (125).

Rear / upper link arm bolts-to-axle (125).

Rear / upper link arm bolts-to-frame (125).

Front / lower link arm bolts-to-axle(125).

Front / lower link arm bolts-to-frame (125).

Front / upper link arm bolts-to-axle (75).

Front / upper link arm bolts-to-frame (75).

All shock absorber eyes (56).

25) CENTER THE STEERING WHEEL...

NOTE: The steering wheel must be centered prior to driving the vehicle, or an Electronic Stability Program sensor may be activated resulting in a dash light and a warning chime that requires 20 plus ignition key cycles to clear.

- Start engine and turn the steering wheel so that tires point straight ahead. Loosen the nuts on the drag link adjustment sleeve then rotate the sleeve until steering wheel center is achieved.

NOTE: [Illustration 11] In order to achieve proper adjustment sleeve clamping force, clamp / bolt assemblies (found on the drag link and tie rod assemblies) must be positioned as shown. The open side of each clamp must align with the slot in the threaded adjustment sleeve. Improper positioning and bolt torque will promote linkage which may contribute to tire shimmy. Tighten clamp bolts (26). Also relay this information to the alignment shop that performs the alignment.

26) FINAL CLEARANCE and TORQUE CHECK...

- Cycle steering lock-to-lock and inspect the tires / wheels, and the steering, suspension, and brake systems for proper operation, tightness, and adequate clearance.

27) HEADLIGHTS...

- Adjust headlights to proper setting.

28) SUPERLIFT WARNING DECAL...

- The WARNING TO DRIVER decal installs on the inside / top / center of the windshield frame, just below the windshield frame's tie-down loop. Prior to installation, pre-clean the surface with the supplied alcohol cleaning pad.

29) ALIGNMENT...

- Realign vehicle to factory alignment. A precise alignment, including the centering of the steering wheel, is required in order for the vehicle's Electronic Stability Program to function properly. A laser alignment is recommended.

- If the vehicle requires an adjustment to the caster, Superlift has provided alignment plates that have three positions; -1.5° , 0° , $+1.5^\circ$.

- [Illustration 12] One side at a time, remove the bolt securing the lower link arm-to-axle then remove the knock-outs that change the opening from a square hole to a slotted hole. A special tool is available for this, or use a die grinder with a small cutting wheel. Install the alignment plates with the bolt hole in the desired position. Snug-up the bolts. (125)

Illustration 11

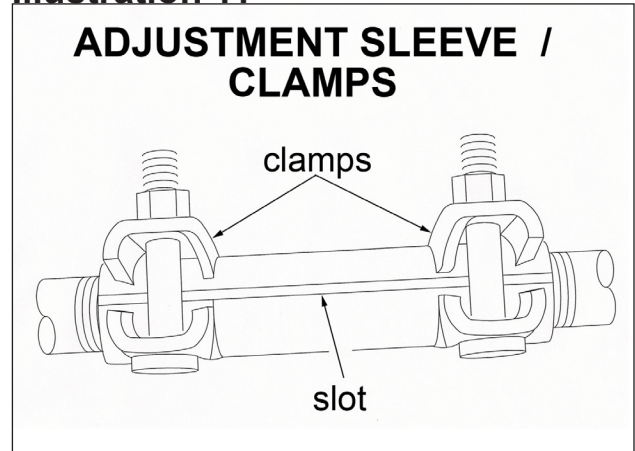
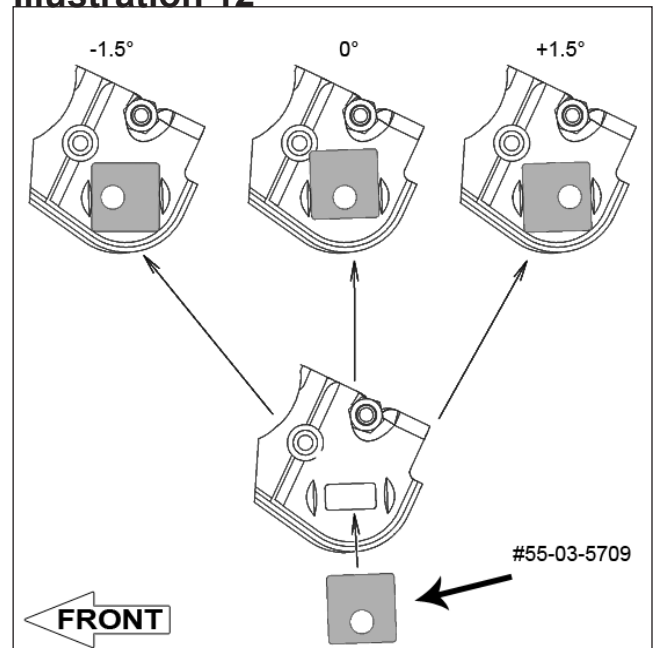

Illustration 12



30) TRIMMING REAR FENDERWELL OPENING...

□□ [Illustration 13] For adequate clearance of a 35" tire during full travel / articulation while off-roading the front / lower corner of the rear fenderwell opening will need to be trimmed on both sides of the vehicle. Measure from the bottom edge of the weld seam up 3" and to the front 2" and mark diagonal cut line.

□□ Once the fender is marked, using the appropriate cutting tool, cut along the line and remove the triangle shaped piece from the fender.

□□ After cutting clean the effected area with a grinder or and coat with paint.

31) TRIMMING FACTORY RUBICON ROCK RAILS...

NOTE: Disregard this step if vehicle is not equipped with factory Rubicon rock rails.

□□ [Illustration 14] For adequate clearance of a 35" tire during full travel / articulation while off-roading the rear of the factory Mopar rock rails need to be trimmed on both sides of the vehicle. Measure from the back of the rock rail to the front 2" and mark.

□□ Once the rail is marked, using the appropriate cutting tool, cut along the line and remove the 2" piece from the rock rail. Remove the plastic end cap from the cut piece.

□□ After cutting clean the effected area with a grinder or a and coat with paint. Reinstall the plastic end cap in end of the rock rail.

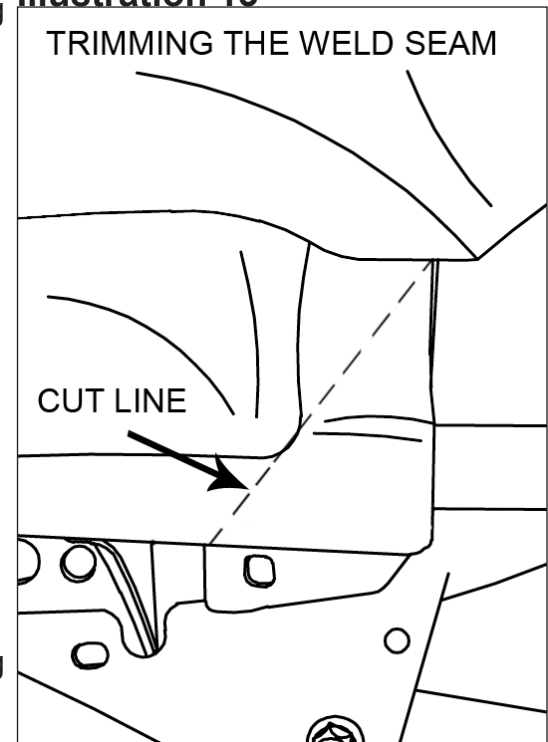
Illustration 13**Illustration 14**