



# **SUPERLIFT®**

## S U S P E N S I O N

### **SUPERLIFT 8" LIFT SYSTEM for 2014 1/2-ton Chevrolet Silverado and GMC Sierra 2WD and 4WD INSTALLATION INSTRUCTIONS**

#### **INTRODUCTION**

Installation requires a professional mechanic. Prior to beginning, inspect the vehicles steering, drive-line, and brake systems, paying close attention to the suspension link arms and bushings, anti-sway bars and bushings, tie rod ends, pitman arm, ball joints and wheel bearings. Also check the steering sector-to-frame and all suspension-to-frame attaching points for stress cracks. The overall vehicle must be in excellent working condition; repair or replace all worn parts.

**Read instructions several times before starting. Be sure you have all needed parts and know where they install. Read each step completely as you go.**

#### **NOTES:**

Prior to beginning the installation, check all parts and hardware in the box with the parts list below. If you find a packaging error, contact Superlift directly. Do not contact the dealer where the system was originally purchased. You will need the control number from each box when calling; this number is located at the bottom of the part number label and to the right of the bar code.

Do not fabricate any components to gain additional suspension height.

A special tool is required to disassemble / assemble the front struts. Other special tools are recommended to detach/attach the pitman/idler studs. Refer to the factory service manual.

Front end realignment is necessary.

An arrow on diagrams indicates which direction is toward the front of the vehicle.

A foot-pound torque reading is given in parenthesis ( ) after each appropriate fastener.

Prior to drilling or cutting, check behind the surface being worked on for any wires, lines, or hoses that could be damaged.

After drilling, file smooth any burrs and sharp edges.

Prior to operating a torch or saw, protect any heat-sensitive components located in the immediate area by covering them with a water-saturated cloth. Most undercoating are flammable but can be extinguished using a water-filled spray bottle. Have a spray bottle and an ABC rated fire extinguisher on hand.

Paint or undercoat all exposed metal surfaces.

Prior to attaching components, be sure all mating surfaces are free of grit, grease, undercoating, etc.

A factory service manual should be on hand for reference.

Use the check-off box "☐" found at each step to help you keep your place. Two "☐☐" denotes that one check-off box is for the driver side and one is for the passenger side. Unless otherwise noted, always start with the driver side.

### **IMPORTANT TIRE / WHEEL and CLEARANCE DATA**

Neither factory nor aftermarket 17" wheels will work with this lift system.

A 0.25" wheel spacer must be used if factory 18" or 20" wheels are used.

Maximum tire diameter and width for use on the factory 18" wheel (8.5" wide with 5.3" backspacing) is 34.0" x 10.50".

Maximum tire diameter and width for use on the factory 20" wheel (9.0" wide with 6.0" backspacing) is 35.0" x 12.50".

Recommended 18" wheel dimensions are 8.0" - 8.5" wide with 4.5" - 5.0" backspacing.  
Recommended tire for aftermarket 18" wheels is a 34.0" x 10.5"

Recommended 20" wheel dimensions are 8.0" - 9.5" wide with 4.5" - 5.75" backspacing.  
Recommended tire for aftermarket 20" wheels is a 35.0" x 12.5"

**PARTS LIST** ... The part number is stamped into each part or printed on an adhesive label. Identify each part and place the appropriate mounting hardware with it.

Kit Part Number 3570			Kit Part Number 3577		
Component	Qty	Component Description	Component	Qty	Component Description
66-01-3570	1	Knuckle, Dr Side 8" Chevy, AL OE LCA	413017	2	Urethane bump stop for strut
66-02-3570	1	Knuckle, PA Side 8" Chevy, AL OE LCA	01-85160	2	Shock Cylinder
77-3491	1	Hardware Bag	01-88150	2	Shock Cylinder-Gas Strut
77-3570	1	Hardware Bag	55-25-3570	1	Brkt, Front Crossmember
<b>OR</b>			55-07-3500	1	Brkt, Sway Bar Drop Driver
Kit Part Number 3574			55-08-3500	1	Brkt, Sway Bar Drop Passenger
Component	Qty	Component Description	55-12-3500	2	Front Strut Spacer for 8" kit
66-41-3570	1	Knuckle, Dr Side 8" Chevy, MS OE LCA	77-3451	1	Hardware Bag, Chevy Strut
66-42-3570	1	Knuckle, PA Side 8" Chevy, MS OE LCA	77-3486	1	Hardware Bag
77-3491	1	Hardware Bag	77-3488A	1	Hardware Bag
			77-3500	1	Hardware Bag
Kit Part Number 3580			77-80033	1	Shock Hardware Bag
Component	Qty	Component Description	Kit Part Number 3503		
55-03-3500	1	Brkt, Differential Drop - DR Side	Component	Qty	Component Description
55-04-3570	1	Brkt, Differential Drop - PA Side	059	2	Rear Lift Block 5"
55-16-3570	1	Brkt, Rear Crossmember	10542	4	U-Bolt, 9/16" X 2-1/2" X 14" Sq
55-09-3570	1	Brkt, Belly Pan - 4wd	01-2600	2	Add-A-Leaf, GM Pickup
66-15-3330	2	Mach, Axle Spacer	77-1509	1	9/16" Hi-Nut & Flat Washer Kit
77-3500-2	1	Hardware Bag	77-38500	1	3/8" Tie Bolt Hardware Bag
77-3572	1	Hardware Bag			

Kit Part Number 77-1509			Kit Part Number 77-3500		
Component	Qty	Component Description	Component	Qty	Component Description
1509	8	Hi-Nut, 9/16" Fine	13-3500	1	3/16" ID X 3/8" OD Tubing 8" Long, Vacuum
1559	8	9/16" U-Bolt Flat washer	16MDN	1	16mm x 1.5 Hex Die Nut
			716F85FN	6	Flange Nut, 7/16" Fine
Kit Part Number 77-3451			12-3492	2	sway bar link tube
Component	Qty	Component Description	38X12C5CS	2	Bolt, 3/8" X 12" coarse thread
38X212C5CS	4	Bolt, 3/8" X 2.5" Coarse	145098	3	washer hardware bag
38UW	8	Flat Washer, 3/8" USS	Kit Part Number 77-3500-2		
38C5NN	4	Nyloc Nut, 3/8" Coarse	Component	Qty	Component Description
10MNN	2	Nyloc Nut, 10mm X 1.5	58C8SN	2	Stover Nut, 5/8" Coarse
Kit Part Number 77-3482B			58SW	4	Flat Washer, 5/8" SAE
Component	Qty	Component Description	58X512C5CS	2	Bolt, 5/8" X 5-1/2" Coarse
01-2210	8	Poly Bush, T-Bar Sm. Eye	Kit Part Number 77-3570		
12-3370	4	Sleeve - 0.75" X 0.46875" X 2.625"	Component	Qty	Component Description
31-3480	2	7/16" Tab Nut	14MX2.0X50FB	2	14mm x 2.0 x 50mm flange head bolt
716C8SN	4	Stover Nut, 7/16" Coarse	12-3492	2	Sway Bar Link
716SW	12	Flat Washer, 7/16" SAE	38X12C5CS	2	Bolt, 3/8" x 12" Coarse
716X114C5CS	2	Bolt, 7/16 X 1-1/4 Coarse	145098	3	Bushing and Washer Pack
716X112C5CS	1	Bolt, 7/16 X 1-1/2 Coarse	Kit Part Number 77-3572		
716X334C5CS	4	Bolt, 7/16 X 3-3/4 Coarse	Component	Qty	Component Description
Kit Part Number 77-3486			10MFW	12	Washer, 10mm Flat
Component	Qty	Component Description	10MX1.5X70CS	12	Bolt, 10mm X 1.5 X 70mm
14C5NN	2	Nyloc Nut, 1/4" Coarse	12C8SN	2	Stover Nut, 1/2" Coarse
14X34C5CS	2	Bolt, 1/4" X 3/4" Coarse	12MLW	2	Lock Washer, 12mm
38X1C5CS	2	3/8" x 1" bolt, coarse thread	12MX1.75X30CS	2	Bolt, 12mm X 1.75 X 30mm
38SW	4	3/8" sae washer	12SW	4	Flat Washer, 1/2" SAE
38C5NN	2	3/8" nyloc nut	12X134C5CS	2	Bolt, 1/2" X 1-3/4" Coarse
55-09-3492	2	Brkt, Frt Brake line Dr	16-9690	1	3/16" ID X 3/8" OD Tubing 4" Long, Vacuum
Kit Part Number 77-3488A			17-9690	1	3/16" Vacuum Connector
Component	Qty	Component Description	58C8SN	2	Stover Nut, 5/8" Coarse
10MFW	8	Washer, 10mm Flat	58X134C5CS	2	Bolt, 5/8" x 1-3/4" Coarse
10MNN	4	Nyloc Nut, 10mm X 1.5	58SW	4	Flat Washer, 5/8" SAE
10MX1.5X25CS	4	Bolt, 10mm X 1.5 X 25mm	1555	2	5/8" U-Bolt Flat washer
1112CT	2	Cable Tie, 11-1/2" Black	38X1C5CS	4	Bolt, 3/8" X 1" Coarse
58C8SN	2	Stover Nut, 5/8" Coarse	38SW	8	Flat Washer, 3/8" SAE
58SW	4	Flat Washer, 5/8" SAE	38C5FN	4	Flange Nut, 3/8" Coarse
58X412C5CS	2	Bolt, 5/8" X 4-1/2" Coarse	Kit Part Number 77-38500		
Kit Part Number 77-3491			Component	Qty	Component Description
Component	Qty	Component Description	01-38500	2	Tie Bolt 3/8" X 5"
516X1STB	2	Bolt, 5/16" X 1" Self Tapping	38F5N	2	Std. Nut, 3/8" Fine
F470L	1	Thread Locker #27105	Kit Part Number 77-80033		
14MX2.0X50FB	4	Bolt, 14mm x 2.0 x 50mm Flange Head	Component	Qty	Component Description
			01-60418	4	Poly Bush, 3/4" X 1.44" Sm. Hourglass Eye
			34SW	4	Washer, 3/4" Flat Sae
			39-3480	4	Shock Sleeve, 0.750" OD x 0.563" ID x 1.68" L

Step	Component	Qty.	Component Description	Qty.	New Attaching Hardware	Hardware Bag Number
17	66-01-3570	1	Knuckle, Dr Side 8" Chevy, AL OE LCA	1	Bolt, 5/16" X 1" Self Tapping	77-3491
	or			0.5	Thread Locker #27105	
17	66-41-3570	1	Knuckle, Dr Side 8" Chevy, MS OE LCA	2	Bolt, 14mm x 2.0 x 50mm Flange Head	77-3570
17	66-02-3570	1	Knuckle, PA Side 8" Chevy, AL OE LCA	1	Bolt, 5/16" X 1" Self Tapping	77-3491
	or			0.5	Thread Locker #27105	
17	66-42-3570	1	Knuckle, Dr Side 8" Chevy, MS OE LCA	2	Bolt, 14mm x 2.0 x 50mm Flange Head	77-3570
10	55-03-3500	1	Brkt, Differential Drop - DR Side	2	Bolt, 1/2" X 1-3/4" Coarse	77-3572
				2	Bolt, 12mm X 1.75 X 30mm	
				2	Flat Washer, 1/2" SAE	
				2	Lock Washer, 12mm	
				2	Stover Nut, 1/2" Coarse	
10	55-04-3570	1	Brkt, Differential Drop - PA Side	1	3/16" ID X 3/8" OD Tubing 4" Long, Vacuum	77-3572
				1	3/16" Vacuum Connector	
				2	5/8" U-Bolt Flat washer	
				2	Stover Nut, 5/8" Coarse	
11	55-25-3570	1	Brkt, Front Crossmember	2	Bolt, 5/8" X 4-1/2" Coarse	77-3488A
				4	Flat Washer, 5/8" SAE	
				2	Stover Nut, 5/8" Coarse	
12	55-16-3570	1	Brkt, Rear Crossmember	2	Bolt, 5/8" X 5-1/2" Coarse	77-3500-2
				4	Flat Washer, 5/8" SAE	
				2	Stover Nut, 5/8" Coarse	
22	55-07-3500	1	Brkt, Sway Bar Drop Driver	2	Bolt, 10mm X 1.5 X 25mm	77-3488A
				2	Nyloc Nut, 10mm X 1.5	
				4	Washer, 10mm Flat	
22	55-08-3500	1	Brkt, Sway Bar Drop Passenger	2	Bolt, 10mm X 1.5 X 25mm	77-3488A
				2	Nyloc Nut, 10mm X 1.5	
				4	Washer, 10mm Flat	
40	12-3492	2	sway bar link	1	3/8" x 12" bolt, coarse thread	77-3570
				2	145098 washer bag	
13	55-09-3570	1	Brkt, Belly Pan - 4wd	4	Bolt, 3/8" X 1" Coarse	77-3572
				8	Flat Washer, 3/8" SAE	
				4	Flange Nut, 3/8" Coarse	
19	55-12-3500	2	Front Strut Spacer for 8" kit	3	Flange Nut, 7/16" Fine	77-3500
20	55-09-3492	2	Brkt, Frt Brake line	1	3/8" x 1" bolt, coarse thread	77-3486
				2	3/8" sae washer	
				1	3/8" nyloc nut	
				1	1/4" x 1" bolt, coarse thread	
				2	1/4" sae washer	
				1	1/4" nyloc nut	
18	66-15-3330	2	Mach, Axle Spacer	6	Bolt, 10mm X 1.5 X 70mm	77-3572
				6	Washer, 10mm Flat	
19	01-88150	2	Shock Cylinder-Gas Strut	2	Bolt, 3/8" X 2-1/2" Coarse	77-3451
				4	Flat Washer, 3/8" USS	
				1	Nyloc Nut, 10mm X 1.5	
				2	Nyloc Nut, 3/8" Coarse	
				1	Urethane bump stop for strut	
30	01-85160	2	Shock Cylinder	2	Poly Bush, 3/4" X 1.44" Sm. Hourglass Eye	77-80033
				2	Shock Sleeve, 0.750" OD x 0.563" ID x 1.68" L	
				2	Washer, 3/4" Flat Sae	
29	01-2600	2	Add-A-Leaf, GM Pickup	1	Tie Bolt 3/8" X 5"	77-38500
				1	Std. Nut, 3/8" Fine	
30	059	2	Rear Lift Block 5"	2	U-Bolt, 9/16" X 2-1/2" X 14" Sq	77-1509
				4	HI-Nut, 9/16" Fine	
				4	9/16" U-Bolt Flat washer	

# FRONT DISASSEMBLY

**NOTE:** Save all factory components and hardware for reuse, unless noted.

## 1) PREPARE VEHICLE...

Place vehicle in neutral. Raise front of vehicle with a jack and secure a jack stand beneath each frame rail, behind the lower control arms. Ease the frame down onto the stands, place transmission in low gear or "park", and chock rear tires. Remove front tires.

Disconnect the battery.

## 2) BRAKE CALIPERS...

Unbolt the brake hoses from the upper control arm.

Remove the two bolts securing the caliper bracket to the knuckle. It is not necessary to remove the caliper from the bracket. Leave the brake hose attached to the caliper, and using mechanic's wire, hang the calipers out of the way. Take precautions to ensure the brake hose isn't stretched or pinched.

Unplug the ABS wire from the connector located at the top of the frame rail and unclip the wire from the upper control arm.

Remove the torx bolt retaining the rotor to the hub assembly, remove the brake rotor, and set it aside.

## 3) AXLESHAFTS...

**NOTE:** For 2wd systems, proceed to the next step.

Remove any factory skid plates or shields that block access to front suspension components.

Remove the six bolts that attach the axlehaft to the CV flange on the differential.

## 4) TIE ROD ENDS...

Remove the nuts securing the tie rod ends to the knuckle. Using the appropriate puller tool, separate the tie rod end from the knuckle.

## 5) ANTI-SWAY BAR...

On each side, loosen and remove the bushings and hardware attaching the anti-sway bar link to the lower control arm and sway bar body.

Remove the bolts securing the anti-sway bar to the frame and remove the bar.

## 6) STRUT REMOVAL...

Mark the location of each strut (driver and passenger side) as well as the outermost stud of each strut for later reference during re-assembly.

Remove the two bolts securing the strut to the lower control arm, followed by the three nuts securing the strut to the frame. Remove the strut while taking precautions not to damage any other vehicle components.

## 7) CONTROL ARM / HUB ASSEMBLY...

**NOTE:** For 2wd systems, disregard steps for removal of the CV axleshafts.

- Mark the location of the CV axleshafts (driver and passenger side) for later reference during assembly.
- Remove the dust cap in the center of the wheel hub and then remove the nut securing the axle-shaft to the hub assembly (a 1-3/8" socket will fit). Slide the axleshaft towards the center of the vehicle to disengage it from the hub and remove the axleshaft from the vehicle.
- Support the control arm / hub assembly with a jack. Remove the upper ball joint nut and, using the appropriate puller tool, separate the upper control arm ball joint from the knuckle.
- Remove the nut securing the lower ball joint to the knuckle and, using the appropriate puller tool, separate the lower control arm ball joint from the knuckle. Set the knuckle, with the wheel bearing assembly still attached, aside.
- Remove the bolts securing the lower control arm to the frame and set the lower control arm aside.

## 8) DIFFERENTIAL...

**NOTE:** For 2wd systems, proceed to the next step.

- Remove the electrical plug and vent hose from the differential.
- Mark the driveshaft in relation to the differential yoke for reference during re-assembly. Unbolt the driveshaft from the differential and tie it up out of the way using mechanics wire.
- Support the differential housing with a jack.
- Remove and discard the factory rear crossmember.
- Remove the two differential mounting bolts on the driver side, followed by the nuts on the passenger side. With the help of an assistant, carefully lower the differential housing to the floor.

## 9) TRIMMING THE FRAME...

- [Illustration 1] On each side, trim the inside corners of the factory front crossmember enough to facilitate installing the (#55-15-3570) front crossmember. It is only necessary to square off the radius present in the factory crossmember. Test fit the "15" crossmember and trim accordingly.
- [Illustration 2] On the driver side rear lower control arm mount, measure over 1" from the center of the lower control arm mount hole. Mark the cut line all the way around the mount. Using a torch, plasma cutter, or similar tool, trim the driver side lower control arm bracket.
- [Illustration 3] Locate the rear lower control arm mount on the passenger side. The forward side lip of this bracket must be trimmed to allow for clearance of the differential. Measure outboard 1/2" from the edge of the outermost bolt hole and mark. Trim just above the lip to this mark as shown in the Illustration.

## FRONT ASSEMBLY

### 10) DIFFERENTIAL BRACKETS...

**NOTE:** For 2wd systems, proceed to the next step.

- [Illustration 4] Remove the factory passenger side “u” shaped differential bracket. Attach passenger side differential bracket (#55-04-3570) to the factory passenger side differential mount using the factory hardware, as shown. Tighten (75).
- Reattach the assembly to the factory location using the factory hardware. NOTE: the “fins” on the electronic power steering casing may make contact with the new differential bracket. If this occurs, unplug the cable from casing, then carefully remove some material from the casing using a grinder. Reconnect plug once complete.
- Note that the driver side differential bracket (#55-03-3500) has a taper in it; position the bracket so that the small end of the taper faces rearward (to match the taper of the passenger side bracket). Also note there is a hole in the center of the bracket that accommodates a tab in the center of the factory differential mount. Attach the “03” bracket to the factory mount using the supplied 12mm x 30mm bolts and 12mm lock washers. Do not tighten at this time.

- Using a jack, raise the differential into position and line up the mounting holes with the “03” and the studs on “04” drop brackets. Attach the differential on the driver side using the supplied 1/2” x 1-3/4” bolts, washers, and nuts. Do not tighten at this time.
- Attach the passenger side of the differential to the “04” bracket using the supplied washers, and Nyloc nuts. The extra-thick flat washers should be positioned under the nuts. Do not tighten at this time.
- Reconnect the differential wiring. Attach the supplied vent hose extension to the factory vent hose and reconnect it to the differential.

- Tighten the following hardware in sequence:

- 12mm differential hardware (87)
- 1/2” differential hardware (76)
- 5/8” differential hardware (150)

### 11) FRONT CROSSMEMBER...

- Attach the front crossmember (#55-25-3570) to the original lower control arm front leg mounting

#### Illustration 1

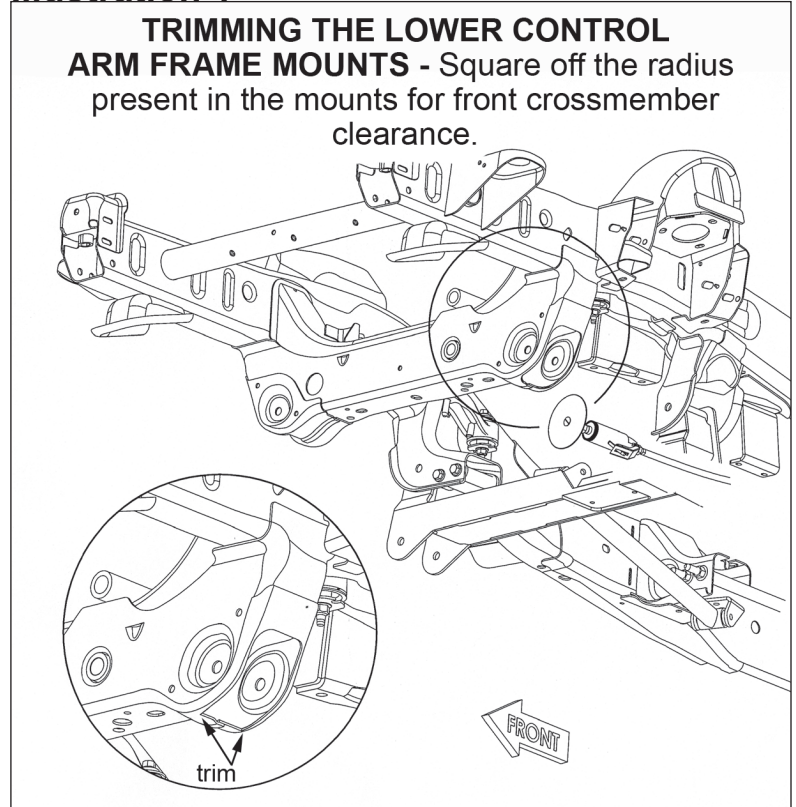

points on the frame using the supplied 5/8" x 4-1/2" bolts, washers, and nuts. The bolts should be installed from the front. Note that the crossmember should be positioned so that the mounting tab for the differential skid plate points rearward. Do not tighten at this time.

## 12) REAR CROSSMEMBER...

□ Attach the rear crossmember (#55-16-3570) to the original lower control arm rear leg mounting points on the frame using the supplied 5/8" x 5-1/2" bolts, washers, and nuts. The bolts should be installed from the front. Do not tighten at this time.

□ On the passenger side re-install the factory hardware through the factory crossmember hole and the Superlift crossmember (#55-16-3570). Do not tighten at this time.

## 13) BELLY PAN...

□ Attach the belly pan (#55-09-3570) to the mounting tabs on the front and rear crossmembers using the supplied 3/8" x 1" bolts, washers (at head and nut), and flange nuts. Tighten (30).

## 14) FASTENER TIGHTENING SEQUENCE...

□ Tighten the 5/8" crossmember hardware (154).

## 15) DRIVESHAFT...

**NOTE:** For 2wd systems, proceed to the next step.

□ Line up the front driveshaft with the differential yoke according to the marks made during removal and secure using the factory hardware. Tighten (18).

## 16) LOWER CONTROL ARMS...

□□ [Illustration 5 and Template 1 or 2 on last page] Template 1 is for all steel lower control arms. Template 2 is for all aluminum lower control arms. Cut out the supplied template attached to the end of this instruction form. Line up the template with the existing anti-sway bar link mounting hole as shown. Scribe the location of the new hole to be drilled (which should be inboard of the existing hole).

## Illustration 2

### TRIMMING THE DRIVER SIDE LCA MOUNT - Trim following the steps below.

1

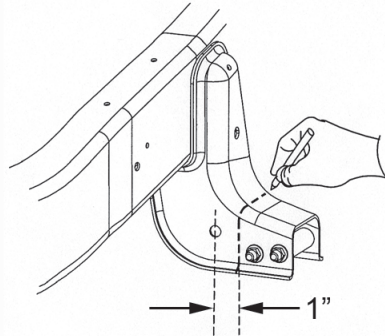

Measure 1" over from center of LCA hole.

2

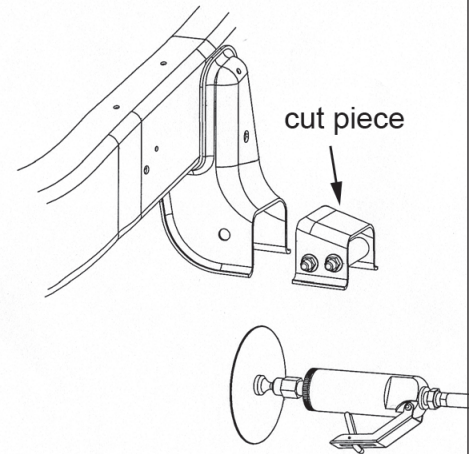

## Illustration 3

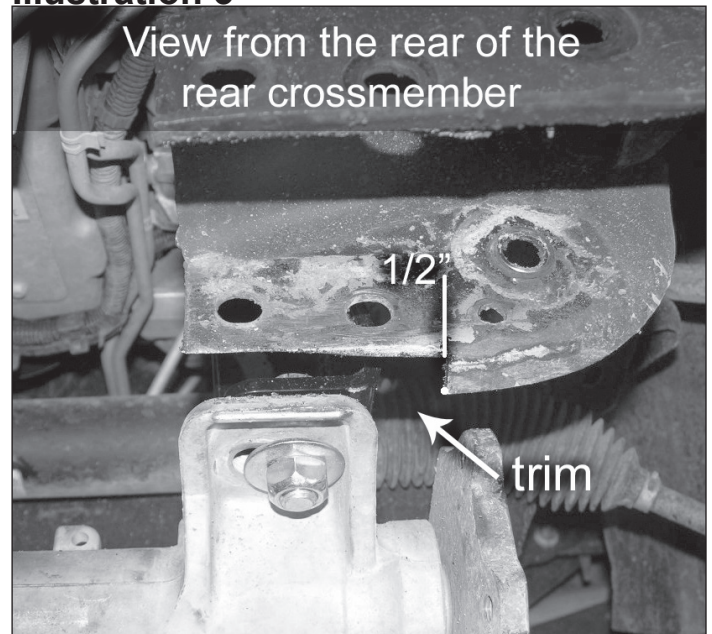



□□ Drill an 11/16" hole at the scribed location.

□□ Attach the lower control arm to the front and rear crossmembers using the factory hardware. The bolts should be installed from the front. Snug, but do not tighten the hardware at this time.

## 17) KNUCKLE ASSEMBLY AND INSTALLATION...

**NOTE:** Perform these steps on one knuckle at a time.

□□ Carefully note the orientation of the dust shield and wheel bearing assembly prior to removal. Remove the three bolts securing the wheel bearing assembly to the factory knuckle.

### Illustration 4

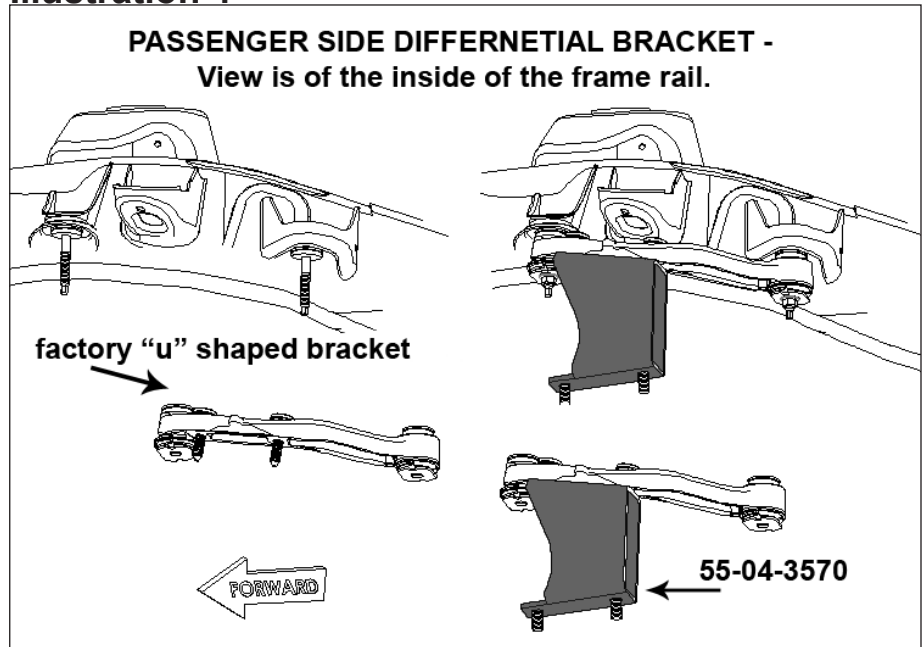

□□ [Illustration 6] Remove the dust shield and wheel bearing assembly from the factory knuckle. Now test-fit the dust shield on the new knuckle (#66-01-3570 driver side and #66-02-3570 passenger side; or #66-41-3570 driver side and #66-42-3570 passenger side). Mark the area of the dust shield to be trimmed as shown. Remove the dust shield and trim at the marked location using a cut-off wheel or similar tool.

□□ Install the bearing assembly and dust shield on the Superlift knuckles using the factory hardware. Be sure the orientation of the dust shield and bearing assembly matches original. Use the supplied thread-locking compound on the three factory fasteners

□□ Install the knuckle assembly and secure using the factory nuts. Tighten the upper nut (37) and lower nut (94).

□□ Check-fit the brake caliper to be sure enough material has been removed from the dust shield. If interference is evident, mark the area on the dust shield, remove the wheel bearing and dust shield from the knuckle, and trim until the necessary clearance is achieved.

□□ Tighten the three factory bearing assembly bolts (133).

## 18) AXLESHAFTS...

**NOTE:** For 2wd systems, proceed to the next step.

□□ Turn each knuckle so that the front of the knuckle is pointing outward. Position and install the axleshafts according the marks made during removal (Driver and Passenger). This is done by passing the differential end of the axleshaft in front of the differential housing and then sliding the shaft through the hub assembly. Secure the shaft with the factory nut and tighten (148-165). Reattach the dust cap.

□□ Position an axleshaft spacer (#66-15-3330) between the flange on the axleshaft and the flange on the differential and secure using the supplied 10mm x 70mm bolts and flat washers. Tighten (58).

## 19) REPLACEMENT STRUT ASSEMBLY AND INSTALLATION...

If installing King Coilovers by Superlift; install using separate instructions included in the King kit box then move to step 20.

**WARNING:** Extreme care must be taken during the following steps. The struts have a tremendous amount of energy stored in them and can cause serious injury or even death if an attempt is made to work on them without the proper tools. Disassembly / assembly of the struts can only be performed by a qualified professional with the special equipment designed for this task. If necessary, the struts can be taken to a shop with the proper equipment to have the necessary work performed.

**NOTE:** A factory service manual should be on hand for reference. Perform the strut assembly and installation one side at a time.

□□ Make careful note of the order and orientation of all the factory pieces for proper re-assembly, including the position of the upper studs in relation the large bar pin at the bottom of the strut. Place the strut assembly in a heavy-duty strut compressor and compress the coil spring enough to unload the strut cylinder. Remove the retaining nut on the upper shock mount and carefully remove the strut cylinder. The lower spring seat and foam compression stop should come out with the strut; if not, remove these items from the coil assembly.

□□ [Illustration 7] There is a metal cap with a light press fit on the body of the factory strut; tap the cap off of the strut with a hammer. Remove the retaining ring and lower spring seat from the original strut and install them in the same order on the replacement strut (#01-88150). Take special note that the factory lower spacer has a groove machined into it; the snap ring on the strut should recess into

### Illustration 5

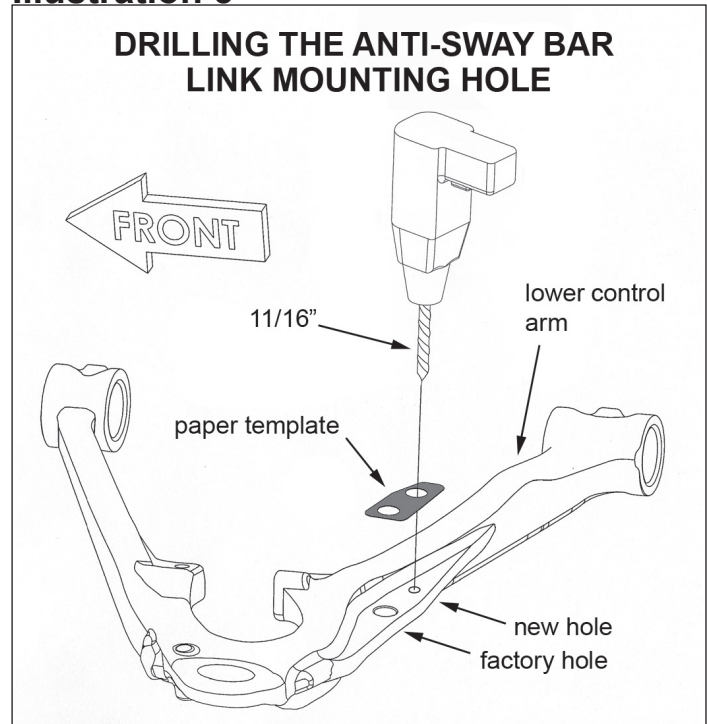

### Illustration 6

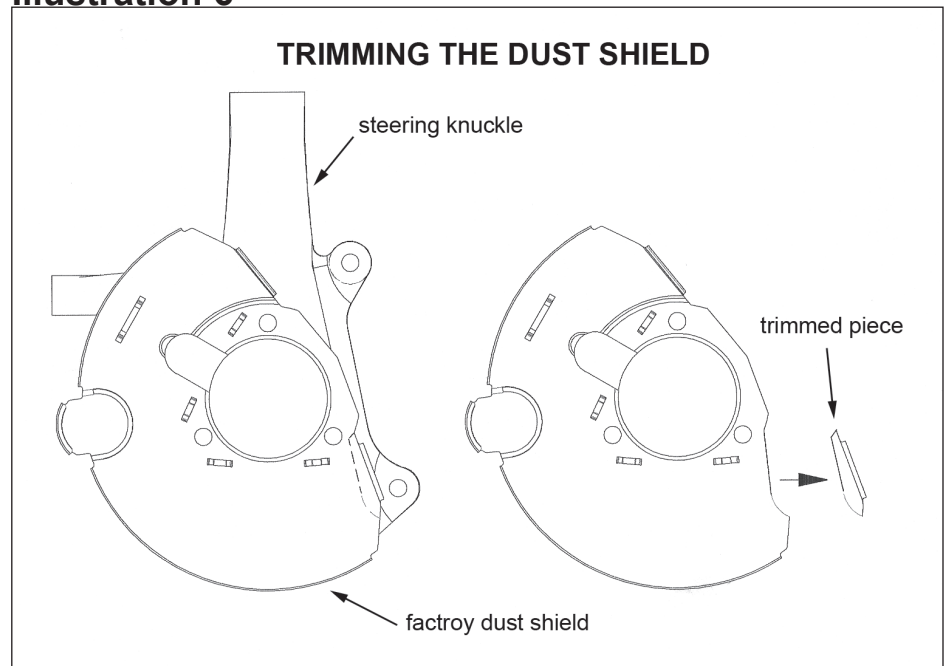

this groove.

□□ Place the supplied cone-shaped foam compression stop over the rod of the new strut with the narrow end facing down as shown. The original compression stop and washer will not be re-used and can be discarded. Please note that the original compression stop cup must be retained but must have the hole drilled out to 19/32" to fit over the new strut. The Superlift compression snubber slides freely along shaft of the strut and does not fit into the factory compression stop cup.

□□ Slide the new strut assembly into the coil spring and be sure all of the strut pieces are in the same orientation as they were originally (refer to the factory service manual). Torque the 10mm retaining nut (37) and carefully unload the strut.

□□ Place the new strut spacer (#55-12-3500) onto the strut and fasten using the factory hardware (37). **NOTE:** The top of the factory studs may need to be ground down for clearance.

□□ Slide the strut assembly through the lower control arm and rotate it to match the marks made during removal. Secure the upper end of the strut using the factory nuts. Do not tighten at this time.

□□ Attach the lower end of the strut to the lower control arm using the supplied 3/8" x 2-1/2" bolts, USS washers, and Nyloc nuts. Note that two washers should be used per bolt.

□□ Tighten the supplied nuts at the top (50) and the supplied 3/8" hardware at the bottom (30) of the strut.

## 20) BRAKE CALIPERS AND ABS WIRING...

□□ Install the brake rotor and secure it using the factory Torx bolt and tighten (106 in-lbs).

□□ Remove the factory brake line bracket from the frame located on the rearward side of the upper control arm mount. {13mm}

□□ Attach the brake line relocation bracket (55-09-3492) to the factory brake line location on the frame. Secure using the factory hardware in the factory hole and use the supplied 3/8" x 3/4" bolt, washer, and nyloc nut in the lower hole and tighten. (factory bolt: 76 in-lb; 3/8" bolt 30) {13mm,9/16"}

□□ Fasten the factory brake line bracket to the new bracket using the supplied 1/4" x 3/4" bolt, washer, and nyloc nut. (8) {1/2"}

□□ **CAUTION: DO NOT DAMAGE BRAKE HOSE.** Use a pair of vise grips and adjustable pliers to pry open the factory brake line bracket, that attached the hose to the top of the control

**Illustration 7**

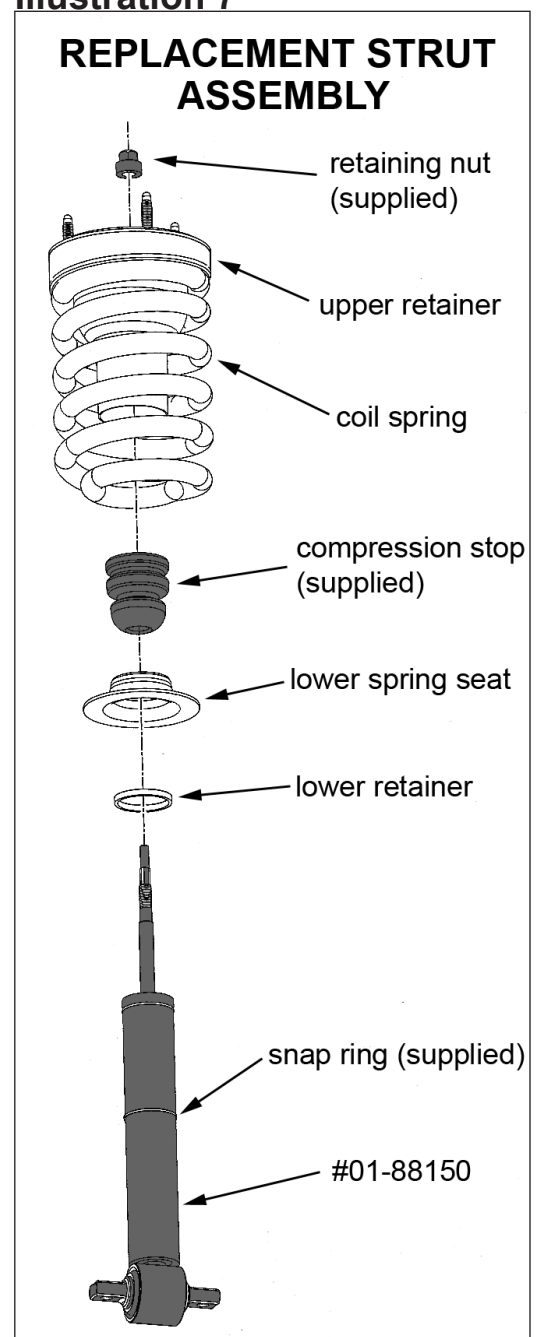

arm, free from the brake hose. Clamp the vise grips so they are gripping the edge and the back side of the radius, as shown. Then using the adjustable pliers, pry the bracket free. {vise grips, adjustable pliers}

**Illustration 8**

Attach the caliper bracket assembly to the knuckle. Apply the supplied thread-locking compound to the factory caliper bracket bolts and tighten (129). Be sure that the brake hose routing is exactly as shown in the Illustration. **NOTE: If the vehicle is equipped with stamped knuckles you must attach the caliper bracket using the supplied 14mm flange head bolt.**

[Illustration 9] Route the ABS wiring exactly as shown in the Illustration. Secure the wire to the tab on the knuckle as well as the upper control arm using the supplied zip ties. Reconnect the wiring at the frame.

## 21) TIE ROD ENDS...

**NOTE:** Perform the following steps one side at a time.

The jam nut for the tie rod end should have been loosened during disassembly. Remove the end and jam nut; set these parts aside.

[Illustration 10] Thread the supplied 16mm x 1.5 die nut on to the tie rod until it reaches the end of the factory threads.

Apply some cutting lubricant to the tie rod (male end) and die. Using a 16mm wrench on the flats present in the tie rod, hold the tie rod steady and use the die nut to cut an additional 1" of threads on the tie rod, or the approximate width of the die nut. Do not remove the die at this time.

Using a cut-off wheel or similar tool, cut 1" off of the end of the factory tie rod (male end). Use a thread file or die grinder to clean up any burrs caused by the cutting.

Unscrew the die nut from the tie rod, using it to "chase" the threads on the end of the tie rod where it was cut. The die should thread smoothly on and off the end of the rod.

Reinstall the factory jam nut, followed by the tie rod end. Final toe adjustments will take place once the suspension installation is complete. Snug the jam nut for now.

Attach the tie rod end to the knuckle using the factory nut and tighten (44).

Repeat these steps on the other side of the vehicle.

## 22) ANTI-SWAY BAR...

Attach the anti-sway bar drop brackets (#55-07-3500 driver side and #55-08-3500 passenger side) to the factory sway bar mounts on the frame using the supplied 10mm x 25mm bolts and flat washers. Note that the lower end of the brackets should be offset toward the rear of the vehicle, and that the C-shaped brackets should be pointed toward the center of the vehicle. Do not tighten at this time.

□□ Attach the anti-sway bar to the drop brackets using the factory bolts, supplied 10mm flat washers, and supplied 10mm Stover nuts. Tighten (50).

□□ Locate the new 3/8" x 12" bolts, the new sway bar tube (12-3492) and washer packs (145098). Place a supplied washer over the bolt followed by a factory bushing and insert from the bottom, through the lower control arm. Place another factory bushing and supplied washer on the bolt followed by the new sway bar link tube (12-3492), then a supplied washer and bushing. Push bolt through the sway bar body, then top off with the last factory bushing, factory washer, and supplied 3/8" nut. Tighten until the bushings swell slightly.

**23) TIRES / WHEELS...**

□ [Illustration 11] Tighten the lug nuts (140) in the sequence shown.

**WARNING:** When the tires / wheels are installed, always check for and remove any corrosion, dirt, or foreign material on the wheel mounting surface, or anything that contacts the

wheel mounting surface (hub, rotor, etc.). Installing wheels without the proper metal-to-metal contact at the wheel mounting surfaces can cause the lug nuts to loosen and the wheel to come off while the vehicle is in motion.

**WARNING:** Retighten lug nuts at 500 miles after any wheel change, or anytime the lug nuts are loosened. Failure to do so could cause wheels to come off while vehicle is in motion.

**WARNING:** Retighten lug nuts at 500 miles after any wheel change, or anytime the lug nuts are loosened. Failure to do so could cause wheels to come off while vehicle is in motion.

**24) CLEARANCE CHECK...**

□ With the vehicle still on jack stands, and the suspension "hanging" at full extension travel, cycle steering lock-to-lock and check all components for proper operation and clearances. Pay special attention to the clearance between the tires / wheels and brake hoses, wiring, etc.

**Illustration 9**

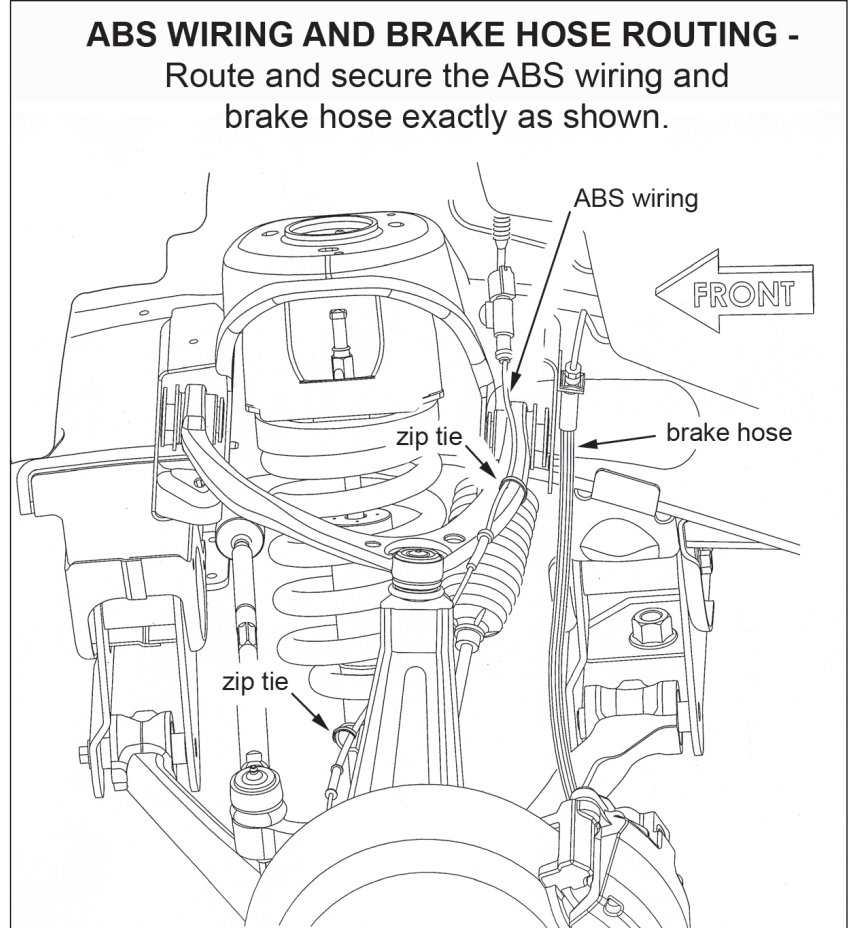

**Illustration 10**

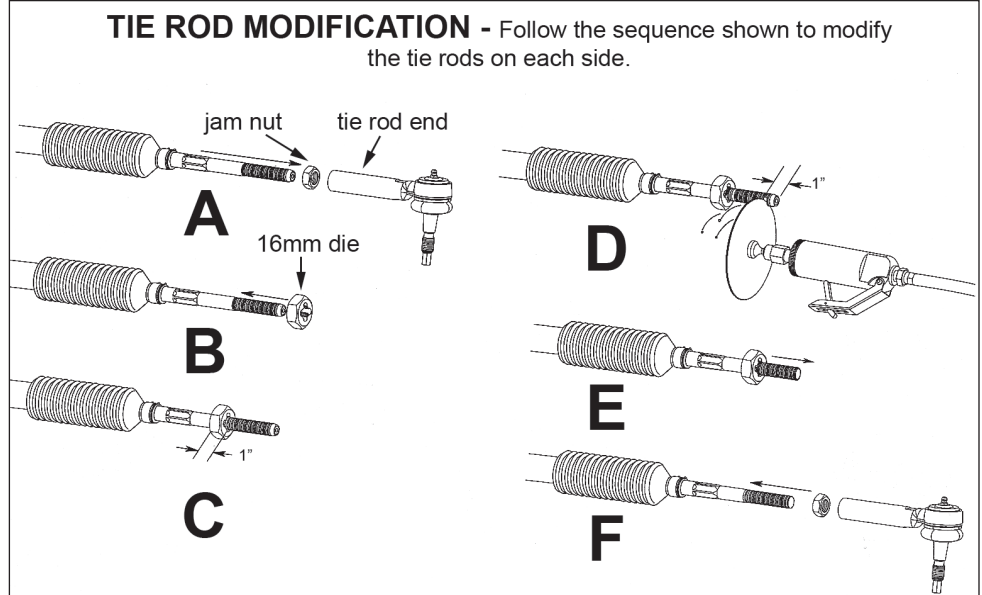

- Lower vehicle to the floor.

## 25) FINAL HARDWARE TIGHTENING...

- Tighten the lower control arm bolts (129).

## REAR PROCEDURES

### 26) PREPARE VEHICLE...

- Raise rear of vehicle with a floor jack positioned under the rear axle. Place jack stands under the frame rails, a few inches in front of the rear springs' front hangers. Ease the jack down until the frame is resting on the stands. Keep a slight load on the jack. Chock front tires to prevent accidental movement.

- Remove the tires. Remove the shock absorbers.

### 27) REAR BRAKE LINES...

- Unbolt the rear brake hose bracket from the top of the driver side frame rail. This bracket secures the connection between the metal brake lines and rubber hoses from the frame.

- [Illustration 12] Carefully reform the metal lines so that the mounting foot for the bracket lines up with the bottom of the frame rail, directly below its original attachment point. Use extreme caution to avoid pinching or otherwise damaging the lines. Using the bracket as a template, mark the location of the new mounting holes to be drilled in the bottom of the frame.

- Move the brake lines out of harm's way and drill at the marked locations using a  $17/64$ " bit.
- Line up the bracket with the drilled holes and install the supplied  $5/16$ " x 1" self-tapping bolts. Tighten (13).

- Unbolt the compression stops from their mounting cups. Discard the hardware but save the stops for re-use.

### REAR DISC BRAKE MODELS ONLY...

- Disconnect the driver side emergency brake cable from brake adjuster at the frame. Route the cable over the axle tube and then re-attach it to the caliper. Re-attach to the caliper and check for proper operation.

- On the driver side lower shock mount there is a clamp that secures the driver side emergency brake cable to the axle. Unbolt the clamp, move to the axle pad and attach using the  $5/16$ " x 1" bolt, washer, and flange nut. Reinstall the bolt securing the brake line and tighten to factory specifications.

**Illustration 12**

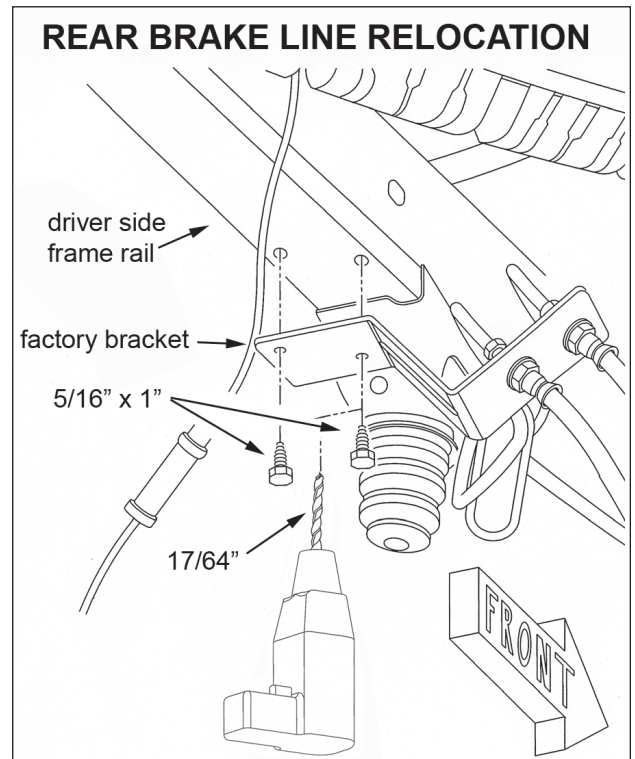

**28) SPRING PACK DISASSEMBLY...**

- Remove spring to axle U-bolts and move axle several inches away from springs.
- Place C-clamps approximately six inches on either side of the leaf springs center bolt. Pinch the tie bolt head (the portion that was located in the spring perch) with a pair of pliers, then remove the tie bolt nut. Remove the roll pin from the overload leaf and discard. Once the nut has been removed, loosen the C-clamps. **NOTE:** Be cautious when releasing the C-clamps; the springs are under load and will “spring” apart when released.

**29) SPRING PACK ASSEMBLY...**

- On each side, insert the add-a-leaf between the number one and number two leaf from the axle side, in the proper pyramid order. Align the 3/8” hole in the add-a-leaf with the center bolt hole in the spring pack.
- Recompress the pack with the C-clamp, not the center bolt, to avoid stripping the bolt or nut threads. Once the spring is compressed, insert the 3/8” x 5” center bolt through the leaf spring pack. Tighten the center bolt nut (45). Once tightened, trim excess bolt. Remove the C-clamps.

**30) LIFT BLOCKS AND SHOCK ABSORBERS...**

- Clean spring pads of all debris.
- Position the Superlift block on top of the factory block, then using the floor jack(s), mate the springs to the blocks, be sure that the center bolt heads seat properly. Install the new Superlift U-bolts and factory U-bolt plate. Evenly torque the U-bolts using an “X” tightening sequence (85).
- Install the rear shock absorbers. Position a supplied 3/4” SAE washer at the top and bottom of the shock on the inside of the bracket and tighten the upper and lower bolts (76).

**31) ABS WIRING AND FINAL CLEARANCE...**

- Disconnect rear ABS plug located on the top of frame above the compression stops. Also, remove the two retaining clips from frame (one on top of frame and one on the bottom).
- Raise rear of vehicle so that the suspension is at full extension and place on jack stands.

- Holding the bottom retaining clip, pull the ABS wire trough the rubber grommet until there is enough slack that the wires are no longer in a bind at full extension.

- Reconnect ABS plug making sure not to bend the pins. Insert only the bottom retaining clip into the frame. The top retaining clip will remain loose.

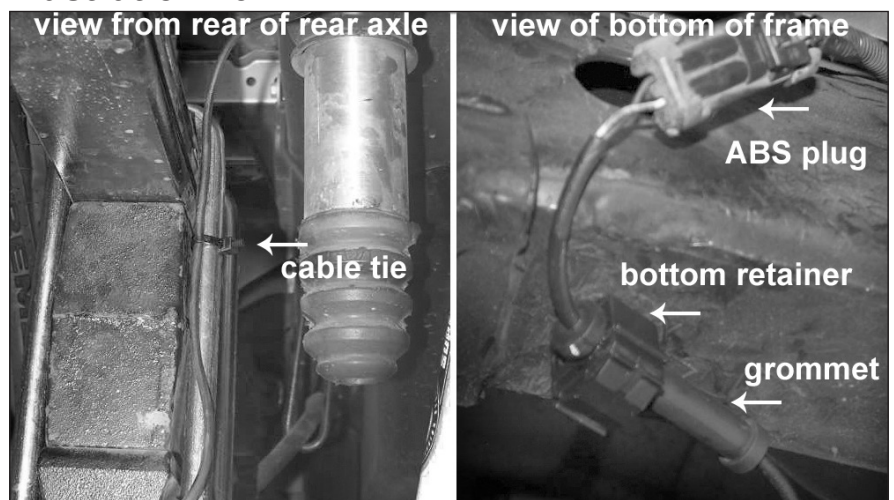
**Illustration 13**

- [Illustration 13] Pull the ABS wire up from the axle along the rear U-bolt and zip tie to U-bolt.

### 32) TIRES / WHEELS...

- [Illustration 14] Tighten the lug nuts (140) in the sequence shown.

**WARNING:** When the tires / wheels are installed, always check for and remove any corrosion, dirt, or foreign material on the wheel mounting surface, or anything that contacts the wheel mounting surface (hub, rotor, etc.). Installing wheels without the proper metal-to-metal contact at the wheel mounting surfaces can cause the lug nuts to loosen and the wheel to come off while the vehicle is in motion.

**WARNING:** Retighten lug nuts at 500 miles after any wheel change, or anytime the lug nuts are loosened. Failure to do so could cause wheels to come off while vehicle is in motion.

### 33) CLEARANCE CHECK...

- With the vehicle still on jack stands, and the suspension “hanging” at full extension travel, check all components for proper operation and clearances. Pay special attention to the clearance between the tires / wheels and brake hoses, wiring, etc.

- Lower vehicle to the floor.

### 34) BLEEDING THE BRAKE SYSTEM...

- Bleed the brake system following the procedure found in the factory service manual.

### 35) FOUR WHEEL DRIVE...

- Activate four wheel drive system and check front hubs for engagement.

### 36) HEADLIGHTS...

- Readjust headlights to proper setting.

### 37) SUPERLIFT WARNING DECAL...

- Install the “WARNING TO DRIVER” decal on the inside of the windshield, or on the dash, within driver’s view. Refer to the “NOTICE TO DEALER AND VEHICLE OWNER” section below.

### 38) SUPERLIFT BADGES...

- This kit is packaged with a small Superlift badge for a location of your choosing and one large badge for the front crossmember. Prior to installation, use the supplied alcohol pad to eliminate all soap and or other non-adhering residues that may impair adhesion, thoroughly clean the entire area of placement.

- Remove the adhesive back and place the large badge on the front crossmember, using the holes for alignment. The adhesive on our badges is pressure sensitive and must be applied using pressure on all areas of the graphic. Like any PSA (pressure sensitive adhesive), it can take up to 72 hours for the adhesive to fully cure. Once the badge is in place do not peel it up, this will diminish the adhesive properties and could result in damaging the badge itself. Also included are two rivets to be used for extra security.

### Illustration 14

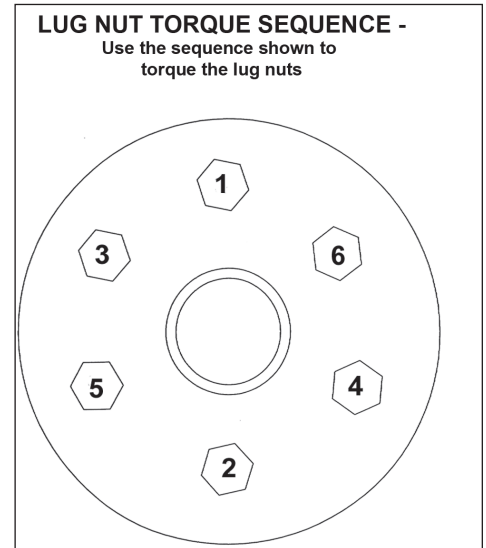



## TEMPLATE 1 - DRILL TEMPLATE FOR THE LOWER CONTROL ARMS.

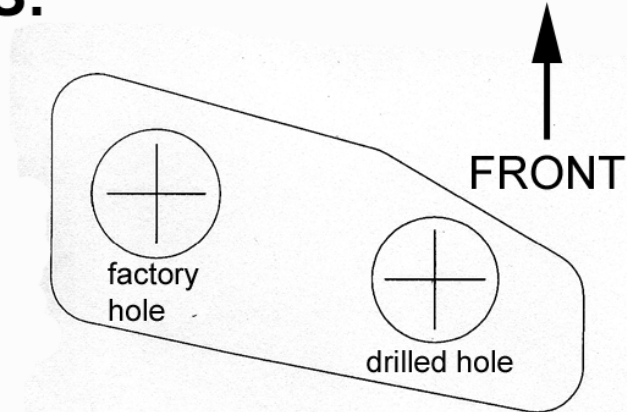

## TEMPLATE 2 - FOR ALUMINUM LOWER CONTROL ARMS

