



SUPERLIFT®

S U S P E N S I O N

Superlift 1986 - 1996 TOYOTA IFS 4" to 5" [Standard Lift System](#) INSTALLATION INSTRUCTIONS

INTRODUCTION

Installation requires a professional mechanic. Prior to beginning, inspect the vehicles steering, driveline, and brake systems, paying close attention to the track bar, suspension link arms and bushings, anti-sway bars and bushings, tie rod ends, pitman arm, ball joints and wheel bearings. Also check the steering sector-to-frame and all suspension-to-frame attaching points for stress cracks. The overall vehicle must be in excellent working condition; repair or replace all worn parts.

Read instructions several times before starting. Be sure you have all needed parts and know where they install. Read each step completely as you go.

NOTES:

- The rear lift is performed first. The rear components are sold separately and include separate instructions.
- Front end realignment is necessary.
- An arrow on diagrams indicates which direction is toward the front of the vehicle.
- A foot-pound torque reading is given in parenthesis () after each appropriate fastener. Apply a thread-locking compound where the "TL" symbol is found.
- Do not fabricate any components to gain additional suspension height.
- Prior to drilling or cutting, check behind the surface being worked on for any wires, lines, or hoses that could be damaged.
- After drilling, file smooth any burrs and sharp edges.
- Paint or undercoat all exposed metal surfaces.
- Prior to attaching components, be sure all mating surfaces are free of grit, grease, undercoatings, etc.
- A factory service manual should be on hand for reference.
- Use the check-off box "☐" found at each step to help you keep your place. Two "☐☐" denotes that one check-off box is for the driver side and one is for the passenger side. Unless otherwise notes, always start with the driver side.

PARTS LIST ... The part number is stamped into each part or printed on an adhesive label. Identify each part and place the appropriate mounting hardware with it.

PART NO	DESCRIPTION (Qty.- if more than one)	NEW ATTACHING HARDWARE (Qty.- if more than one)
55-07-7055	differential lowering bracket..... driver side	(2) 7/16" x 1-1/4" bolt (2) 7/16" Nyloc lock nut
55-08-7055	differential lowering bracket..... passenger side, front	(1) 7/16" x 1-1/4" (1) 7/16" Nyloc lock nut
55-29-7055	differential lowering bracket..... passenger side, rear	(2) 7/16" x 1-1/4" bolt (2) 7/16" Nyloc lock nut
55-11-7055	control arm crossmember, front..	(2) 5/8" x 4" bolt (2) 5/8" Stover lock nut (4) 1-7/8" x 1-13/16" tab
55-12-7055	control arm crossmember, rear...	(2) 5/8" x 4" bolt (2) 5/8" Stover lock nut (4) 1-7/8" x 1-13/16" tab
55-13-7055	front anti-sway bar lowering..... bracket, driver side	(2) 5/16" x 1" bolts (2) 5/16" Nyloc lock nut (6) 5/16" SAE flatwasher
55-14-7055	front anti-sway bar lowering..... bracket, passenger side	(2) 5/16" x 1" bolts (2) 5/16" Nyloc lock nut (6) 5/16" SAE flatwasher
55-19-7055	(2) compression travel	(2) 3/8" x 1" bolt
	bump-stop extension, front	
55-20-7055	(2) compression travel	(2) 3/8" x 1" bolt
	bump-stop extension, rear	
44-06-5040	(2) front brake hose	(2) 5/16" x 1" bolt
	relocation bracket	(2) 5/16" serrated flange nut (2) 3/8" USS flatwasher
55-01-7075	knuckle adapter, drivers side	(1) 5/8" x 2-1/2" bolt 77-0020 (1) 5/8" Nyloc nut (2) 3/32" x 1-1-2" cotter pin (1) tapered sleeve
55-02-7075	knuckle adapter,	(1) 5/8" x 2-1/2" bolt 77-0020
	passenger side	(1) 5/8" Nyloc nut (2) 3/32" x 1-1-2" cotter pin (1) tapered sleeve (1) tube thread locking compound

0034Superlift badgealcohol wipe pad

00461decal, "Warning To Driver"

FRONT DISASSEMBLY

1) PREPARE VEHICLE...

- ❑ Place the vehicle in neutral. Raise the front of vehicle and place jack stands underneath frame raise a few inches behind the sway bar mounting points. Ease vehicle down on to stands. Put transmission in gear or "park", set emergency brake and chock rear fires to prevent accidental movement. Remove the front tires.

2) ANTI-SWAY BAR and SKID PLATE...

- ❑❑ Unbolt the brackets that attach the front anti-sway bar body to the frame.
- ❑ Remove the stock skid plate located below the radiator. If the vehicle has a splash shield on either side of the radiator (not found on all models), remove these as well.

3) LOWER CONTROL ARMS (LCA) ...

- ❑❑ Remove front shock absorbers. On both sides, remove the 2 eccentric cam bolts that attach the LCA-to-frame; retain bolts for use later. Dislodge LCAs from their mounts, and let hang.

4) LCA CROSSMEMBERS (DIAGRAM 1)...

- ❑ Remove the differential-to-front crossmember bolt (save for reuse), then remove and discard the stock front crossmember. The #55-11-7055 front crossmember has axle mounting tabs, as shown. The rear crossmember, #55-12-7055, has a hole at each end of its main beam for the optional kicker braces to install. Mount the crossmember with these holes

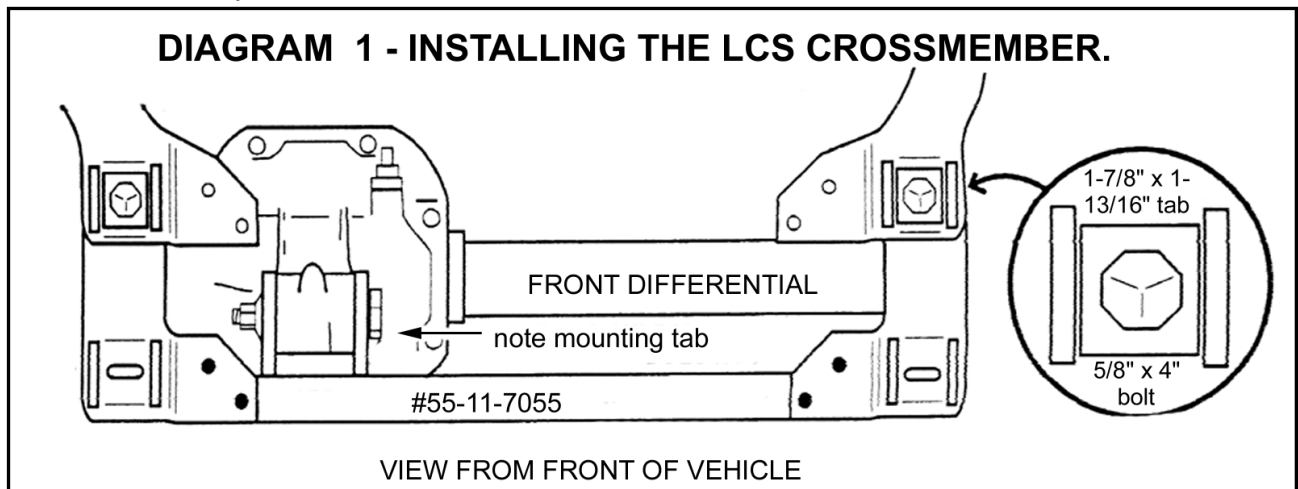

facing rear of vehicle.

- ❑ The 1-7/8 " x 1-13/16" tabs are used as locking washers for the 5/8" x 4" bolts that attach the Superlift crossmembers-to-frame pillars. It is not unusual for the frame pillars to be bent somewhat, causing misalignment. If you experience this, and mis-alignment is no more than 1/4", trim the tabs' width until they seat properly. If more than 1/4" mis-alignment exists, contact Superlift before proceeding.

NOTE: Both front and rear bolts should point rearward; do not tighten yet.

5) DIFFERENTIAL RELOCATION (DIAGRAM 2)...

- Place a floor jack beneath the differential and apply enough pressure to support its weight. The remaining attachment points are 5 bolts that mate with rubber insulated, frame mounted brackets. DIAGRAM 2 details the Superlift lowering brackets and reveals where these 5 bolts would be located. After removal, lower the differential to mate with its front crossmember mounting tabs. Loosely connect the two with the stock bolt, removed in Step 4.

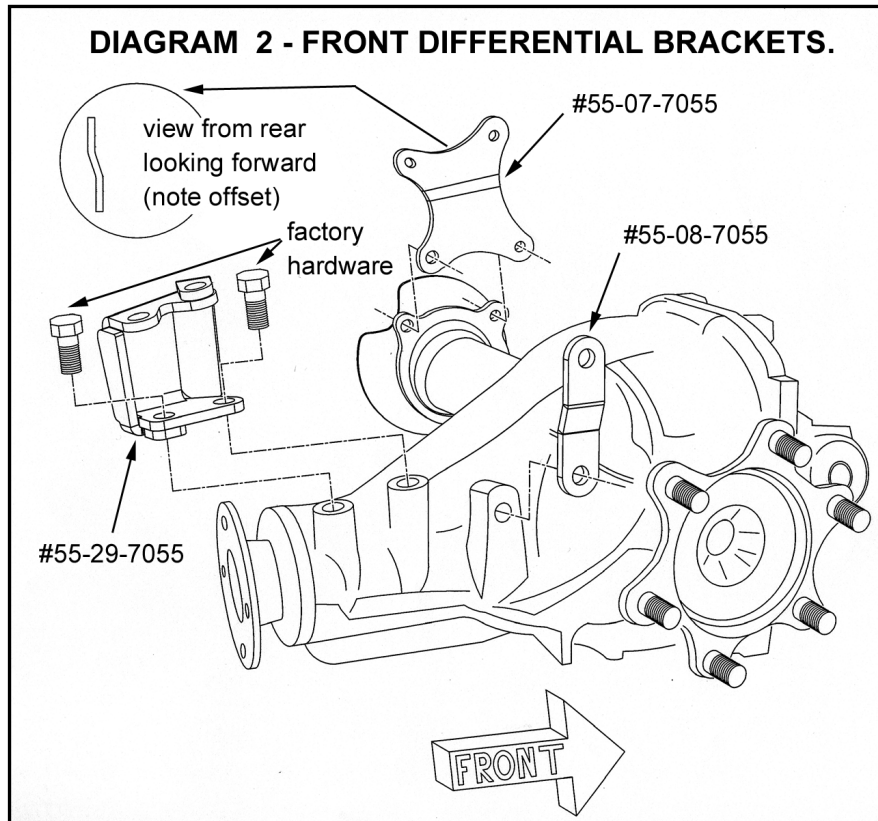

- Use stock hardware to loosely attach the 3 Superlift differential brackets to the differential; the furnished 7/16" hardware secures the brackets' upper ends. All differential bolts are tightened later.
- 6) REATTACHING LCAs...**
- Using a floor jack, mate the LCAs to the LCA crossmembers and attach using the stock cam bolts. The cam bolts should point towards the front on the front legs, and towards the rear on the rear legs. Adjust both cams to a neutral (centered) position (100).
 - Tighten the four 5/8 " LCA crossmember bolts (112), the differential-to-front crossmember bolt (48), and the remaining differential bolts (54 TL for stock bolts, 37TL for the supplied 7/16" bolts).
- 7) KNUCKLE ADAPTERS (DIAGRAM 3)...**
- Steps 7 through 10 are performed one side at a time.
- Remove the cotter pins and castellated nuts that attach the outer tie rod ends-to-knuckles, and detach ends using a puller tool.

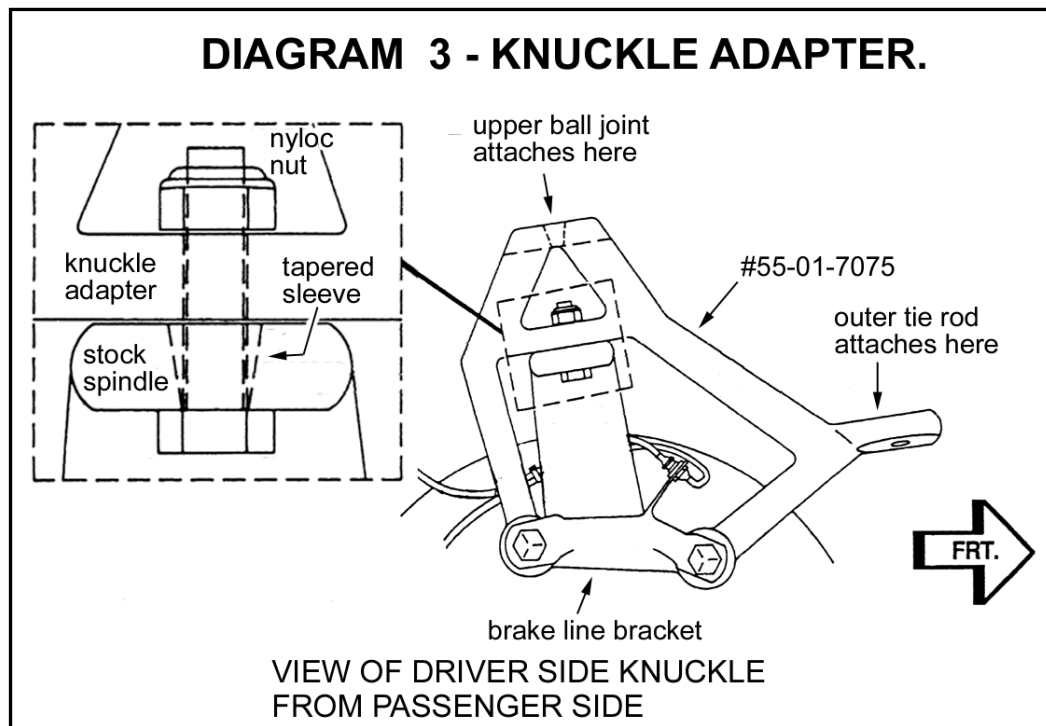

- Support the lower control arm with a floor jack and, using a puller tool, separate upper ball joint from spindle. Remove the two bolts that attach the steering knuckle arm to the spindle housing. These bolts also capture a brake line bracket.
- Thoroughly clean the upper ball joints tapered hole and insert the furnished tapered sleeve. Position and fit-check the new knuckle adapter. On some spindles, a slight casting ridge may be present that prevents the adapter from seating perfectly flush onto the spindle. If so, carefully dress the area using a flat file.
- With the knuckle adapter in place, reposition the stock brake line bracket and insert the two stock bolts (135 TL).
- Install the furnished 5/8" x 2-1/2" adapter-to-spindle bolt (112) pointing upward.

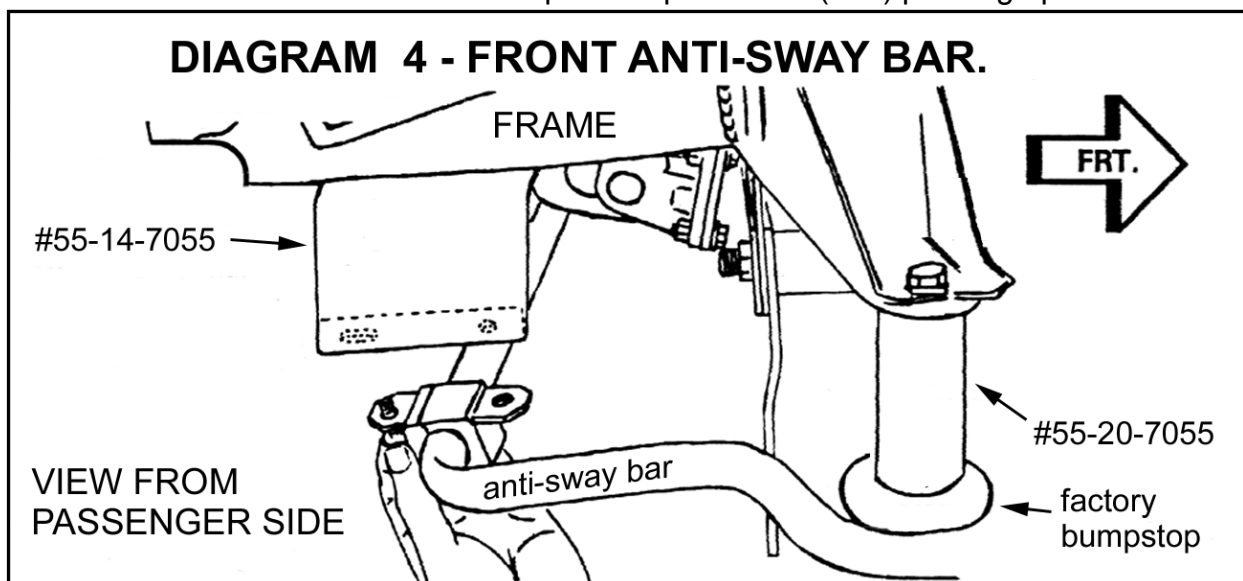

- Attach upper ball joint (105) and outer rod (67) to the adapter. New cotter pins are furnished for both.

8) COMPRESSION TRAVEL BUMP-STOP EXTENSIONS(DIAGRAM 4)...

- Extension #55-20-7055 is 3- 5/8" tall, and is for the lower control arm's rear leg bump-stop.
- Extension #55-19-7055 (3-1/8" tall) installs at the front leg. Use furnished 3/8"x 1" bolts (23 TL) on the top ends. The bump-stops' metric studs screw into the extension bottoms (TL).

9) SHOCK ABSORBER...

- Position the front shocks in their respective mounting locations. Check clearance, at full extension travel, between the shock body and the factory compression snubber.

NOTE: If a shock absorber with a body diameter larger than 2" is being used, you probably will have clearance problems between it and the front compression stop bracket. If so, drill a new bump-stop mounting hole approximately 1" inboard from the existing hole, and trim the mounting bracket accordingly.

- Tighten bottom bolt (101). Tighten upper end only until bushings swell slightly.

10) BRAKE HOSE RELOCATION BRACKETS (DIAGRAM 5)...

NOTE: If optional -longer Superlift replacement hoses are being installed, the relocation brackets are not used. Install the Superlift hoses per separate instructions.

NOTE: Do not loosen or disconnect the rubber brake hose from the metal line.

- Remove the clip that holds the top end of the rubber hose to its frame bracket; this is where the rubber hose mates to the metal line. Using a hacksaw or abrasive wheel, carefully slot the frame bracket and pull the hose / line from the bracket. Bolt the #44-06-5040 relocation bracket to the frame bracket, as shown, using the new 5/16" hardware (17).

- Carefully pull down and re-form the metal line as needed to mate the hose / line to the bottom of the relocation bracket. Attach using the factory clip.

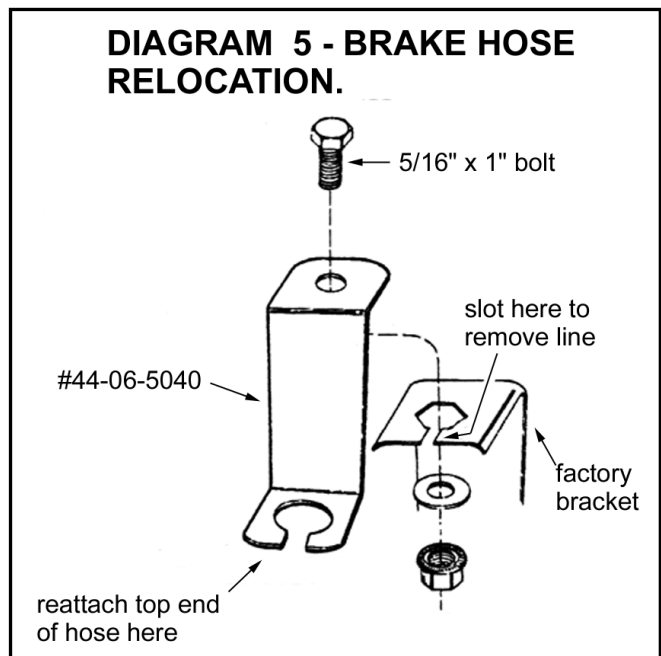

NOTE: The hard line will kink and collapse easily. Also, when routing, be sure the metal line does not make contact with the frame or any other components, or the line could eventually chafe through and fail.

- Perform Steps 7-10 on opposite side.

11) ANTI-SWAY BAR (DIAGRAM 4)...

- Attach the anti-sway bar drop brackets (#55-13-7055 driver side, #55-14-7055 passenger side) to the factory anti-sway bar attachment points on the frame using the factory bolts and the supplied 5/16" washers (9).
- Attach the anti-sway bar to the "13" and "14" brackets using the supplied 5/16" x 1" bolts, flat washers, and nyloc nuts (17).

12) SKID PLATE ...

- Reinstall the stock skid plate, or install optional Superlift plate using separate instructions.

13) REAR LIFT...

- The rear lift is purchased separately and has separate instructions. Install now.

14) TIRES / WHEELS...

- [DIAGRAM 6] Torque the lug nuts in the sequence shown (85 lb-ft).

WARNING: When the tires / wheels are installed, always check for and remove any corrosion, dirt, or foreign material on the wheel mounting surface, or anything that contacts the wheel mounting surface (hub, rotor, etc.). Installing wheels without the proper metal-to-metal contact at the wheel mounting surfaces can cause the lug nuts to loosen and the wheel to come off while the vehicle is in motion.

WARNING: Retighten lug nuts at 500 miles after any wheel change, or anytime the lug nuts are loosened. Failure to do so could cause wheels to come off while vehicle is in motion.

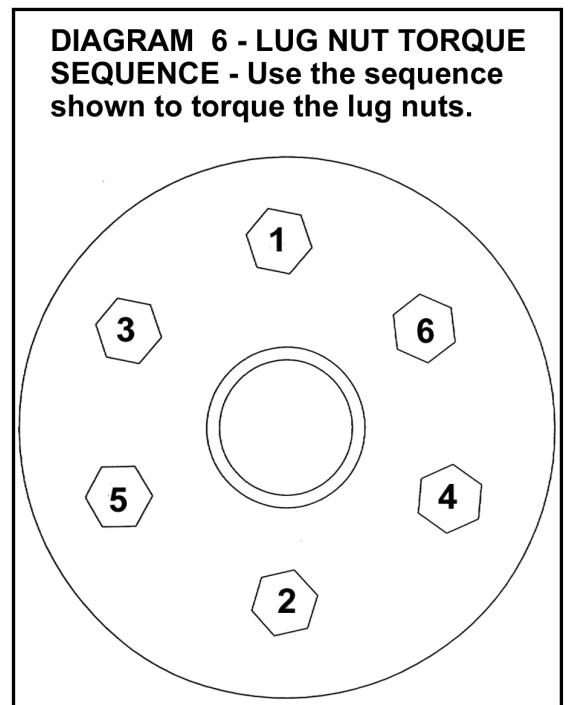

15) RIDE HEIGHT ADJUSTMENT (DIAGRAM 7)...

- Prior to lowering the front of the vehicle to floor, thoroughly clean and lubricate the torsion bars' adjusting nuts.
- After installing the tires, and lowering the vehicle to the floor, manually bounce the vehicle up and down to settle the suspension.
- Final ride height adjustments should be performed after the rear lift (purchased separately) is installed.

NOTE: To measure ride height, refer to DIAGRAM 7. Do not adjust vehicle to more than 5" of lift. Each bar may require slightly different adjustment to level the vehicle side-to-side.

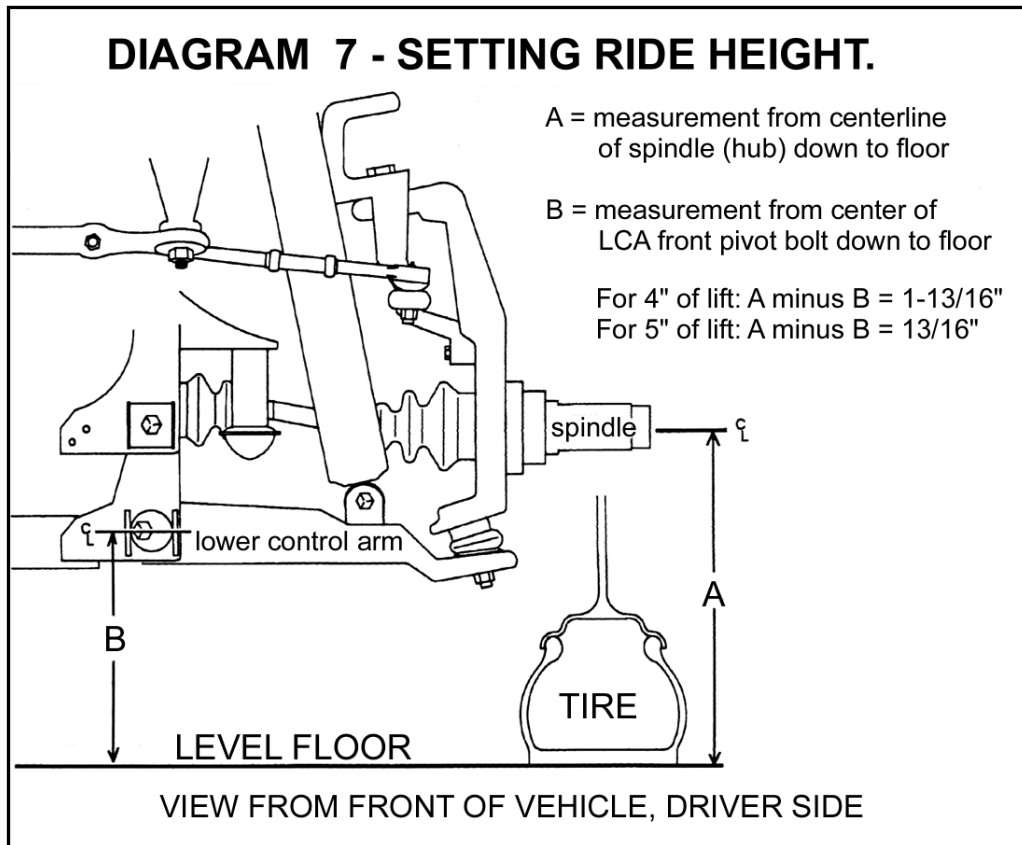

16) FINAL PROCEDURES...

- Raise the front of the vehicle with a pneumatic bumper jack. With the suspension unloaded and hanging, cycle steering lock-to-lock while manually spinning the tires, and inspect steering, suspension, and driveline systems for proper operation and clearances.
- Carefully inspect brake hoses for clearance, adequate length, and leakage.
- Lower vehicle to floor, and with the suspension supporting vehicle weight, repeat inspection. Adjust turning radius stop bolts if necessary
- Recheck all suspension, steering, and driveline system fasteners for proper tightness.
- Recheck brake system.

17) Activate four wheel drive system and check front hubs for engagement

18) HEADLIGHTS...

- Readjust headlights to proper setting.

19) SUPERLIFT NAME BADGE AND WARNING DECAL...

The system includes one 2" x 5" name badge (#0034). Additional and / or larger badges are available from Superlift or a Superlift dealer. We suggest putting the badges on the front fenders, tailgate, or rear window. The badge mounts by means of factory applied, double-backed tape. Follow these instructions to ensure that badge sticks properly:

- Clean designated area with warm, soapy water. Rinse and wipe dry with a soft, lint free towel.
- Thoroughly prep the area with the furnished alcohol wipe pad and wipe dry with a soft, lint free towel. Do not touch the surface again with your hands; they transfer body oils.
- Remove mounting tape backing, line up badge, and press in place. Do not touch mounting tape or allow tape to get dirty.
- Press firmly on the badge face and hold a few seconds to seat mounting tape. A superior adhesive bond forms over time. We recommend allowing 24 hours of cure time before washing and waxing. The emblem itself can be cleaned with any glass cleaner.
- Install the WARNING TO DRIVER decal on the inside of the windshield, or on the dash, within driver's view. Refer to the "NOTICE TO DEALER AND VEHICLE OWNER" section below.

20) FINAL CLEARANCE and TORQUE CHECK...

- With vehicle on floor, cycle steering lock-to-lock and inspect the tires / wheels, and the steering, suspension, and brake systems for proper operation, tightness, and adequate clearance.

IMPORTANT PRODUCT USE INFORMATION

As a general rule, the taller a vehicle is, the easier it will roll over. Offset, as much as possible, what is lost in roll over resistance by increasing tire track width. In other words, go "wide" as you go "tall". Many sportsmen remove their mud tires after winter / hunting season and install ones more appropriate for street driving; always use as wide a tire and wheel combination as possible to enhance vehicle stability.

We strongly recommend, because of roll over possibility, that the vehicle be equipped with a functional roll bar and cage system. Seat belts and shoulder harnesses should be worn at all times. Avoid situations where a side rollover may occur.

Generally, braking performances and capabilities are decreased when significantly larger / heavier tires and wheels are used. Take this into consideration while driving.

Do not add, alter, or fabricate any factory or aftermarket parts to increase vehicle height over the intended height of the Superlift product purchased. Mixing component brands is not recommended.

Most states have some type of law limiting vehicle height. The amount of lift allowed, and how the lift may be achieved, varies greatly. Several states offer exemptions for farm or commercially registered vehicles. It is the owner's responsibility to check state and local laws to ensure that their vehicle will be in compliance.

Superlift makes no claims regarding lifting devices and excludes any and all implied claims. Superlift will not be responsible for any altered product or any improper installation or use of our products.

We will be happy to answer any questions concerning the design, function, and correct use of our products.

IMPORTANT MAINTENANCE INFORMATION

It is the ultimate buyer's responsibility to have all bolts / nuts checked for tightness after the first 100 miles and then every 1000 miles. The steering, suspension and driveline systems, along with wheel alignment should be inspected by a qualified professional mechanic at least every 3000 miles.

NOTICE TO DEALER AND VEHICLE OWNER

Any vehicle equipped with a Superlift lifting device must have the enclosed "Warning to Driver" decal installed on the inside of the windshield or on the vehicle's dash, within driver's view. The "Warning to Driver" decal is to act as a constant safety reminder for whoever may be operating the vehicle. The WARRANTY IS VOID unless this decal is in place. **INSTALLING DEALER...** It is your responsibility to install warning decal and forward these installation instructions to the vehicle owner for review of warnings, product use and maintenance information. Replacement warning decals are available free upon request. These instructions are to be kept with the vehicle registration papers and owners manual for the service life of the vehicle.

SUPERLIFT LIMITED LIFETIME WARRANTY

Suspension products bearing the Superlift (LKI Ent.) name are warranted for as long as the original purchaser owns the vehicle that the LKI product was originally installed on. This warranty is non-transferable. Warranty covers only the product, no labor, time loss, or freight incurred. Any product that has been abused, altered, incorrectly installed, or used in competition is not covered. Product finish, spring bushings, Polyurethane products, and normal wear is not covered. The LKI product is subject to replacement or repair. No other warranties are expressed or implied. An authorized Superlift dealer must inspect the part in question and confirm that the "Warning to Driver" decal is properly displayed. A copy of the sales invoice is required for warranty consideration.