



**Superlift® 6-8" King Coilover System for 2011 - 2016
FORD F-250 / F-350 SUPER DUTY 4WD
INSTALLATION INSTRUCTIONS**

INTRODUCTION

Installation requires a professional mechanic. Prior to beginning, inspect the vehicles steering, driveline, and brake systems, paying close attention to the suspension link arms and bushings, anti-sway bars and bushings, tie rod ends, pitman arm, ball joints and wheel bearings. Also check the steering sector-to-frame and all suspension-to-frame attaching points for stress cracks. The overall vehicle must be in excellent working condition; repair or replace all worn parts.

Read instructions several times before starting. Be sure you have all needed parts and know where they install. Read each step completely as you go.

NOTES:

- If vehicle is factory equipped with a 2-piece rear driveshaft, Superlift's Carrier Bearing Drop Kit (#9669), purchased separately, is required.
- If vehicle is factory equipped with rear sway bar, Superlift's Sway bar Link Kit (#9069), purchased separately, is required.
- This system includes a bracket that allows the factory steering stabilizer cylinder to be retained. Due to the loads and harmonics generated by heavier tires / wheels, we recommend that Superlift's optional dual stabilizer system also be used.
- Special Tools Required:
 - The pitman arm-to-steering sector nut requires a 46mm or 1-13/16" socket.
 - A torque wrench capable of 406 ft. lbs.
- Do not install additional components or modify this system to gain additional suspension height.
- Front end realignment is necessary.
- Speedometer recalibration is recommended if a taller tire is used.
- An arrow on diagrams indicates which direction is toward the front of the vehicle.
- A foot-pound torque reading is given in parenthesis () after each appropriate fastener.
- Prior to drilling or cutting, check behind the surface being worked on for any wires, lines, or hoses that could be damaged.
- After drilling, file smooth any burrs and sharp edges.
- Paint or undercoat all exposed metal surfaces.
- Prior to attaching components, be sure all mating surfaces are free of grit, grease, undercoating, etc.

- A factory service manual should be on hand for reference.
- Use the check-off box “☐” found at each step to help you keep your place. Two “☐☐” denotes that one check-off box is for the driver side and one is for the passenger side. Unless otherwise noted, always start with the driver side.

PARTS LIST ... The part number is stamped into each part or printed on an adhesive label. Identify each part and place the appropriate mounting hardware with it.

PART NO.	DESCRIPTION (Qty.- if more than one)	ATTACHING HDW. (Qty.- if more than one)	HDW. BAG #
01-1116	pitman arm	cotter pin 30mm x 1.5 nut	77-9066-1
55-17-9026	compression dampener bracket for driver side, front	(2) 3/8" x 1-1/2" bolt 3/8" x 1" bolt (3) 3/8" SAE washer (3) 3/8" nyloc nut	77-9066-1
55-18-9026	compression dampener bracket for pass. side, front	(2) 3/8" x 1-1/2" bolt 3/8" x 1" bolt (3) 3/8" SAE washer (3) 3/8" nyloc nut	77-9066-1
66-09-9000.....	radius arm, driver side	(1) 18mm x 130mm bolt..... (2) 18mm washer (2) 18mm nyloc nut (1) Cam Bolts (1) Zip Tie	77-9500
66-10-9000.....	radius arm, passenger side	(1) 18mm x 130mm bolt..... (2) 18mm washer (2) 18mm nyloc nut (1) Cam Bolt (1) Zip Tie	77-9500
55-05-9024.....	(2) track bar key		77-9066-1
55-03-9066.....	track bar bracket, front		
55-01-9074.....	track bar bracket spacer		
55-03-9074.....	(2) front sway bar drop brackets..	(4) 7/16" x 1-1/2" bolt..... (8) 7/16" SAE washer (4) 7/16" nyloc nut	77-9074
55-04-9066.....	steering stabilizer bracket		

PART NO.	DESCRIPTION (Qty.- if more than one)	ATTACHING HDW. (Qty.- if more than one)	HDW. BAG #
55-09-9074 rear brake line bracket	(1) 7/16" x 1" bolt (2) 7/16" SAE washer (1) 7/16" nyloc nut	
55-05-9074 front brake line bracket, dr side		
55-06-9074 front brake line bracket, pa side		
SL5146-01(6")King Front Coilovers		
OR			
SL5146-02 (8")King Front Coilovers		
SL5171King Rear Shocks		
00461 decal, "Warning To Driver"		
00421 decal, Superlift® die-cut		
55-05-9066 (2) anti-sway bar link, rear.....	(4) hourglass bushing 77-9066-2 (4) 5/8" OD x 1.48" sleeve (4) 12mm x 70mm bolt (4) 1/2" USS washer	
(NOTE: SOLD SEPERATLEY)			

FRONT INSTALLATION PROCEDURE

NOTE: Save all factory components and hardware for reuse, unless noted.

- 1) **TRACK BAR...** Prior to raising the vehicle, disconnect the track bar from its frame attachment point, and let the bar hang.
- 2) **ANTI-SWAY BAR...** Disconnect the sway bar brackets from the frame.
- 3) **JACK STANDS...** Place vehicle in neutral. Raise front of vehicle with a jack and secure a jack stand beneath each frame rail, behind the radius arm mounts. Ease the frame down onto the stands, place transmission in low gear or "park", and chock rear tires. Remove front tires.
- 4) **SHOCK ABSORBERS...** Position a jack so that it supports, but does not raise, the front axle. Remove shocks.
- 5) **STEERING STABILIZER [SEE PHOTO]...**
 - Remove the steering stabilizer cylinder then unbolt the factory steering stabilizer bracket from the crossmember.

Position the steering stabilizer bracket to the track bar crossmember and fasten with the supplied 1/2" hardware. Attach the stabilizer to the steering stabilizer bracket (#55-04-9066) and tighten until bushings swell slightly.

6) **DRAG LINK...** Remove the cotter pin, castellated nut cover and nut attaching the drag link-to-pitman arm. Using the appropriate puller tool, separate the drag link from the pitman arm.

7) **BRAKE HOSE BRACKETS, VACUUM LINE...** Perform on each side:

A bracket attaches the brake line / hose assembly to the outboard face of the frame rail, just forward of the coil spring tower. Unbolt this bracket from the frame.

The rubber brake hose's lower end, and the 4WD activation vacuum line, are attached to the front axle via a bracket located in front of the coil spring's lower seat. Unplug the vacuum line where it passes through this bracket then unbolt the bracket from the axle.

8) **REMOVE COILS...** Carefully lower the front axle enough to facilitate coil springs' removal. Save the rubber isolators, located on top of the coils, for re-use.

9) **TRACK BAR BRACKET ...** Unbolt the factory track bar bracket from the frame.

10) **PITMAN ARM...**

NOTE: The pitman arm-to-steering sector nut requires a 46mm or 1-13/16" socket, not a box-end wrench. A torque wrench capable of 350 ft. lbs. is also required.

Note the pitman arm-to-sector shaft indexing. Remove arm-to-sector nut and, using the appropriate puller tool, remove the arm from the sector shaft.

IMPORTANT: The arm-to-sector nut is for "one time use" only. Discard the factory nut.

IMPORTANT: Thoroughly clean both the steering sector shaft splines and the new pitman arm splines; use paint thinner or brake cleaner.

Position #01-1116 pitman arm onto the sector shaft, in the same orientation as the factory arm, then install the supplied nut (350).

11) **TRACK BAR BRACKET...**

NOTE: Where this bracket attaches to the crossmember, there is often an excessive amount of undercoating build-up, especially on the back

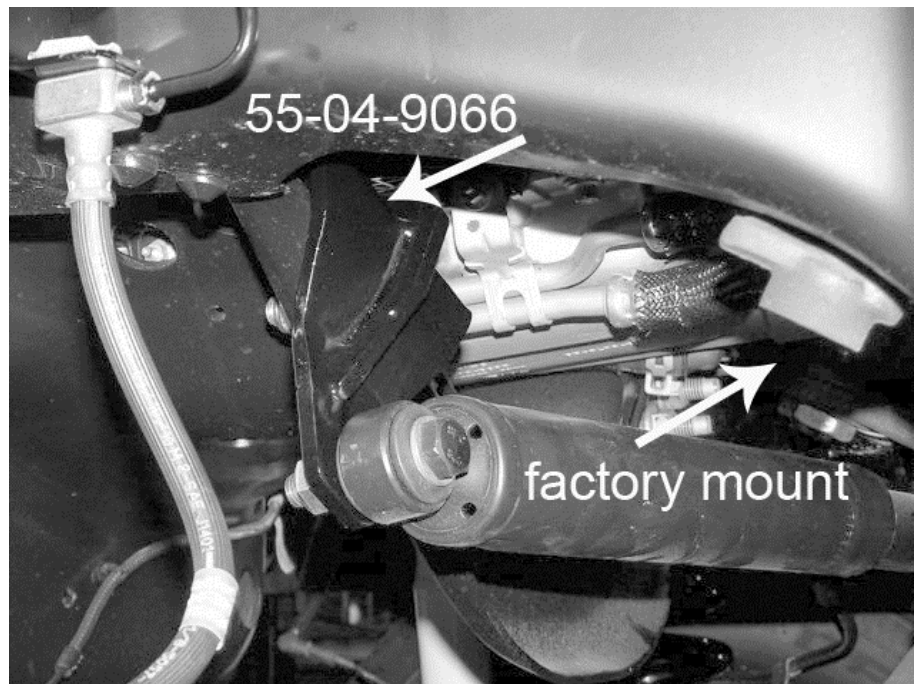

(rearward facing) portion of the crossmember. Scrape-off excessive undercoating to prevent the

track bar bracket from loosening over time.

[SEE DIAGRAM] Position the Superlift® track bar spacer (#55-01-9074) between the track bar bracket (#55-03-9066) on the frame on the rear hole in the factory location, and secure using the five factory bolts (136).

12) RADIUS ARMS...

NOTE: Perform the following steps one side at a time. Start on the driver side.

Unclip the ABS wire from the radius arm and secure it out of the way.

Verify once again that the axle is supported by the jack, then unbolt the radius arm from the frame and front axle. Save frame side hardware for re-use.

Attach the radius arm to the frame using the factory hardware. Attach the axle end using the 18 x 130MM bolt in the upper mount and the cam bolt in the lower. All hardware should be installed from the outside. Snug, but do not fully tighten at this time.

Repeat this procedure on the passenger side. All radius arm hardware will be tightened once the vehicle is on the ground.

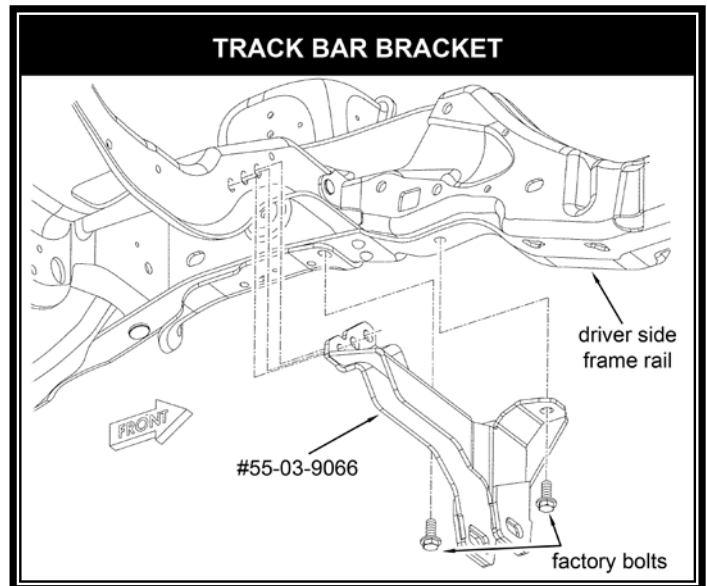

13) COMPRESSION TRAVEL DAMPENER BRACKETS... [SEE DIAGRAM] Perform step 13 one side at a time. Start on the driver side.

Pry the front compression travel dampeners out of its mounting cup then unbolt the cup from the frame.

Note that bracket #55-17-9026 is for driver side; #55-18-9026 is for passenger side. Position bracket #55-17-9026 onto frame, in the factory cup's location. There are two recesses in the bracket that align with two existing frame rivets. Also note that the bracket's inside edge is contoured to match a similar edge on the frame. Align the two contoured edges, then using the bracket as a template, mark the location for two mounting holes to be drilled.

Drill the two marked locations using a 3/8" drill bit. Also drill-out the mounting hole in the factory compression stop cup to 3/8".

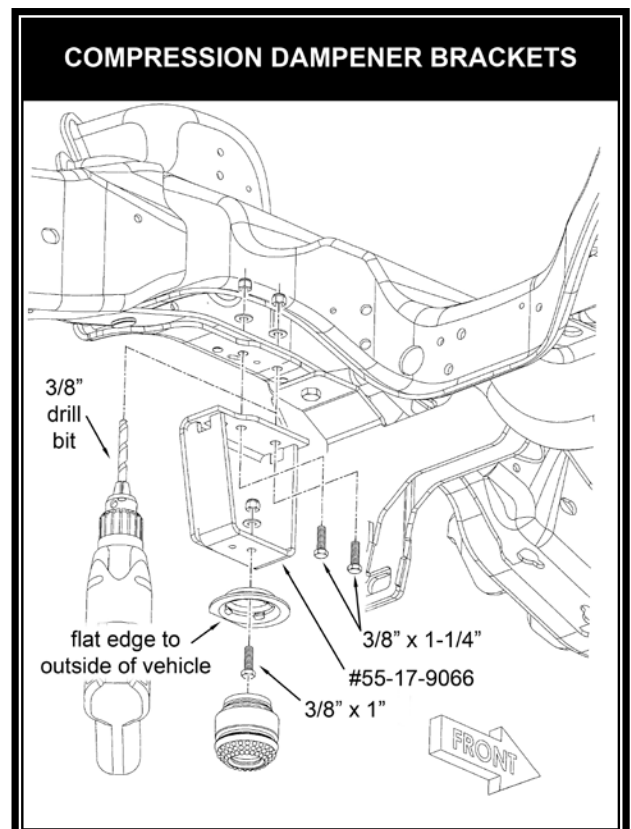

Attach the Superlift® bracket-to-frame using the supplied 3/8" x 1-1/2" bolts, pointing up, as shown. Place the washers on the frame side, install nyloc nuts and tighten (23).

Position the factory cup onto the Superlift® bracket. Insert the cup's alignment tab into the secondary hole in the Superlift® bracket. The cup should mate flush with the bracket, and its flat edge facing outboard, as shown.

Insert the supplied 3/8" x 1" bolt through the cup and bracket. Install washer and nyloc nut (23).

Press the factory compression dampener back into the mounting cup.

Perform step 13 on opposite side.

14) COILOVER SHOCKS...

Make sure the lower coil mount is free from any dirt or debris. Mount the lower coilover bracket on the axle as shown using the supplied hardware. (90)



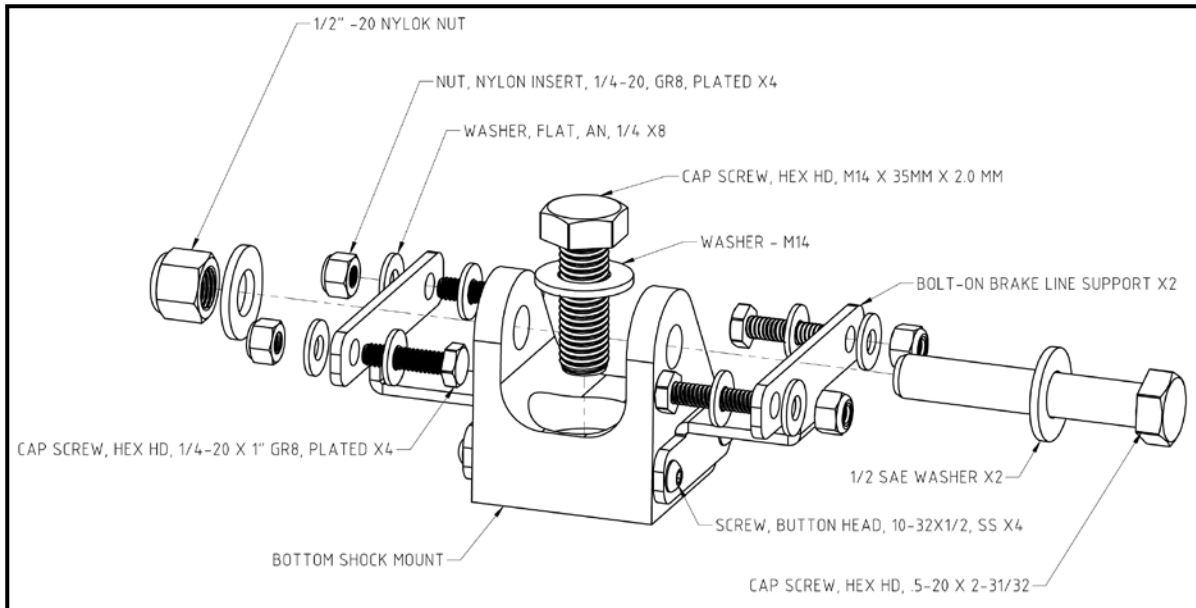

- Place the reservoir mount, located in the SL5146 box, over the upper factory coil locating boss. Carefully mark the three hole locations. Remove the bracket and drill 7/16" holes in the three marked locations. **WARNING:** Take extreme caution to not drill into anything located on top of the coil towers.
- Cut the coil spring locating boss flush with the upper coil mount. Grind any remaining edges of the coil spring locating boss so there is a smooth mounting surface.
- NOTE:** IF INSTALLING A 6" KIT....Before placing the coilover into the lower mount the coilover must be preloaded to the 6" lift height. To achieve this use the supplied adjustment tool to preload the coil 1.5", final adjustments to lift height can be done with the unit in the vehicle. The 8" units are a different part number and are ready to install with no preloading.
- Place the coilover into the lower mount and secure using the supplied hardware. (90)
- Insert the supplied 3/8" bolts into the holes in the coil tower. Note that the short (3/8" x 3/4") bolt goes in the outermost hole. Failure to have the bolts in the correct orientation can cause damage to the hose fitting on the coilover.
- Position the reservoir mount between the shock mount and the frame. Move the coilover into position and tighten the top mounting bolts. (35) Accessing these bolts through the engine compartment may be necessary.
- Center the reservoir in the mount and secure with the band clamps. Position the reservoir so hose is close to the inside of the wheelwell and tighten.
- Bolt the ABS line and the brake lines to the lower mount, making sure there is adequate clearance to any moving parts.



15) □ BRAKE HOSES... **NOTE:** Perform these steps one side at a time. Start on the passenger side.

□□ [SEE DIAGRAM] Factory brackets secure the brake hoses to the frame; these brackets were unbolted from the frame during disassembly. Completely remove the frame-mounting bracket from the brake hose by removing the horseshoe clip. Gently loosen the fitting between the hard line and the rubber hose just enough to rotate the hose so that it is pointing downward.

□□ Attach the new brake line brackets (#55-05-9074 driver side, 55-06-9074 passenger side) to the factory location using the factory hardware with the brake hose on the bottom side.

□□ Re-attach the lower brake hose brackets to the axle using the factory hardware and tighten (9).

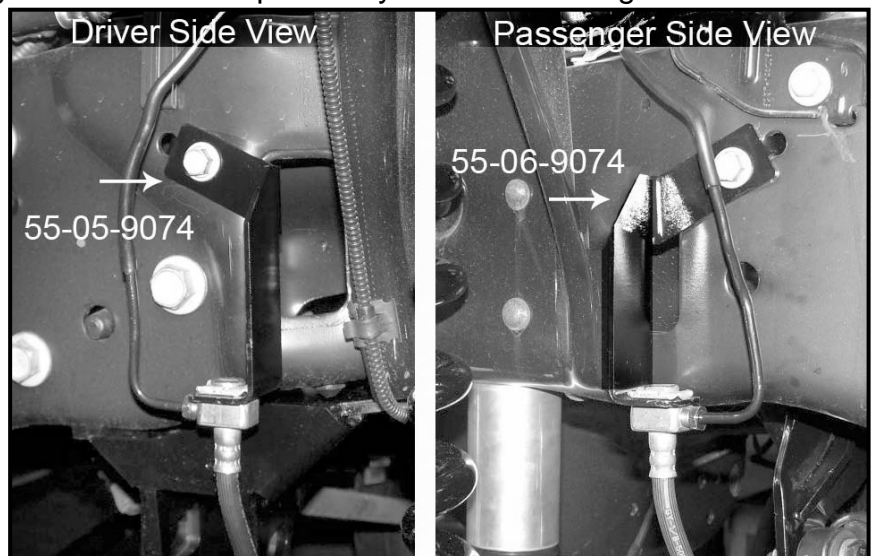

16) □ STEERING STABILIZER...
Install stabilizer cylinder; tighten until bushings swell slightly.

17) □ DRAG LINK... Reattach drag link-to-pitman arm (148) then install castellated nut cap and the supplied cotter pin. **NOTE:** Over-tightening may result in premature wear and / or failure.

18) □□ TIRES / WHEELS... [SEE DIAGRAM] Tighten the lug nuts (148) in the sequence shown.

WARNING: When the tires / wheels are installed, always check for and remove any corrosion, dirt, or foreign material on the wheel mounting surface, or anything that contacts the wheel mounting surface (hub, rotor, etc.). Installing wheels without the proper metal-to-metal contact at the wheel mounting surfaces can cause the lug nuts to loosen and the wheel to come off while the vehicle is in motion.

WARNING: Retighten lug nuts at 500 miles after any wheel change, or anytime the lug nuts are loosened. Failure to do so could cause wheels to come off while vehicle is in motion.

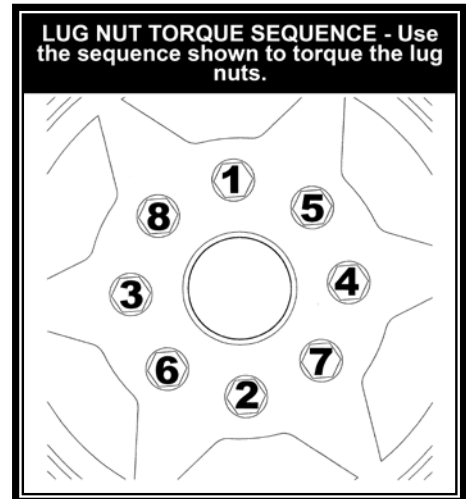

19) □□ JACK STANDS... Raise vehicle, remove jack stands and lower vehicle to the floor.

NOTE: The remaining front installation steps are performed with the suspension supporting vehicle weight.

20) □□ RADIUS ARMS... On both sides: Tighten factory bolts that attach radius arms-to-frame and axle (222). Reattach ABS wire-to-arm then reconnect ABS wire at the frame.

21) TRACK BAR...

□ Align the track bar's upper end with the slotted holes in the Superlift® track bar bracket.

□ Track bar keys (#55-05-9024) - The hole in each of the two keys is offset to one side. Insert the keys into the slots in the Superlift® bracket so the key holes are offset towards the driver side. Insert the factory track bar bolt and tighten (406).

IMPORTANT: Yes, the proper torque specification for the track bar eye bolt is 406 lb-ft; this is not a typographical error. If the appropriate torque wrench is not available, tighten the bolt as much as possible then take the vehicle to your Ford Dealer or a heavy equipment repair shop to perform the final torque operation. Proper bolt torque is critical.

22) □□ FRONT SHOCK-TO-AXLE BOLT -
On both sides, tighten bolt (136).

23) FRONT ANTI-SWAY BAR BRACKETS...[SEE PHOTO]

□□ Install the new drop brackets (#55-03-9074) on the frame using the factory hardware. The open part of the "C" should face the outside of the vehicle on the passenger side and the inside on the driver's



side. Attach the factory bracket to the new drop bracket using the supplied 7/16" x 1-1/2" hardware.

24) □□ INITIAL FRONT CLEARANCE CHECK... Again, raise the vehicle and place a jack stand under each frame rail just behind the radius arm attaching points. With the suspension "hanging" at full extension travel, cycle steering lock-to-lock and check all components for proper operation and clearances. Pay special attention to the clearance between the tires / wheels and brake hoses, wiring, etc.

25) □□ FINAL FRONT CLEARANCE and TORQUE CHECK... Raise vehicle, remove jack stands and lower vehicle to the floor. Cycle steering lock-to-lock and inspect the tires / wheels, and the steering, suspension, and brake systems for proper operation, tightness, and adequate clearance.

REAR INSTALLATION

26) □□ JACK STANDS... Raise rear of vehicle with a jack and secure a jack stand beneath each frame rail, just in front of the rear springs' front hangers. Ease the frame down onto the stands and chock front tires. Remove rear tires.

27) □□ SHOCK ABSORBERS... Position a jack so that it supports, but does not raise, the rear axle. Remove shocks.

28) □□ ANTI-SWAY BAR LINKS... Not all models are equipped with an anti-sway bar. Remove hardware securing the anti-sway bar links-to-bar body (at the axle).

29) □□ U-BOLTS... Remove spring-to-axle U-bolts. Use the jack to carefully lower the axle enough to facilitate add-a-leaf installation. Prior to removing factory blocks, note which side they are on, and their front / rear orientation.

30) □□ REAR BRAKE LINE BRACKET... [SEE PHOTO]

Unclip the rear axle vent hose from the top frame lip and re-clip to the bottom frame lip. Remove the rear axle vent hose from the barbed fitting. Remove the barbed fitting. Position the rear brake line bracket (#55-09-9074) under the factory bracket and attach it using the factory barbed fitting. Attach the factory bracket to the Superlift bracket using the supplied 7/16" hardware.

31) BLOCK KIT...

□□ Position Superlift® block onto axle; be sure that tall end of block faces towards rear of vehicle. Position factory block on top of Superlift® block in the same orientation as factory. Be sure all components seat and align properly.

□□ Evenly raise the axle until the factory blocks mate with the springs. Position U-bolt plates on

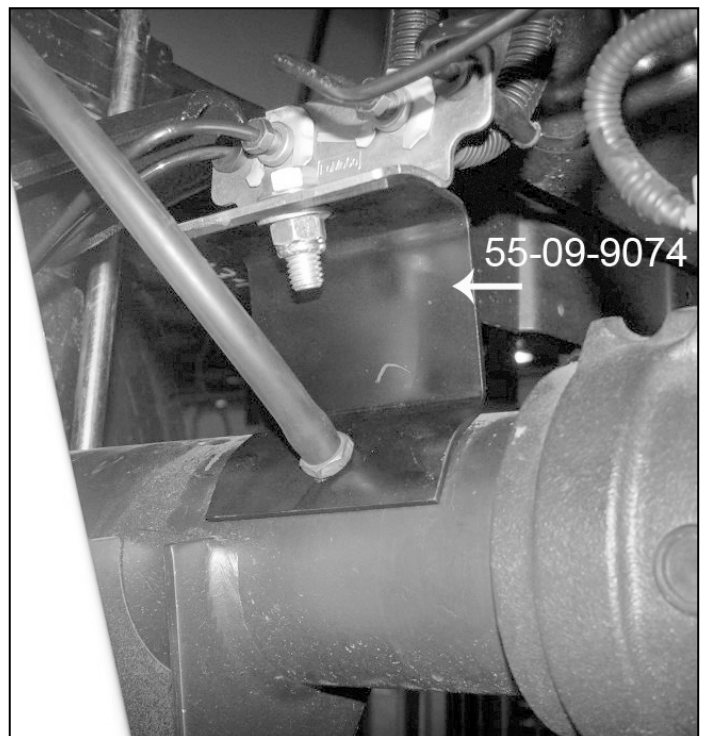

top of spring. Evenly tighten U-bolts using an "X" tightening pattern (145).

32) SHOCK ABSORBERS... Install the rear shock absorbers. Note the body of the cylinder is mounted to the frame and the shaft to the axle using the factory hardware. (76) Make sure there is adequate clearance between the reservoir hose and the frame rail and exhaust; adjust the position of the hose or reservoir if needed.

33) ANTI-SWAY BAR LINKS... (NOTE: SOLD SEPERATLEY)

Remove hardware securing the anti-sway bar links-to-frame.

Install supplied bushings and sleeves onto Superlift® links (#55-05-9066).

Install Superlift® links using the supplied 12mm x 70mm bolts, washers and factory nuts (80). Note that the links attach to the inboard sides of the bar body, and the outboard sides of the frame.

34) TIRES / WHEELS... Install tires / wheels. Refer to step 19 for warnings and proper torque information. Remove jack stands and lower vehicle to floor.

35) SHOCK ABSORBERS... With the suspension supporting vehicle weight, tighten rear shock mounts (85).

36) REAR CLEARANCE CHECK... Check all components for proper tightness, clearances and operation.

37) CARRIER BEARING DROP KIT... If vehicle is factory equipped with a 2-piece rear driveshaft, Superlift's drop kit, purchased separately, is required. Install per separate instructions.

FINAL PROCEDURES

38) 4WD SYSTEM CHECK... Activate 4WD system and check for engagement.

39) HEADLIGHTS... Readjust headlights to proper setting.

40) SUPERLIFT® WARNING DECAL... Install the WARNING TO DRIVER decal on the inside of the windshield, or on the dash, within driver's view.

41) ALIGNMENT... Realign vehicle to factory specifications.