



SUPERLIFT®

S U S P E N S I O N

Superlift Standard Series 6" lift system for 1999 - 2006 1/2-ton CHEVY SILVERADO / GMC SIERRA INSTALLATION INSTRUCTIONS

INTRODUCTION

Installation requires a professional mechanic. Prior to beginning, inspect the vehicles steering, driveline, and brake systems, paying close attention to the suspension link arms and bushings, anti-sway bars and bushings, tie rod ends, pitman arm, ball joints and wheel bearings. Also check the steering sector-to-frame and all suspension-to-frame attaching points for stress cracks. The overall vehicle must be in excellent working condition; repair or replace all worn parts.

Read instructions several times before starting. Be sure you have all needed parts and know where they install. Read each step completely as you go.

NOTES:

- **Prior to beginning the installation, check all parts and hardware in the box with the parts list below. If you find a packaging error, contact Superlift directly. Do not contact the dealer where the system was originally purchased. You will need the control number from each box when calling; this number is located at the bottom of the part number label and to the right of the bar code.**
- This system requires the use of wheels with a maximum 4-5/8" backspacing. Superlift recommends a 16x8 or 17x8 wheel with the equivalent of a 35x12.50 tire. This system will allow the use of a factory wheel and tire, but not a factory wheel with a larger-than-factory tire.
- Superlift recommends installing the TruSpeed speed signal calibrator on any vehicle with an electronic speedometer and larger-than-stock tires. The TruSpeed corrects the speedometer and other speed-signal related functions. The TruSpeed calibrator is available separately.
- Welding is required and must be performed by a certified professional. Refer to step 11.
- Bracketry is available separately that allows the vehicle to be returned to stock. If there is a possibility that the vehicle will be returned to stock in the future, all factory components and hardware should be saved for later use.
- A special tool is required to load / unload the torsion bars (step 2). Other special tools are recommended to detach / attach the ball joint / pitman / idler studs. Refer to the factory service manual.
- Front end realignment is necessary.
- This system utilizes the stock torsion bars, which normally yield the best ride quality. But, if the "final product" ride and handling seem too soft, heavier Gross Vehicle Weight Rating (GVWR) bars can be installed. Generally, heavier torsion bars are only needed to compensate for the extra weight of a winch or snowplow, or when the truck is subjected to extreme off-road use. Also, wider tires and wheels proportionally increase the leverage on

the bars, which results in lower ride height and a “spongier” ride. GM offers torsion bars with various rates that are heavier than stock. Your vehicle’s existing torsion bar rate can be identified by a 3-letter code stamped into the bars’ ends. The code is also on an adhesive tag wrapped around the bars.

- An arrow on diagrams indicates which direction is toward the front of the vehicle.
- A foot-pound torque reading is given in parenthesis () after each appropriate fastener.
- Do not fabricate any components to gain additional suspension height.
- Prior to drilling or cutting, check behind the surface being worked on for any wires, lines, or hoses that could be damaged.
- After drilling, file smooth any burrs and sharp edges.
- Prior to operating a welder, torch, or saw, protect any heat-sensitive components located in the immediate area by covering them with a water-saturated cloth. Most undercoating are flammable but can be extinguished using a water-filled spray bottle. Have a spray bottle and an ABC rated fire extinguisher on hand.
- Paint or undercoat all exposed metal surfaces.
- Prior to attaching components, be sure all mating surfaces are free of grit, grease, undercoating, etc.
- A factory service manual should be on hand for reference.
- Use the check-off box “☐” found at each step to help you keep your place. Two “☐☐” denotes that one check-off box is for the driver side and one is for the passenger side. Unless otherwise noted, always start with the driver side.

PARTS LIST ... The part number is stamped into each part or printed on an adhesive label. Identify each part and place the appropriate mounting hardware with it.

PART NO	DESCRIPTION (Qty.- if more than one)	NEW ATTACHING HARDWARE (Qty.- if more than one)
01-3330	knuckle, driver side.....	(1) 1/4” x 1/2” self-tapping bolt (3) zip tie (1) thread-locking compound
02-3330	knuckle, passenger side	(1) 1/4” x 1/2” self-tapping bolt (3) zip tie (1) thread-locking compound
55-04-3330	differential drop bracket, passenger side	(2) 9/16” x 2” bolt (2) 9/16” extra-thick flat washer (4) 9/16” USS washer (2) 9/16” nyloc nut
55-05-3370	front crossmember.....	(2) 5/8” x 4-1/2” bolt (4) 5/8” USS washer (2) 5/8” nyloc nut

55-06-3370	rear crossmember	(1) 9/16" x 4-1/2" bolt (2) 9/16" USS washer (1) 9/16" nyloc nut (2) 5/8" x 5-1/2" bolt (4) 5/8" USS washer (2) 5/8" nyloc nut
1-07-3370	frame reinforcement bracket	
55-11-3370	belly pan.....	(2) 3/8" x 1-1/4" bolt (4) 3/8" SAE washer (2) 3/8" nyloc nut (2) 5/16" x 1-1/4" bolt (4) 5/16" SAE flat washer (2) 5/16" nyloc nut
55-11-3330	differential bracket, upper, driver side	(1) 9/16" x 4" bolt (2) 9/16" USS washer (1) 9/16" nyloc nut (2) poly bushing half (1) 3/4" OD x 2-3/8" sleeve
55-12-3330	torsion bar drop bracket, driver side	(2) 7/16" x 1" bolt (2) 7/16" x 1-1/2" bolt (8) 7/16" SAE washer (4) 7/16" nyloc nut (4) extra thick washer (4) bushing half (2) 11/16" x 1-1/2" sleeve
55-12-3330	torsion bar drop bracket, passenger side	(2) 7/16" x 1" bolt (2) 7/16" x 1-1/2" bolt (8) 7/16" SAE washer (4) 7/16" nyloc nut (4) extra thick washer (4) bushing half (2) 11/16" x 1-1/2" sleeve
66-15-3330	(2) CV axle spacer	(12) 10mm x 70 mm bolt (12) 10mm flat washer
55-19-3280	(2) compression stop..... extension, rear	(4) 3/8" x 1" bolt (8) 3/8" USS washer (4) 3/8" nyloc nut
55-21-3370	(2) front anti-sway bar link.....	(2) 1/2" x 1-1/4" carriage bolt
.....	(2) 1/2" flange nut
.....	(2) 7/16" stover nut (2) 7/16" SAE washer (2) 7/16" nyloc nut (2) sleeve

		(4) poly bushing half
55-26-3280.....	(2) rear emergency brake cable drop bracket	(2) 3/8" x 1" bolt (2) 3/8" SAE washer (2) 3/8" nyloc nut
	stock rear brake line bracket	(2) 1/4" x 1" bolt (2) 1/4" SAE washer (2) 1/4" nyloc nut
	(2) shock absorber, front	(2) shock boot*, yellow (2) hardware pack and cable tie
*(NOTE: Shock boots, if desired, purchased separately)		
	(2) shock absorber, rear	(2) shock boot*, yellow (4) 1/2" USS washer (2) hardware pack and cable tie
*(NOTE: Shock boots, if desired, purchased separately)		
0034.....	Superlift badge	alcohol wipe pad
00461	decal, "Warning To Driver"	

FRONT DISASSEMBLY

- 1) **PREPARE VEHICLE...**
 - Place vehicle in neutral. Raise the front of vehicle with a jack and secure a jack stand beneath each frame rail, behind the lower control arms. Ease the frame down onto the stands, place transmission in low gear or "park", and chock the rear tires. Remove the front tires.
 - Disconnect the battery.
- 2) **UNLOADING THE TORSION BARS...**

WARNING: Be extremely careful when loading and unloading the torsion bars; there is a tremendous amount of energy stored in them. Keep your hands and body clear of the adjuster arm assembly and the puller tool in case anything slips or breaks.

 - Mark the torsion bars to indicate their indexing in relation to the lower control arms and adjusting arms.
 - A special torsion bar puller tool is required to unload the torsion bars. Use the tool to load the torsion bar, then remove the adjusting bolt and nut block. Unload the bar, slide the adjuster arms out of the crossmember, then slide the torsion bars forward (into the lower control arms).

NOTE: Because of the extreme loads generated by the torsion bars on these vehicles, a standard two-jaw puller tool tends to bend the "lips" of the crossmember (which it uses for attachment) and may pop out of place. We have had the best results using a C-clamp type puller tool. If one cannot be found locally, this tool (PN J-22517-C) is available from the Kent Moore Tool Group in Roseville, Michigan (800/345-2233 or 313/774-9500).

3) TORSION BAR CROSSMEMBER...

- Remove the two bolts that attach the crossmember to the frame and set the crossmember aside. Save all hardware for re-use.

4) BRAKE CALIPERS...

- Unbolt the brake hoses from the upper control arm.
- Remove the two bolts securing the caliper bracket to the knuckle. It is not necessary to remove the caliper from the bracket. Leave the brake hose attached to the caliper, and using mechanic's wire, hang the calipers out of the way. Take precautions to ensure the brake hose isn't stretched or pinched.
- Unplug the ABS wire from the connector located at the top of the frame rail and unclip the wire from the upper control arm.
- Remove the brake rotor and set it aside.

5) AXLESHAFTS...

- Remove any factory skid plates or shields that block access to front suspension components.
- Remove the six bolts that attach the axlehaft to the CV flange on the differential.

6) TIE ROD ENDS...

- Remove the nuts securing the tie rod ends to the knuckle. Using the appropriate puller tool (refer to the factory service manual), separate the tie rod end from the knuckle.

7) SWAY BAR...

- Loosen the threaded rod inside the sway bar end link and remove the bushings, rod, and tube. Set these parts aside.

8) CONTROL ARM / HUB ASSEMBLY...

- Remove and discard the front shocks. Save the lower shock hardware for re-use.
- Mark the axlehafts' respective positions (Driver and Passenger).
- Remove the dust cap in the center of the wheel bearing assembly in order to gain access to the axlehaft nut. Remove the axlehaft nut, then remove the axlehaft from the vehicle. Save all hardware for re-use.
- Support the control arm / hub assembly with a jack. Remove the upper ball joint nut securing the knuckle to the upper control arm. Using the appropriate puller tool, separate the upper ball joint from the knuckle. Save all hardware for re-use.
- Remove the lower ball joint nut and, using the appropriate puller tool, separate the ball joint from the knuckle. Set the knuckle (with the wheel bearing assembly still attached) aside.
- Remove the bolts that hold the lower control arm to the frame and set the lower control arm aside. Save all hardware for re-use.

9) COMPRESSION TRAVEL STOPS...

- Pry out the compression travel stops from their mounting cups and save for re-use.

10) DIFFERENTIAL...

- Disconnect the electrical plug and vacuum tube from the differential.
- Position a jack underneath the differential housing and place just enough pressure on the jack to support the differential's weight.
- Unbolt the driveshaft from the differential yoke and tie the driveshaft out of the way. Retain all the factory hardware.
- Remove and discard the factory rear crossmember.
- Remove the driver side lower differential bolt and the two differential bolts on the passenger side, followed by driver side upper differential bolt. Carefully lower the differential to the floor.

11) TRIMMING THE FRAME...

- [DIAGRAM 1] Cut the driver side lower differential mount following Diagram 1 using a torch or similar tool.

- Test-fit the supplied frame reinforcement bracket (#1-07-3370) as shown in Diagram 1. It may be necessary to trim the bracket in order to fit the installer's cut lines. Care should be taken to trim the piece as precisely as possible to ensure a good solid weld.

- Once the reinforcement bracket fits adequately, weld it to the frame as shown in Diagram 1.

DIAGRAM 1 - TRIMMING THE FRAME - Follow the steps below.

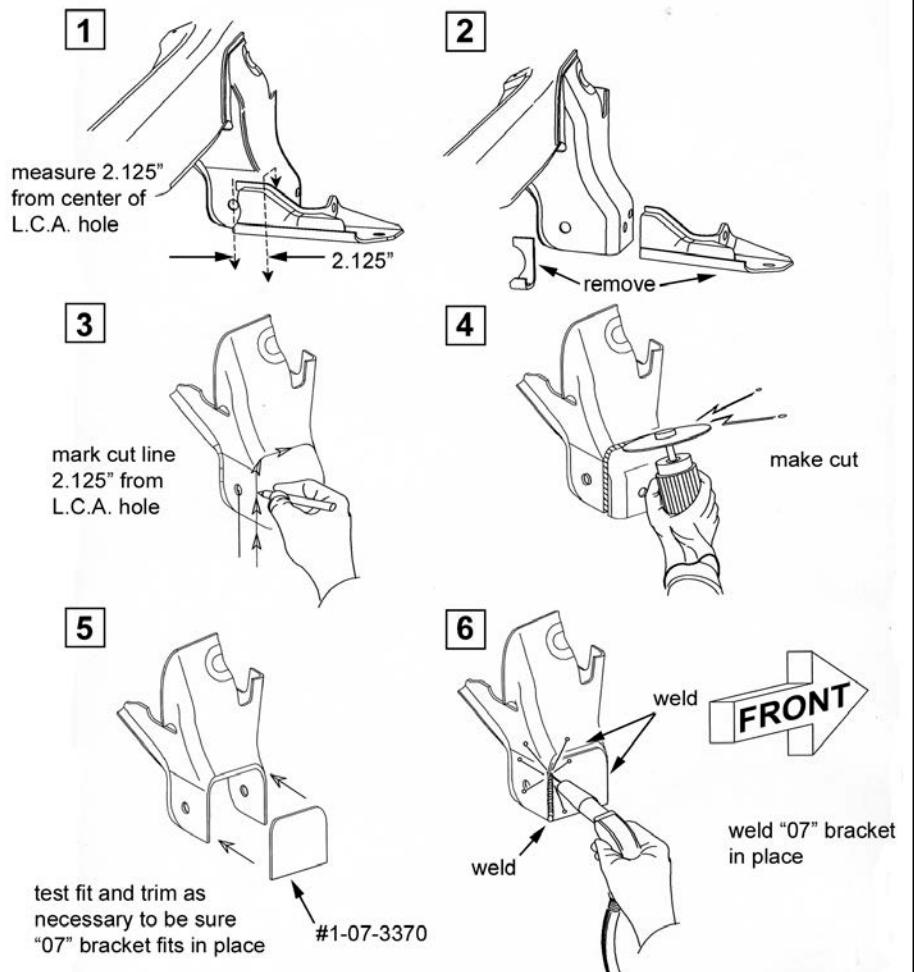

12) PASSENGER SIDE DIFFERENTIAL DROP BRACKET...

- [DIAGRAM 2] Look at the passenger side differential drop bracket (55-04-3330). Looking from the side of the bracket, you will notice it has a taper in it; the “tall” end of the taper should be positioned forward (toward the front bumper), while the “short” end of the taper should be positioned rearward (toward the rear bumper). Attach the “04” bracket to the factory passenger differential bracket as shown using the original hardware and two of the supplied 9/16” USS washers. Do not tighten at this time.

13) FRONT CROSSMEMBER...

- Attach the front crossmember (#55-05-3370) to the original lower control arm front leg mounting points on the frame using the supplied 5/8” x 4-1/2” bolts, washers, and nyloc nuts. The crossmember should be positioned so that the mounting tabs for the differential are pointing rearward (toward the rear bumper), and the bolts should be installed from the front. Do not tighten at this time.

14) DIFFERENTIAL...

- [DIAGRAM 2] Using a cut-off wheel or reciprocating saw, cut off the ear for the driver side upper differential mount as shown. Smooth the area that was cut for appearance and adequate clearance with other components.

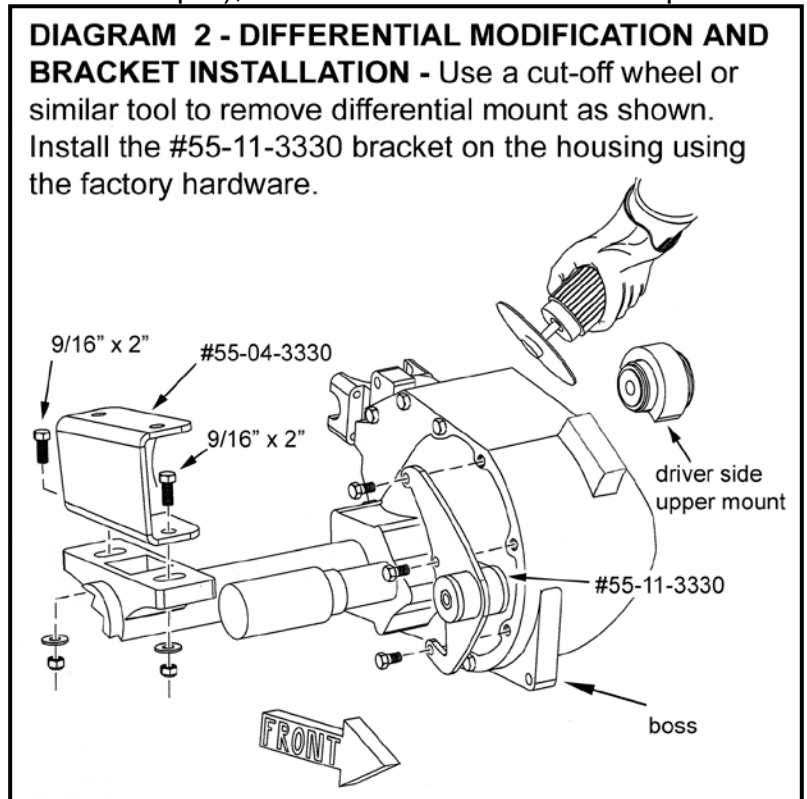

- WARNING:** Do not use a torch or similar tool that generates extreme heat to make the necessary cuts to the differential. Excessive heat will warp the differential housing and irrevocably damage it.
- Install the bushing halves and sleeve in the #55-11-3330 differential bracket using a silicon-based grease.
 - [DIAGRAM 2] Attach the #55-11-3330 to the differential housing as shown using the factory hardware and tighten (35).
 - With the help of an assistant, raise the differential into position and secure the driver side front mount (#55-11-3330) in the front crossmember tabs using the supplied 9/16” x 4” bolt, washer, and nyloc nut. The bolt should be installed from the outside. Do not tighten at this time.
 - Secure the passenger side of the differential to the “04” bracket using the two supplied 9/16” x 2” bolts, extra-thick flat washers, USS washers, and stover nuts. The bolts should be installed from the top, and the extra-thick washers should be positioned under the nuts. Do not tighten at this time.
 - Reconnect the differential vacuum tube and wiring.

15) REAR CROSSMEMBER...

- Position the rear crossmember (#55-06-3370) in the rear legs for the lower control arms and loosely secure using the supplied 5/8" x 5-1/2" bolts, USS washers, and nyloc nuts. The bolts should be installed from front-to-rear. Do not tighten at this time.
- Install the supplied 9/16" x 4-1/2" bolt, USS washers, and nyloc nut. The bolt should be installed from the outside. Do not tighten at this time.
- Re-install factory compression stops in the cups on the "06" crossmember.

16) BELLY PAN...

- [DIAGRAM 2] The boss on the front of the differential may need to be clearance for fitment of the belly pan.
- Position the belly pan (#55-11-3370) between the front and rear crossmembers and loosely secure to the rear crossmember using two of the the supplied 5/16" x 1-1/4" bolts, SAE washers, and 5/16" nyloc nuts. Secure the belly pan to the front crossmember using two 3/8" x 1-1/4" bolts, washers, and nyloc nuts.

17) FASTENER TIGHTENING SEQUENCE...

- Torque the following in sequence:
 - 5/16" belly pan hardware (19).
 - 3/8" belly pan hardware (23).
 - 5/8" crossmember hardware (154).
 - 9/16" differential hardware (114).
 - Factory hardware on passenger side differential bracket (75).

18) DRIVESHAFT...

- Reattach the front driveshaft using the factory hardware and tighten (19).

19) KNUCKLE ASSEMBLY AND INSTALLATION...

NOTE: Perform the following steps on one knuckle at a time.

- Install the lower control arm in the crossmembers using the factory hardware. Install the hardware for both legs front-to-rear. Snug, but do not tighten at this time.
- Remove the three bolts securing the wheel bearing assembly to the factory knuckle. Carefully note the orientation of the dust shield and wheel bearing assembly prior to removal.
- Install the bearing assembly and dust shield on the Superlift knuckle (#01-3330 driver side and #02-3330 passenger side) using the factory hardware. Be sure the orientation of the dust shield and bearing assembly matches original. Use the supplied thread-locking compound on the three factory fasteners
- Install the knuckle assembly (#01-3330 driver side and #02-3330 passenger side) on the upper and lower ball joints and secure using the factory nuts. Tighten the upper nut (37) and lower nut (94).

- Tighten the three factory bearing assembly bolts (133).

20) AXLESHAFTS...

- Turn each knuckle so that the front of the knuckle is pointing outward. Position and install the axleshafts according the marks made during removal (Driver and Passenger). This is done by passing the differential end of the axleshaft in front of the differential housing and then sliding the shaft through the hub assembly. Secure the shaft with the factory nut and tighten (148-165). Reattach the dust cap.
- Position an axleshaft spacer (#66-15-3330) between the flange on the axleshaft and the flange on the differential and secure using the supplied 10mm x 70mm bolts and flat washers. Tighten (58).

21) BRAKE CALIPERS AND ABS WIRING...

- [DIAGRAM 4] Install the brake rotor and attach the caliper bracket assembly to the knuckle using the factory hardware with the supplied Loc-Tite. Be sure to follow the brake hose routing as shown. Tighten (129).
- Modify the brake hose clip as shown in Diagram 4 and attach it to the upper control arm with the factory hardware. Attach the remaining brake hose bracket to the knuckle using the supplied 1/4" x 1/2" self-tapping bolt.
- Follow the routing for the ABS wiring and attach it to the brake hose using the supplied zip ties as shown in Diagram 4. Reattach the wiring to the connector on the frame.

22) TIE ROD ENDS...

- Attach the tie rods ends to the knuckle and secure using the factory hardware (50).

NOTE: The factory service manual recommends replacing the tie rod end nuts.

23) SHOCK ABSORBERS...

- Install the shock boots on the front shocks (#88100).
- Attach the cylinder end of the shock to the factory lower control arm mount using the factory hardware. The bolt should be installed from the rear. Do not tighten at this time.
- Place a washer and bushing half on the stem end of the shock and extend it through the upper shock mount

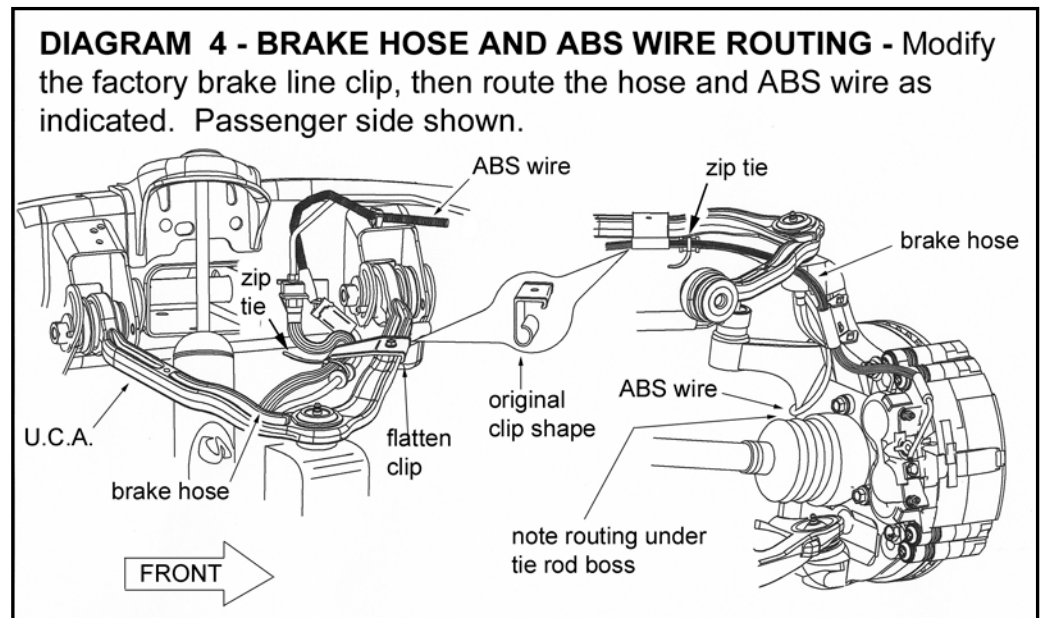

on the frame. Install the remaining bushing, washer, and nut, then tighten until the bushings swell slightly.

- Tighten the lower shock hardware (59).

24) TORSION BAR DROP BRACKETS...

- Slide the torsion bars into the lower control arms according to the marks made during removal. Slide them in far enough to not interfere with the crossmember installation.
- Install the bushing halves and sleeves in the torsion bar drop brackets (#55-12-3330) using a silicone-based grease.
- [DIAGRAM 5] Loosely install the "12" torsion bar brackets on the torsion bar crossmember using the factory hardware and test-fit the assembly on the frame. There are holes in the bottom of the drop brackets to provide clearance for the rivets retaining the original brackets in the frame. Using a straightedge or plumb bob, line up the crossmember mounting point on the "12" brackets with the mounting point on the originals.

- Due to variations in frame width, it may be necessary to space the drop brackets out slightly from the sides of the frame with the supplied extra-thick flat washers (up to two per side). Clamp each bracket firmly in place, then use a center punch to mark the location of the four holes to be drilled (two in the side of the frame and two in the bottom).

- Remove the bracket and drill the four holes just marked using a 29/64" drill bit. Clean up any burrs with a file.

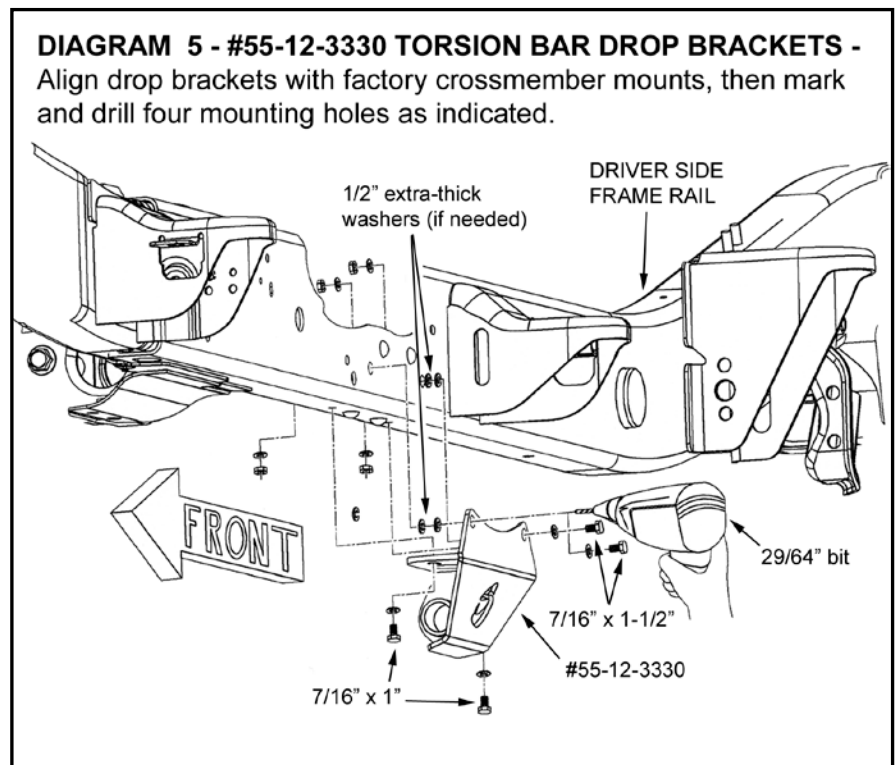

- Loosely attach the driver side torsion bar drop bracket to the frame using the supplied 7/16" x 1-1/2" bolts, extra-thick washers (if necessary), and nyloc nuts in the side of the frame, and the 7/16" x 1" bolts, washers, and nyloc nuts in the bottom of the frame. Do not fully tighten at this time.
- Loosely attach the passenger side drop bracket to the torsion bar crossmember using the factory hardware. Do not tighten at this time.
- Install and secure the torsion bar crossmember to the "12" driver side drop bracket. Secure the passenger side drop bracket to the side of the frame using the supplied 7/16" x 1-1/2" bolts, extra-thick washers (if necessary), and nyloc nuts, followed by the 7/16" x 1" bolts, washers, and nyloc nuts in the bottom of the frame.

- Tighten the 7/16" hardware (54) and the factory crossmember hardware (70).

25) TORSION BARS...

- Slide the bars forward enough to insert the torsion bar adjusting arms in the crossmember, then slide the bars back into the arms. Again, follow the indexing marks made during removal.

- Using the torsion bar puller tool, load the torsion bars enough to insert the adjusting bolt and nut block in the crossmember, then release the tension on the tool.

26) ANTI-SWAY BAR...

- [SWAY BAR LINK DIAGRAM] Install the "c" bracket (55-20-3370) using the supplied carriage bolt, placing a 'c' bracket on the sway bar body and one on the lower control arm in the orientation shown.

- Install the bushings and sleeves into the new sway bar link (55-21-3370). Install the link into the new 'c' bracket using the supplied hardware, as shown.

29) REAR LIFT...

NOTE: Rear lift is sold separately and includes separate instructions. In addition to the instructions for the rear lift, however, perform the following:

- Unbolt the rear compression travel stops from the frame. Bolt the factory travel stop to the Superlift drop bracket (55-19-3280) using the supplied 7/16" x 1" bolt and nyloc nut.
- Attach the compression travel stop assembly to the original location on the frame using the factory hardware and tighten.
- [DIAGRAM 9] Unbolt the rear brake line bracket from the top of the frame and carefully bend the factory steel brake line so that the bracket will reach the bottom of the frame as shown.
- Use the bracket as a template to mark the location of the two mounting holes, then slide the bracket aside and drill out the mark using a 1/4" bit.
- Attach the brake line bracket using the supplied 1/4" x 1" bolts and nyloc nuts and tighten (8). Verify the steel brake line does not touch or interfere with any other components.



- Remove the factory emergency brake cable brackets from the frame and attach the #55-26-3280 brackets to the frame using the factory hardware. Attach the factory cable brackets to the "26" brackets using the two supplied 3/8" x 1" bolts and nyloc nuts. Tighten (23).

WARNING: The vehicle is equipped with short cast spacer blocks located between the leaf springs and the axlehousing. These factory blocks must be retained because they seat properly against the axle mounts; the Superlift spacer blocks do not. When using Superlift blocks, install them on top of the factory blocks.

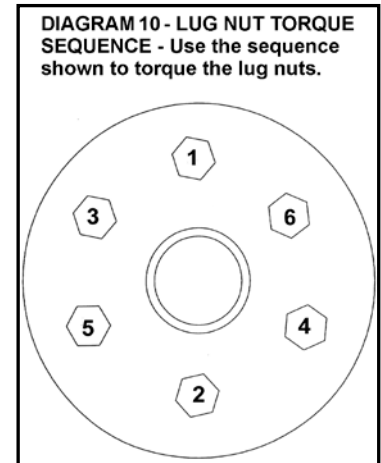

- Install the shocks using the factory hardware. On the lower mount, insert the supplied 1/2" flat washers between the shock bushing and the outside edge of the mount so that the shock is spaced inboard enough to clear the shock mount. Tighten the upper and lower mounts (100).

30) TIRES / WHEELS...

- [DIAGRAM 10] Tighten the lug nuts (140) in the sequence shown.

WARNING: When the tires / wheels are installed, always check for and remove any corrosion, dirt, or foreign material on the wheel mounting surface, or anything that contacts the wheel mounting surface (hub, rotor, etc.). Installing wheels without the proper metal-to-metal contact at the wheel mounting surfaces can cause the lug nuts to loosen and the wheel to come off while the vehicle is in motion.

WARNING: Retighten lug nuts at 500 miles after any wheel change, or anytime the lug nuts are loosened. Failure to do so could cause wheels to come off while vehicle is in motion.

31) CLEARANCE CHECK...

- With the vehicle still on jack stands, and the suspension "hanging" at full extension travel, cycle steering lock-to-lock and check all components for proper operation and clearances. Pay special attention to the clearance between the tires / wheels and brake hoses, wiring, etc.
- Lower vehicle to the floor.
- Reconnect the battery.

32) ADJUSTING FRONT RIDE HEIGHT...

- Manually bounce the front and rear of vehicle to normalize the torsion bars and leaf springs.
- On each side, fully tighten the LCA-to-crossmember bolts (107).

- [DIAGRAM 11] Position the vehicle on a level surface. Measure from the LCA front pivot bolt center down to the floor. Record this as Measurement "A".
- Now measure from the inside edge of the knuckle (at the lower ball joint boss) down to the floor. Record this as Measurement "B".

Subtract Measurement "B" from "A" for the ride height figure. Minimum ride height is 5.0"; maximum is 6.0". Ideal ride height is somewhere in between. Raise height by tightening the torsion bar adjusting bolt; lower height by loosening the bolt. It will be necessary to bounce the front of the vehicle every 1-2 turns of the adjusting bolt to reset the torsion bars. This will ensure accurate adjustments. Adjust height 3/8" to 1/2" above the final desired ride height, since the bars will settle slightly after the vehicle is driven.

NOTE: Exceeding the stated minimum or maximum heights will cause the suspension to continually "top out" or "bottom out". This results in a harsh ride, accelerated suspension component wear, and possibly component failure.

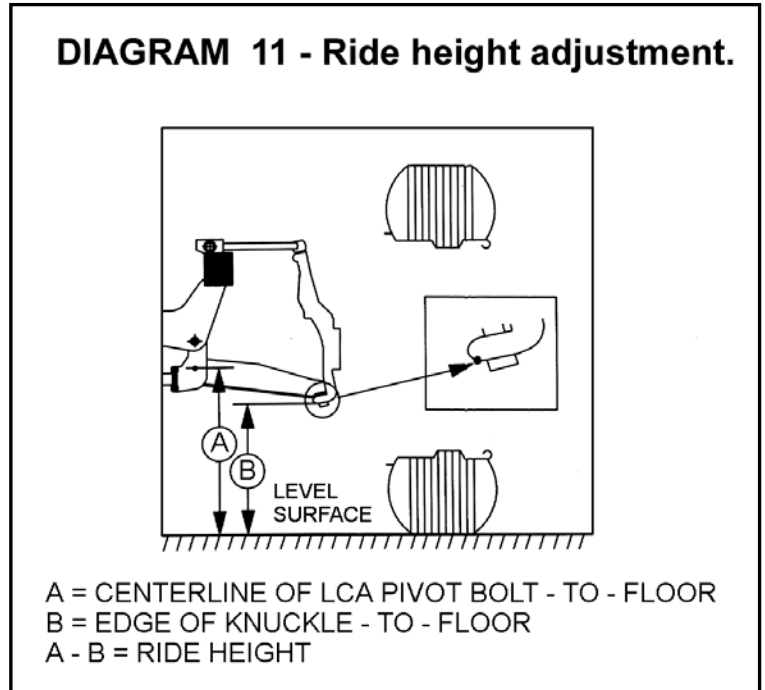

33) FINAL CLEARANCE and TORQUE CHECK...

- With vehicle on floor, cycle steering lock-to-lock and inspect the tires / wheels, and the steering, suspension, and brake systems for proper operation, tightness, and adequate clearance.

34) Activate four wheel drive system and check front hubs for engagement

35) HEADLIGHTS...

- Readjust headlights to proper setting.

36) SUPERLIFT WARNING DECAL...

- Install the WARNING TO DRIVER decal on the inside of the windshield, or on the dash, within driver's view. Refer to the "NOTICE TO DEALER AND VEHICLE OWNER" section below.

37) ALIGNMENT...

Realign vehicle to the specifications found in the factory service manual. Alignment must be performed by a certified professional. Record the ride height measurement at time of alignment. If, in the future the torsion bars settle excessively, alignment can be restored by adjusting-up the bars to their original ride height.