

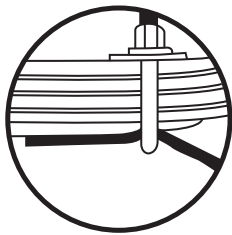

11-1010, 11-1020 3-WAY ADJUSTABLE LEAF HELPER SPRING INSTALLATION INSTRUCTIONS
WARNING - BEFORE INSTALLING, READ INSTRUCTIONS CAREFULLY. NOT FOLLOWING THESE INSTRUCTIONS MAY RESULT IN PROPERTY DAMAGES AND OR CAUSE SERIOUS INJURIES.

1. Determine load condition or height desired (refer to back panel on box or drawings below). The greatest load and height increase is possible when rivet (part 1) is in hole B. It is possible to secure more height increase by moving entire assembly back towards rear spring shackle.
2. Raise rear end of vehicle until wheels are clear of ground. Now see step 1.
3. After installing, check for clearance of all parts. Be sure U-Bolts and positioning clamps do not strike any portion of the undercarriage. If necessary use hack saw and cut off excess.



**LIGHT LOAD
POSITION 1**



**MEDIUM LOAD
POSITION 2**

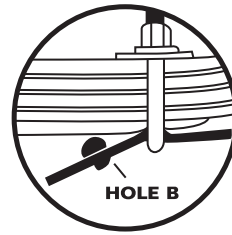

**HEAVY LOAD
POSITION 3**

IMPORTANT INSTRUCTIONS: Certain vehicles such as 1965 Ford Fairlane Wagons and others may have their gas tank in line with the U-Bolts after installation. In this case U-Bolt must be shortened, or installed in reverse from that shown above.

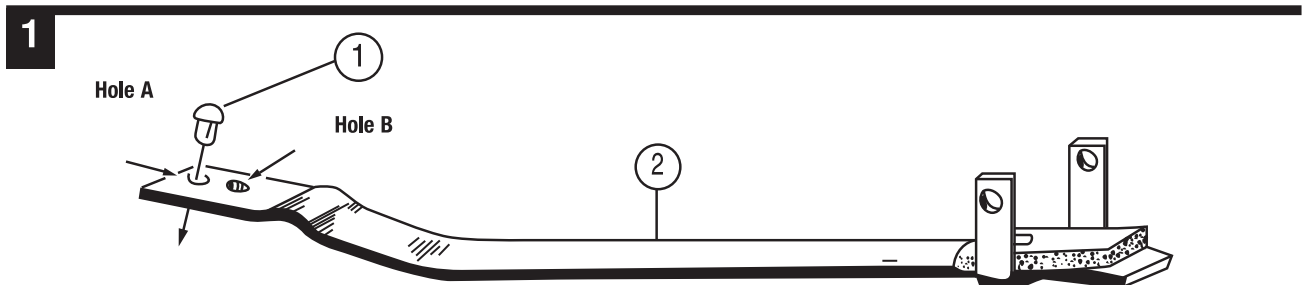





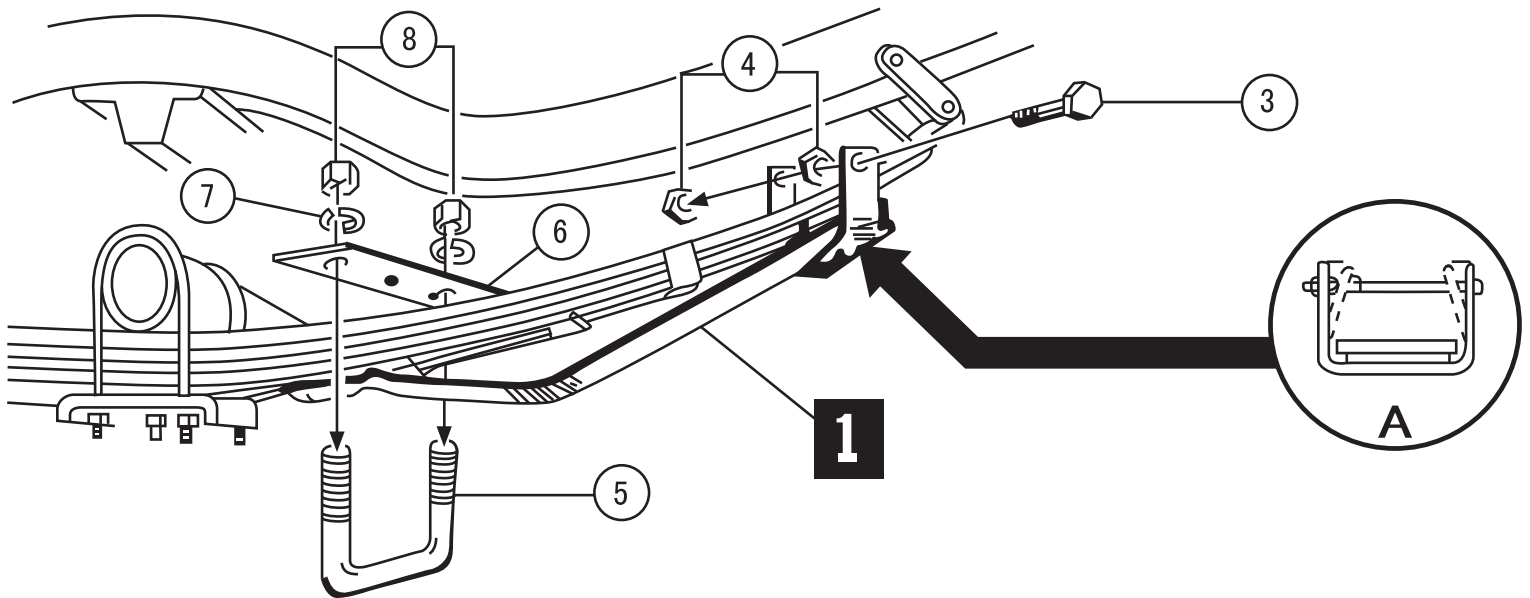

Place rivet Part 1 into hole A or B in part 2, depending on load condition desired. See above drawings for light, medium or heavy loads. **NOTE:** There is no rivet required in Position 1.

2

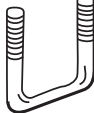
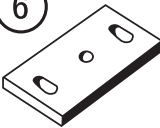

Place leaf spring assembly 1 under main spring by assembling Part 3 and (2) Parts 4 as shown. Next place Part 5 into recess area in Leaf Spring and slide Part 6 onto Part 5. Slide on (2) Parts 7 and screw on (2) Parts 8. Check to see that all fittings do not touch axle fittings and U-Bolt Part 5 in in the recess area in Leaf Spring then tighten all nuts securely. NOTE: FOR SPRINGS LESS THAN 2.5" WIDE, TIGHTEN LOC STRAP, AS SHOWN IN SMALL DRAWING A TO COMPENSATE FOR NARROW WIDTH SPRINGS.

 <p>5/16" RIVERT (2)</p>	 <p>LEAF (2)</p>	 <p>5/16 X 24 BOLT (2)</p>	 <p>5/16 NUT (4)</p>	 <p>U BOLT (4)</p>	 <p>CLAMP STRAP (2)</p>	 <p>LOCK WASHER (4)</p>	 <p>HEX. NUT (4)</p>
---	---	---	---	---	--	--	---



WARNING: This product contains chemicals known to the State of California to cause cancer and birth defects or other reproductive harm.

11-1030 / 11-1035 FULL -TIME OVER LEAF SPRING ASSIST INSTALLATION INSTRUCTIONS

WARNING - BEFORE INSTALLING, READ INSTRUCTIONS CAREFULLY. NOT FOLLOWING THESE INSTRUCTIONS MAY RESULT IN PROPERTY DAMAGES AND OR CAUSE SERIOUS INJURIES.

1. Place Leaf Helper Springs over rear portion of factory springs.
2. Install U-Bolts, Clamp Straps, Washers and Nuts.
3. Factory spring keepers may require bending or removing.
4. Tighten all nuts securely. Torque U-Bolts 75-85 Ft. lbs.
5. After installation, check for clearance of all parts. Be sure U-Bolts and clamps do not strike any portion of the undercarriage.
6. Install on metal leaf springs only. Do not install on composite springs. Do not install this product on electric or pneumatic assisted suspension systems.
7. Check and tighten nuts after 50 miles.

DO NOT EXCEED MANUFACTURER'S MAXIMUM GROSS VEHICLE WEIGHT RATING (M.G.V.W.R.)

11-1030 - Increase level load-carrying capacity by 1,000 lbs. with one pair, or by 1,500 lbs. or more with 2 pairs. (sold separately).

11-1035 - Increase level load-carrying capacity by 1,500 lbs. with one pair, or by 2,000 lbs. or more with 2 pairs. (sold separately).

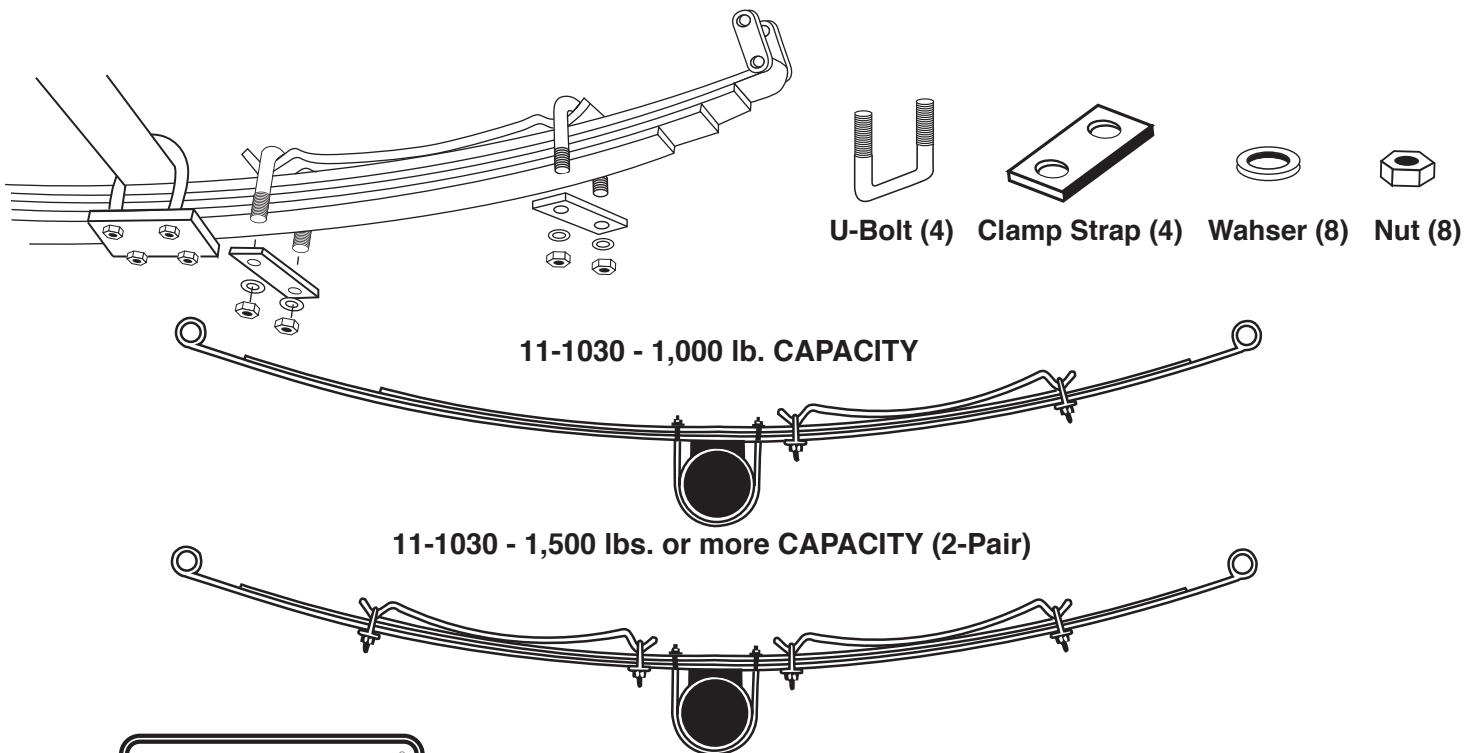

WARNING: This product contains chemicals known to the State of California to cause cancer and birth defects or other reproductive harm.

11-1040 HEAVY DUTY 2,000 LB. LEAF HELPER SPRING INSTALLATION INSTRUCTIONS
WARNING - BEFORE INSTALLING, READ INSTRUCTIONS CAREFULLY. NOT FOLLOWING THESE INSTRUCTIONS MAY RESULT IN PROPERTY DAMAGES AND OR CAUSE SERIOUS INJURIES.

1. Jack up car by the frame or bumper, approximately 6" higher than the ultimate height desired.
2. Place special U-Bolts over top of stock springs and position Superleaf spring helper under present spring and saddle. (See Figure 1).
3. Install plates, lock washers and nuts, tightening securely.
4. Alternate installation: remove present spring saddle and install the Superleaf spring helper directly against bottom of stock spring. Replace saddle plates and install special U-Bolts as above. Check and retighten nuts after 50 miles. Drill center in Superleaf spring helper if required to accommodate spring bolt.
5. Additional load capacity may be obtained without raising vehicle by installing Superleaf without jacking up car.
6. Positioning Superleaf towards the rear of the car will provide maximum load capacity and height. For pickup trucks with springs mounted on top of the axle housing. Superleaf may be mounted on some models between the spring and the axle, however, sufficient U-Bolt length must be checked and a center hole must be provided to assure that the spring center bolt protrudes through the Superleaf into the axle housing spring mount.

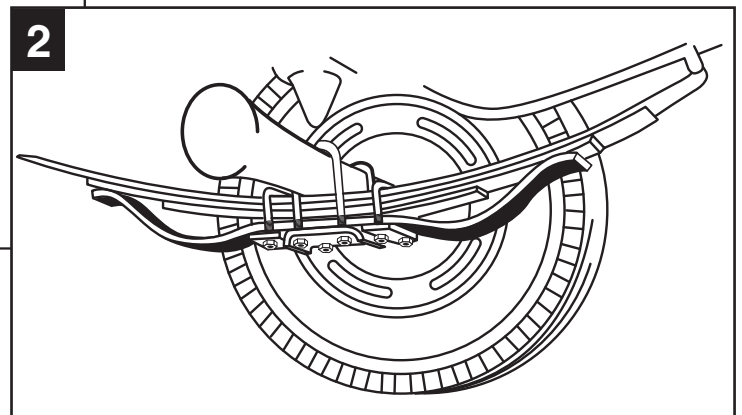
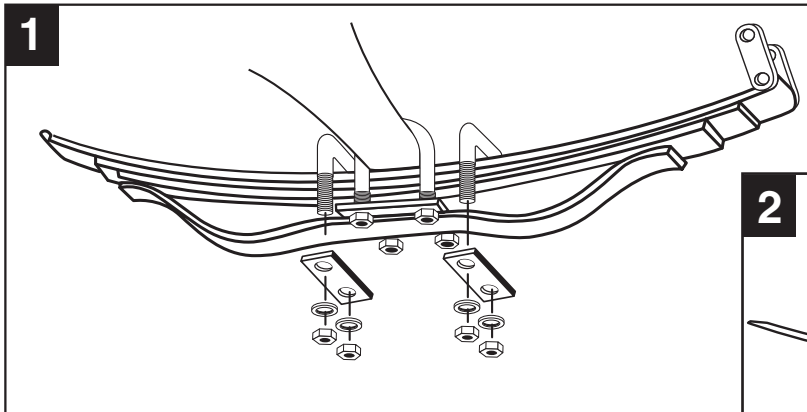

WARNING: This product contains chemicals known to the State of California to cause cancer and birth defects or other reproductive harm.