



### ⚠ WARNING



**ALWAYS READ INSTRUCTIONS BEFORE USING POWER TOOLS**



**ALWAYS WEAR SAFETY GOGGLES**



**WEAR HEARING PROTECTION**



**AVOID PROLONGED EXPOSURE TO VIBRATION**



**RPM OF CUTTING WHEEL MUST MEET OR EXCEED RPM OF TOOL (20,000 RPM)**

### ⚠ WARNING

Some dust created by power sanding, sawing, grinding, drilling, and other construction activities contains chemicals known to cause cancer, birth defects or other reproductive harm. Some examples of these chemicals are:

- lead from lead-based paints,
- crystalline silica from bricks and cement and other masonry products, and
- arsenic and chromium from chemically-treated lumber.

Your risk from these exposures varies, depending on how often you do this type of work. To reduce your exposure to these chemicals: work in a well ventilated area, and work with approved safety equipment, such as those dust masks that are specially designed to filter out microscopic particles.

### SPECIFICATIONS

Max. Free Speed .....	20,000 RPM	Air Inlet.....	1/4" NPT
Wheel Size .....	3"	Recommended Air Pressure.....	90 PSI
Weight.....	1.6 LB	Sound Level.....	93 dBA
Length .....	7.83"	Air Supply Hose Size.....	3/8" I.D.
Average Air Consumption.....	5 CFM		

**SX233A**  
UTILITY  
CUT-OFF  
TOOL

# ! WARNING

## FAILURE TO OBSERVE THESE WARNINGS COULD RESULT IN INJURY.

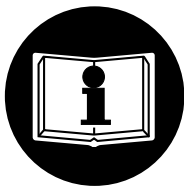

**This Instruction Manual Contains Important Safety Information.**

**READ THIS INSTRUCTION MANUAL CAREFULLY AND UNDERSTAND ALL INFORMATION BEFORE OPERATING THIS TOOL.**

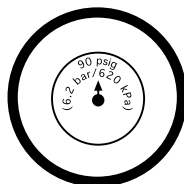

• Always operate, inspect and maintain this tool in accordance with American National Standards Institute Safety Code of Portable Air Tools (ANSI B186.1) and any other applicable safety codes and regulations.

• For safety, top performance and maximum durability of parts, operate this tool at 90 psig/6.2 bar max air pressure with 3/8" diameter air supply hose.



• Always wear impact-resistant eye protection when operating or performing maintenance on this tool.

• High sound levels can cause permanent hearing loss. Always use hearing protection as recommended by your employer or OSHA regulation.



• Keep the tool in efficient operating condition.

• Operators and maintenance personnel must be physically able to handle the bulk, weight and power of this tool.

• Air under pressure can cause severe injury. Never direct air at yourself or others. Always turn off the air supply, drain hose of air pressure and detach tool from air supply before installing, removing or adjusting any accessory on this tool, or before performing any maintenance on this tool. Failure to do so could result in injury. Always check for damaged, frayed or loose hoses and fittings, and replace immediately. Do not use quick detach couplings at tool. See instructions for correct set-up.

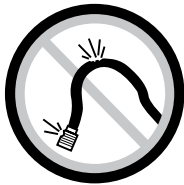
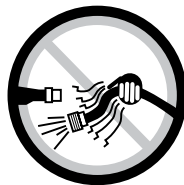

• Air powered tools can vibrate in use. Vibration, repetitive motions or uncomfortable positions over extended periods of time may be harmful to your hands and arms. Discontinue use of tool if discomfort, tingling feeling or pain occurs. Seek medical advice before resuming use.



• Place the tool on the work before starting the tool. Do not point or indulge in any horseplay with this tool.

• Slipping, tripping and/or falling while operating air tools can be a major cause

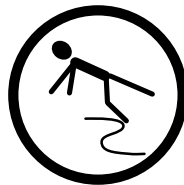

of serious injury or death. Be aware of excess hose left on the walking or work surface.

• Keep body working stance balanced and firm. Do not overreach when operating the tool.

• Anticipate and be alert for sudden changes in motion during start up and operation of any power tool.

• Do not carry tool by the hose. Protect the hose from sharp objects and heat.

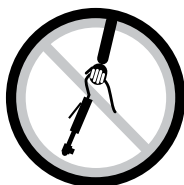

• Tool shaft may continue to rotate briefly after throttle is released. Avoid direct contact with accessories during and after use. Gloves will reduce the risk of cuts or burns.

• Keep away from rotating end of tool. Do not wear jewelry or loose clothing. Secure long hair. Scalping can occur if hair is not kept away from tool and accessories. Choking can occur if neckwear is not kept away from tool and accessories.



• Correct grinding wheel mounting is necessary to prevent injury from broken wheels. Do not use chipped or cracked grinding wheels. Grinding wheels should be a free fit on the spindle to prevent stress at the hole. Use only wheel collars that come with the grinder for mounting the grinding wheel. Flat washers or other adapters may over stress the wheel. Always use heavy paper blotter discs between the wheel collars and the grinding wheel. Tighten the wheel on the spindle to prevent spin off when the air grinder is turned off.

• Do not lubricate tools with flammable or volatile liquids such as kerosene, diesel or jet fuel.

• Do not force tool beyond its rated capacity.

• Do not remove any labels. Replace any damaged labels.

• Use accessories recommended by Sunex Tools®.

# SX233A

## UTILITY CUT-OFF TOOL

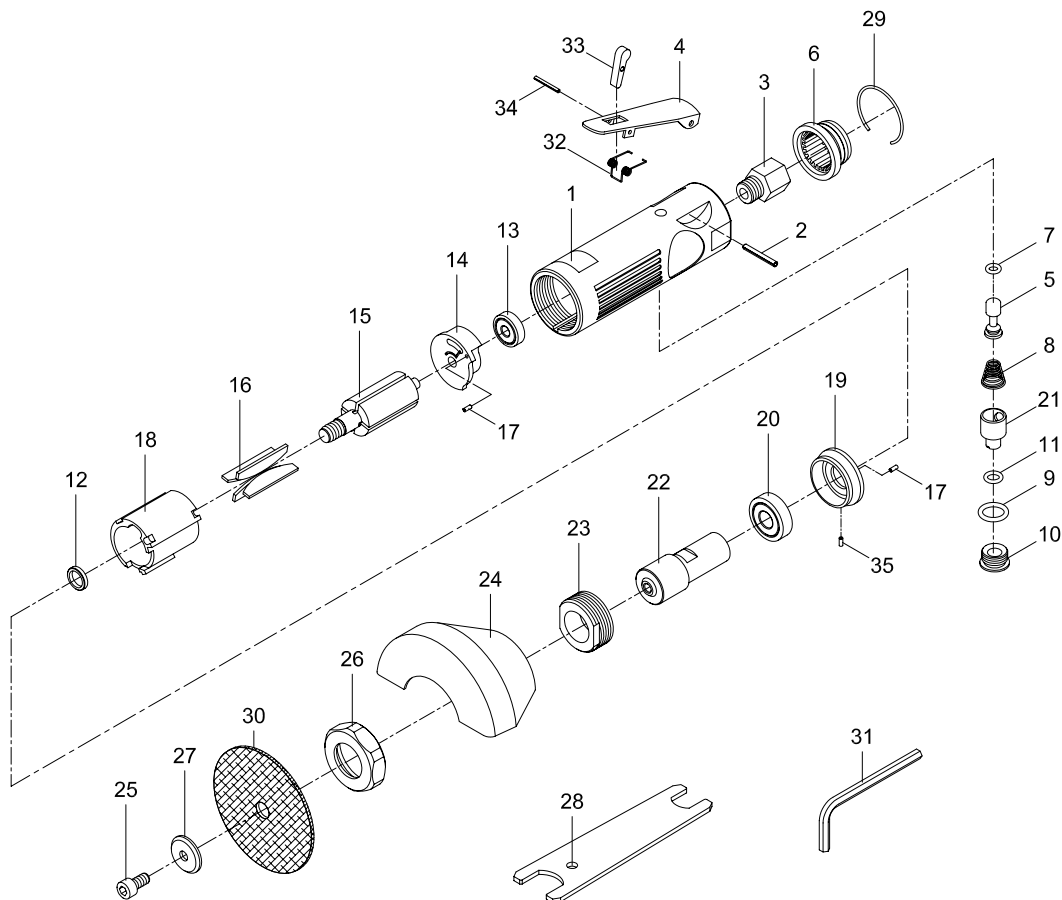

REF. NO.	PART NO.	DESCRIPTION	QTY.
1	RS380101	Motor Housing	1
2	RS233A02	Lever Pin	1
3	RS233A03	Air Inlet	1
4	RS380104	Throttle Lever	1
5	RS233A05	Valve Stem	1
6	RS233A06	Exhaust Deflector	1
7	RS233A07	O-Ring	1
8	RS233A08	Valve Spring	1
9	RS233A09	O-Ring	1
10	RS233A10	Throttle Valve Plug	1
11	RS233A11	O-Ring	1
12	RS233A12	Rotor Bushing	1
13	RS21114	Ball Bearing	1
14	RS233A14	Rear End Plate	1
15	RS233A15	Rotor	1
16	RS233A16	Rotor Blade	4
17	RS233A17	Pin	3

REF. NO.	PART NO.	DESCRIPTION	QTY.
18	RS380118	Cylinder	1
19	RS233A19	Front End Plate	1
20	RS10920	Ball Bearing	1
21	RS233A21	Air Regulator	1
22	RS233A22	Spindle	1
23	RS233A23	Retainer	1
24	RS233A24	Guard	1
25	RS233A25	Hex Screw	1
26	RS233A26	Nut	1
27	RS233A27	Washer	1
28	RS233A28	Spanner	1
29	RS233A29	Retainer Ring	1
*30	87602	Cutting Wheel (pkg. of 5)	1
31	RS233A31	Allen Wrench	1
32	RS380132	Spring	1
33	RS380133	Safety Bar	1
34	RS380134	Spring Pin	1

\*Replacement cutting wheels are sold only in packs of 5.

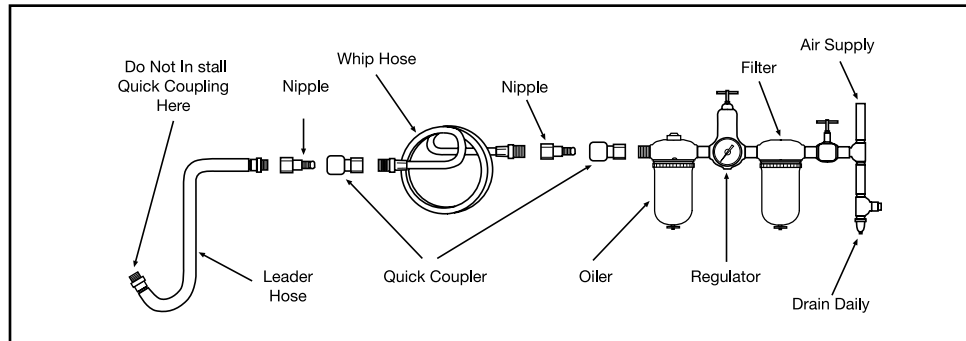

### Air Supply...

Tools of this class operate on a wide range of air pressures. It is recommended that air pressure of these tools measures 90 PSI at the tool while running free. Higher pressure (over 90 psig; 6.2 bar) raises performance beyond the rated capacity of the tool which will shorten tool life because of faster wear and could cause injury.

Always use clean, dry air. Dust, corrosive fumes and/or water in the air line will cause damage to the tool. Drain the air tank daily. Clean the air inlet filter screen on at least a weekly schedule. The recommended hookup procedure can be viewed in figure 1.

### Lubrication...

Lubricate the air motor daily with quality air tool oil. If no air line oiler is used, run 1/2 ounce of air tool oil through the tool by squirting oil into the tool's air inlet or into the nearest connection to the air inlet, reconnecting air supply, and then running tool. Do not use more than 1/2 ounce of oil, as overfilling will reduce the performance of the tool.

### Troubleshooting...

Other factors outside the tool may cause loss of power or erratic action. Reduced compressor output, excessive drain on the air line, moisture or restrictions in air pipes or the use of hose connections of improper size or poor conditions may reduce air supply. Grit or gum deposits in the tool may cut power and may be corrected by cleaning the air strainer and flushing out the tool with gum solvent oil or an equal mixture of SAE #10 and kerosene. If outside conditions are in order, disconnect tool from hose and take tool to your nearest authorized service center.

### Operation...

Let the tool do the work. Do not put extreme pressure on the machine. This will only slow down the speed of the cutting wheel, reduce cutting efficiency, and put an additional burden on the motor. Start the tool off the work, set it down on the work evenly and move in the direction desired to make the cut. When finished cutting, lift off the work before stopping the motor.

NOTE: During operation, safety goggles should always be worn to guard against flying rust and chips. Use only wheels rated at 20,000 RPM or higher.