

MANUAL

CONTENTS:

Page	1	Specifications
	2	Warning Information (Service Jack)
	3	Warning Information (Jack Stands)
	4	Setup Instructions and Operating Instructions
	5	Preventative Maintenance, Inspection, Proper Storage and Troubleshooting
	6	Owner/User Responsibility and Warranty Information
	7	Hydraulic Jack Maintenance Guide and Regular Maintenance
	8	Exploded View Drawing and Replacement Parts (Service Jack)
	9	Exploded View Drawing and Replacement Parts (Jack Stands)

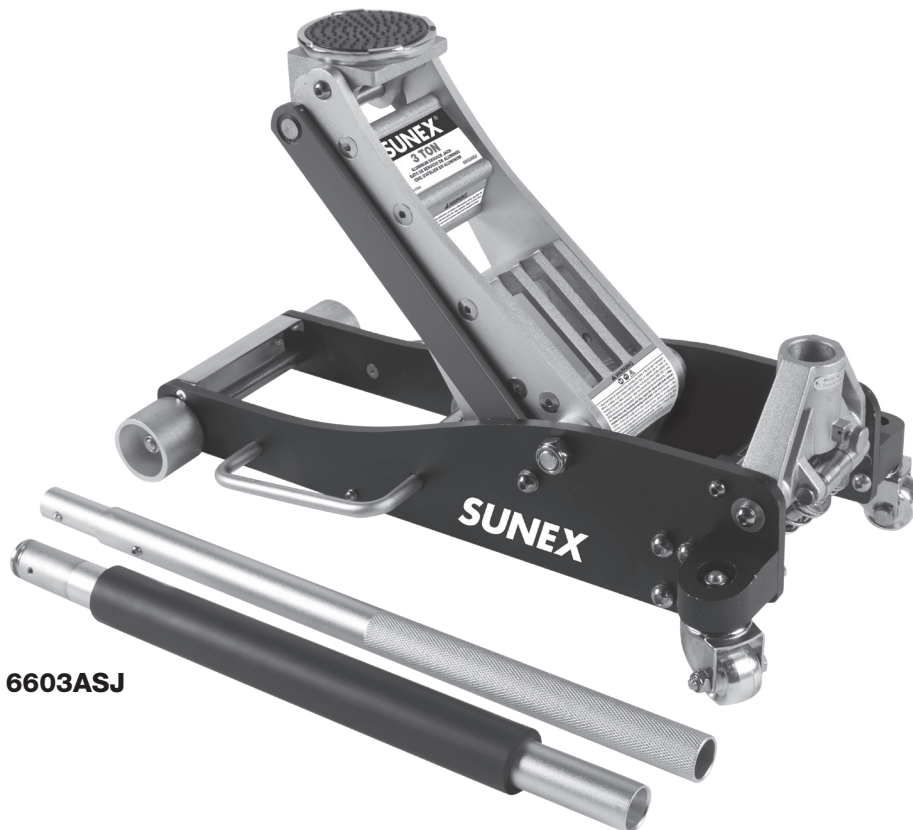

6603ASJ



1003AJ

SERVICE JACK SPECIFICATIONS

6603ASJ	
Capacity.....	3 Ton
Low Height.....	3.8"
High Height.....	19.3"
Chassis Length.....	26.4"
Overall Width.....	13"
Handle Length.....	47.6"
Saddle Diameter.....	4.5"
Shipping Weight.....	58.4 lbs.

JACK STAND SPECIFICATIONS

1003AJ	
Capacity.....	3 Ton
Low Height.....	10.6"
High Height.....	15.4"
Saddle Size.....	2.2" x 2"
Base Diameter.....	7.1"
Shipping Weight (pair).....	10 lbs.

Complies with ASME PASE-2014 Safety Standard

WARNING INFORMATION - FLOOR SERVICE JACK



This is the safety alert symbol. It is used to alert you to potential personal injury hazards. Obey all safety messages that follow this symbol to avoid possible injury or death.

WARNING

WARNING: Indicates a hazardous situation which, if not avoided, could result in death or serious injury.



IMPORTANT: READ THESE INSTRUCTIONS BEFORE OPERATING

BEFORE USING THIS DEVICE, READ THIS MANUAL COMPLETELY AND THOROUGHLY, UNDERSTAND ITS OPERATING PROCEDURES, SAFETY WARNINGS AND MAINTENANCE REQUIREMENTS.

It is the responsibility of the owner to make sure all personnel read this manual prior to using the device. It is also the responsibility of the device owner to keep this manual intact and in a convenient location for all to see and read. If the manual or product labels are lost or not legible, contact Sunex for replacements. If the operator is not fluent in English, the product and safety instructions shall be read to and discussed with the operator in the operator's native language by the purchaser/owner or his designee, making sure that the operator comprehends its contents.















THE NATURE OF HAZARDOUS SITUATIONS

WARNING

The use of portable automotive lifting devices is subject to certain hazards that cannot be prevented by mechanical means, but only by the exercise of intelligence, care, and common sense. It is therefore essential to have owners and personnel involved in the use and operation of the equipment who are careful, competent, trained, and qualified in the safe operation of the equipment and its proper use. Examples of hazards are dropping, tipping or slipping of loads caused primarily by improperly securing loads, overloading, off-centered loads, use on other than hard level surfaces, and using equipment for a purpose for which it was not designed.

METHODS TO AVOID HAZARDOUS SITUATIONS

WARNING

-  Read, study, understand and follow all instructions before operating this device.
-  Inspect the jack before each use. Do not use jack if damaged, altered, modified, in poor condition, leaking hydraulic fluid, or unstable due to loose or missing components. Make corrections before using.
-  Lift only on areas of the vehicle as specified by the vehicle manufacturer.
-  Wear eye protection that meets ANSI Z87.1 and OSHA standards (users and bystanders).
-  Do not use jack beyond its rated capacity. Do not shock Load.
-  **This is a lifting device only. Immediately after lifting, support the vehicle with jack stands capable of sustaining the load before working on the vehicle.**
-  Use only on a hard level surface free from obstructions so the jack is free to reposition itself during lifting and lowering operations.
-  Center load on saddle. Be sure setup is stable before working on vehicle.
-  Do not move or dolly the vehicle while on the jack.
-  Do not use any materials that may serve as risers, spacers or extenders between the stock lifting saddle and the load.
-  Do not use any adapters that replace the stock lifting saddle unless approved or supplied by the jack manufacturer.
-  Do not use (or modify) this product for any other purpose than that for which it was designed without consulting the manufacturer's authorized representative.
-  Always lower the jack slowly and carefully.
-  Failure to heed these warnings may result in serious or fatal personal injury and/or property damage.

 **WARNING:** This product can expose you to chemicals including nickel, which is known to the State of California to cause cancer and birth defects or other reproductive harm.

CONSEQUENCES OF NOT AVOIDING HAZARDOUS SITUATIONS

WARNING

Failure to read this manual completely and thoroughly, failure to understand its OPERATING INSTRUCTIONS, SAFETY WARNINGS, MAINTENANCE INSTRUCTIONS and comply with them, and failure to comply with the METHODS TO AVOID HAZARDOUS SITUATIONS could cause accidents resulting in serious or fatal personal injury and/or property damage.

WARNING INFORMATION - JACK STANDS



This is the safety alert symbol. It is used to alert you to potential personal injury hazards. Obey all safety messages that follow this symbol to avoid possible injury or death.

WARNING

WARNING: Indicates a hazardous situation which, if not avoided, could result in death or serious injury.



IMPORTANT: READ THESE INSTRUCTIONS BEFORE OPERATING

BEFORE USING THIS DEVICE, READ THIS MANUAL COMPLETELY AND THOROUGHLY, UNDERSTAND ITS OPERATING PROCEDURES, SAFETY WARNINGS AND MAINTENANCE REQUIREMENTS.

It is the responsibility of the owner to make sure all personnel read this manual prior to using the device. It is also the responsibility of the device owner to keep this manual intact and in a convenient location for all to see and read. If the manual or product labels are lost or not legible, contact Sunex for replacements. If the operator is not fluent in English, the product and safety instructions shall be read to and discussed with the operator in the operator's native language by the purchaser/owner or his designee, making sure that the operator comprehends its contents.



















THE NATURE OF HAZARDOUS SITUATIONS

WARNING

The use of portable automotive lifting devices is subject to certain hazards that cannot be prevented by mechanical means, but only by the exercise of intelligence, care, and common sense. It is therefore essential to have owners and personnel involved in the use and operation of the equipment who are careful, competent, trained, and qualified in the safe operation of the equipment and its proper use. Examples of hazards are dropping, tipping or slipping of loads caused primarily by improperly securing loads, overloading, off-centered loads, use on other than hard level surfaces, and using equipment for a purpose for which it was not designed.

METHODS TO AVOID HAZARDOUS SITUATIONS

WARNING

-  • Read, study, understand and follow all instructions before operating this device.
-  • Inspect the jack stands before each use. Do not use jack stands if damaged, altered, modified, in poor condition, or unstable due to loose or missing components. Make corrections before using.
-  • Wear eye protection that meets ANSI Z87.1 and OSHA standards (users and bystanders).
-  • Do not use jack stands beyond the pair's rated capacity. Do not shock load.
-  • **Do not crawl under the vehicle while lifting vehicle or placing or removing the jack stands.**
-  • Use as a matched pair only.
-  • Maximum load capacity per matched pair shall not exceed the rated capacity of the individual stand.
-  • Use only on a hard level surface capable of supporting the load.
-  • Stands are to be used in matched pairs to support one end of a vehicle only. Do not simultaneously support both ends or one side of a vehicle.
-  • Apply the emergency brake and put the gear shift lever in park or in gear if a manual shift transmission, and chock the tires that will not be lifted off the ground.
-  • Ensure both stands are set at same height and locking pins are fully engaged.
-  • Check the stands for solid contact with the ground and vehicle.
-  • Never use the stand's lower support plate (if so equipped) as a load bearing surface for the locking pin.
-  • Consult the vehicle manufacturer for the proper frame support locations.
-  • Center load on saddle. Do not use saddle lugs to support the load.
-  • Make sure the stand's locking pins are fully engaging the stand on both sides and the support column saddle is making contact with a vehicle support surface that can support the load.
-  • Do not use (or modify) this product for any other purpose than that for which it was designed without consulting the manufacturer's authorized representative.
-  • Failure to heed these warnings may result in serious or fatal personal injury and/or property damage.

 **WARNING:** This product can expose you to chemicals including nickel, which is known to the State of California to cause cancer and birth defects or other reproductive harm.

CONSEQUENCES OF NOT AVOIDING HAZARDOUS SITUATIONS

WARNING

Failure to read this manual completely and thoroughly, failure to understand its OPERATING INSTRUCTIONS, SAFETY WARNINGS, MAINTENANCE INSTRUCTIONS and comply with them, and failure to comply with the METHODS TO AVOID HAZARDOUS SITUATIONS could cause accidents resulting in serious or fatal personal injury and/or property damage.

OWNER'S MANUAL

JACK STAND ASSEMBLY INSTRUCTIONS

1. Install the support column (#3) into the stand base (#2), align the holes in the stand base (#2) with the holes at the bottom of the support column (#3).
2. Install the bolt (#1) through the stand base (#2) and support column (#3) and thread the nut (#4) onto the bolt (#1) and tighten.
3. Place the saddle column (#8) into the support column (#3).

JACK SETUP

PLEASE REFER TO THE EXPLODED VIEW DRAWING IN THIS MANUAL IN ORDER TO IDENTIFY PARTS.

1. The saddle (#3) should be in its lowest position. Remove the oil filler plug in the reservoir of the hydraulic power unit (#29).
2. Look inside the oil fill plug hole. You should be able to see the top of the power unit's cylinder. The hydraulic fluid level should be no higher than the top of the cylinder. Correct the fluid level if it is not at the proper height. **CAUTION:** In order to prevent seal damage and jack failure, never use alcohol, hydraulic brake fluid, or transmission oil in the jack. Use hydraulic jack oil, a light turbine oil, Chevron Hydraulic Oil AW ISO 32 or Unocal Unax AW 150.
3. Close the release valve by turning the handle (#26) clockwise until it stops. Pump the jack against a load of at least 500 pounds (225 Kgs). After the load is raised to maximum height, slightly turn the handle (#26) in a counterclockwise direction so the load is very slowly lowered, while simultaneously and quickly pumping the handle 5 or 6 full incremental pump strokes. After pumping, lower the lift arm to its full rest position.
4. Repeat steps 3) through 4) until all the air has been purged from the system. Reinstall the cover plate.

OPERATING INSTRUCTIONS



This is the safety alert symbol used for the OPERATING INSTRUCTIONS section of this manual to alert you to potential personal injury hazards. Obey all instructions to avoid possible injury or death.

IMPORTANT: Before attempting to raise any vehicle, check vehicle service manual for recommended lifting surfaces.

JACK STAND OPERATION:

1. Make sure the work floor is clean and free of debris and obstacles.
2. Chock the vehicle's tires that will not be lifted. Make sure the emergency brake is on and the vehicle's transmission is either in the park mode or in gear if a manual transmission.
3. Raise the vehicle to a safe working height and make sure the jack and vehicle setup are stable before positioning the jack stands. **DO NOT CRAWL UNDER THE VEHICLE TO POSITION OR REMOVE STANDS.**
4. Position the jack stands right below the areas of the vehicle support points as specified by the vehicle manufacturer.
5. Lift the saddle columns as close to the vehicle as possible without the saddles on the columns coming in contact with the vehicle. Insert the locking pin.
6. Slowly and carefully lower the vehicle on the jack stands. Shock loads or loads dropped abruptly on stands can cause premature metal fatigue or even stand failure depending on the weight of the vehicle and the speed of decent that impacts the stands' support columns. The load should be supported in the center of the support column saddles, not the locating lugs of the saddles.
7. Check the load for stability. If the load is not stable, lift the load off the stands and correctly reposition the stands.
8. When work is completed, raise the vehicle high enough off the stands where the stands can be easily removed.

JACK OPERATION:

1. **To raise load:** Turn the handle in a clockwise direction until tight. Position the jack under the load. Proceed to pump the handle in order to raise the lift arm to the load. As the saddle at the end of the lift arm gets closer to the load, reposition the jack so the saddle will contact the load firmly and the load is centered on the saddle. Make sure the saddle is correctly positioned. Raise the load to the desired work height. Place jack stands of appropriate capacity at the vehicle manufacturers's recommended support areas that provide stable support for the raised vehicle. **DO NOT CRAWL UNDER VEHICLE WHILE LIFTING VEHICLE OR PLACING OR REMOVING THE JACK STANDS!** Once jack stands are positioned, turn the handle VERY SLOWLY. Lower the load to rest on the jack stands. Inspect the relationship between the jack stands and load to make sure the setup is stable and safe. If the setup is not stable or safe, follow the preceding steps until corrected.
2. **To lower load:** Follow the procedures mentioned in "To raise load" section of the OPERATING INSTRUCTIONS in order to raise the load off the jack stands. Once the load has cleared the jack stands, remove the jack stands from under the load and away from the work area. Turn handle very slowly in a counterclockwise direction until the load is completely lowered to the ground. Once the jack's lifting saddle has cleared the load, remove the jack from under the load. **CAUTION:** Keep hands and feet away from the hinge mechanism of the jack. **DO NOT CRAWL UNDER VEHICLE WHILE LIFTING VEHICLE OR PLACING OR REMOVING THE JACK STANDS!**

OWNER'S MANUAL

PREVENTATIVE MAINTENANCE



This is the safety alert symbol used for the PREVENTATIVE MAINTENANCE section of this manual to alert you to potential personal injury hazards. Obey all instructions to avoid possible injury or death.

1. Always store the jack and jack stands in a well protected area where they will not be exposed to inclement weather, corrosive vapors, abrasive dust, or any other harmful elements. The jack and jack stands must be cleaned of water, snow, sand, grit, oil, grease or other foreign matter before using.
2. The jack must be lubricated periodically in order to prevent premature wearing of parts. A general purpose grease must be applied to all zerk grease fittings, caster wheels, front axle, lift arm, handle base pivot bolts, release mechanism and all other bearing surfaces. Worn parts resulting from inadequate or no lubrication are not eligible for warranty consideration.
3. It should not be necessary to refill or top off the reservoir with hydraulic fluid unless there is an external leak. An external leak requires immediate repair which must be performed in a dirt-free environment by an authorized service center.

IMPORTANT: In order to prevent seal damage and jack failure, never use alcohol, hydraulic brake fluid or transmission oil in the jack. Use Chevron Hydraulic Oil AW ISO 32 or its equivalent Unocal Unax AW 150.

4. Every jack and jack stand owner is responsible for keeping the jack labels clean and readable. Use a mild soap solution to wash external surfaces of the jack but not any moving hydraulic components.
5. Inspect the jack and jack stands before each use. Do not use the jack and jack stands if any component is cracked, broken, bent, shows sign of damage or leaks hydraulic fluid. Do not use the jack if it has loose or missing hardware or components, or is modified in any way. Take corrective action before using the jack again.
6. Any hydraulic repairs within the warranty period must be performed by an authorized service center.

INSPECTION

Visual inspection should be made before each use of the jack and stands, checking for leaking hydraulic fluid and damaged, loose or missing parts. Jack and stands must be inspected by a manufacturer's repair facility immediately if subjected to an abnormal load or shock. Any jack or stands which appear to be damaged in any way, are found to be badly worn, or operate abnormally **MUST BE REMOVED FROM SERVICE** until necessary repairs are made by a manufacturer's authorized repair facility. It is recommended that an annual inspection of the jack and stands be made by a manufacturer's authorized repair facility and that any defective parts, decals or warning labels be replaced with manufacturer's specified parts. A list of authorized repair facilities is available from the manufacturer.

PROPER STORAGE

It is recommended that the jack and jack stands be stored in a dry location with all wheels and stand legs touching the ground on a relatively level surface.

TROUBLESHOOTING

Important: Service jacks are self-contained devices used for lifting, but not sustaining, a partial vehicular load. In accordance with ASME-PASE Load Sustaining Test: "A load not less than the rated capacity...shall not lower more than 1/8" (3.18mm) in the first minute, nor a total of .1875" (4.76mm) in 10 minutes." Lowering within this range is considered normal operation and is NOT a warrantable defect.

PROBLEM	ACTION
1. Unit will not lift rated load.	Purge air from hydraulic system by following procedure under SETUP.
2. Unit will not sustain rated load or feels "spongy" under rated load.	Purge air from hydraulic system as above.
3. Unit will not lift to full height.	Purge air from hydraulic system as above.
4. Handle tends to raise up while the unit is under rated load.	Pump the handle rapidly several times to push oil past ball valves in power unit.
5. Unit still does not operate.	Contact Sunex authorized hydraulic service center.

OWNER'S MANUAL

OWNER/USER RESPONSIBILITY

The owner and/or user must have an understanding of the manufacturer's operating instructions and warnings before using this jack. Personnel involved in the use and operation of equipment shall be careful, competent, trained, and qualified in the safe operation of the equipment and its proper use when servicing motor vehicles and their components. Warning information should be emphasized and understood. If the operator is not fluent in English, the manufacturer's instructions and warning shall be read to and discussed with the operator in the operator's native language by the purchaser/owner, making sure that the operator comprehends its contents. Owner and/or user must study and maintain for future reference the manufacturers' instructions. Owner and/or user is responsible for keeping all warning labels and instruction manuals legible and intact. Replacement labels and literature are available from the manufacturer.

HYDRAULIC MAINTENANCE GUIDE

IMPORTANT: Service jacks are designed for lifting purposes only; always support raised load with jack stands.

REGULAR MAINTENANCE

• **MONTHLY or as necessary (depending on usage)**

1. Using a grease gun, add grease to grease fitting in the lift arm pivot shaft.
(Use a multi-purpose NLGI type grease only.)
2. Lubricate all linkages and pivot points.
(Use white lithium spray grease only.)
3. Remove handle; lubricate handle receptacle and handle end.
(Use white lithium spray grease only.)
4. Lubricate both rear casters, bearing and both front wheels.
(Use white lithium spray grease only.)
5. Tighten all accessible hardware.

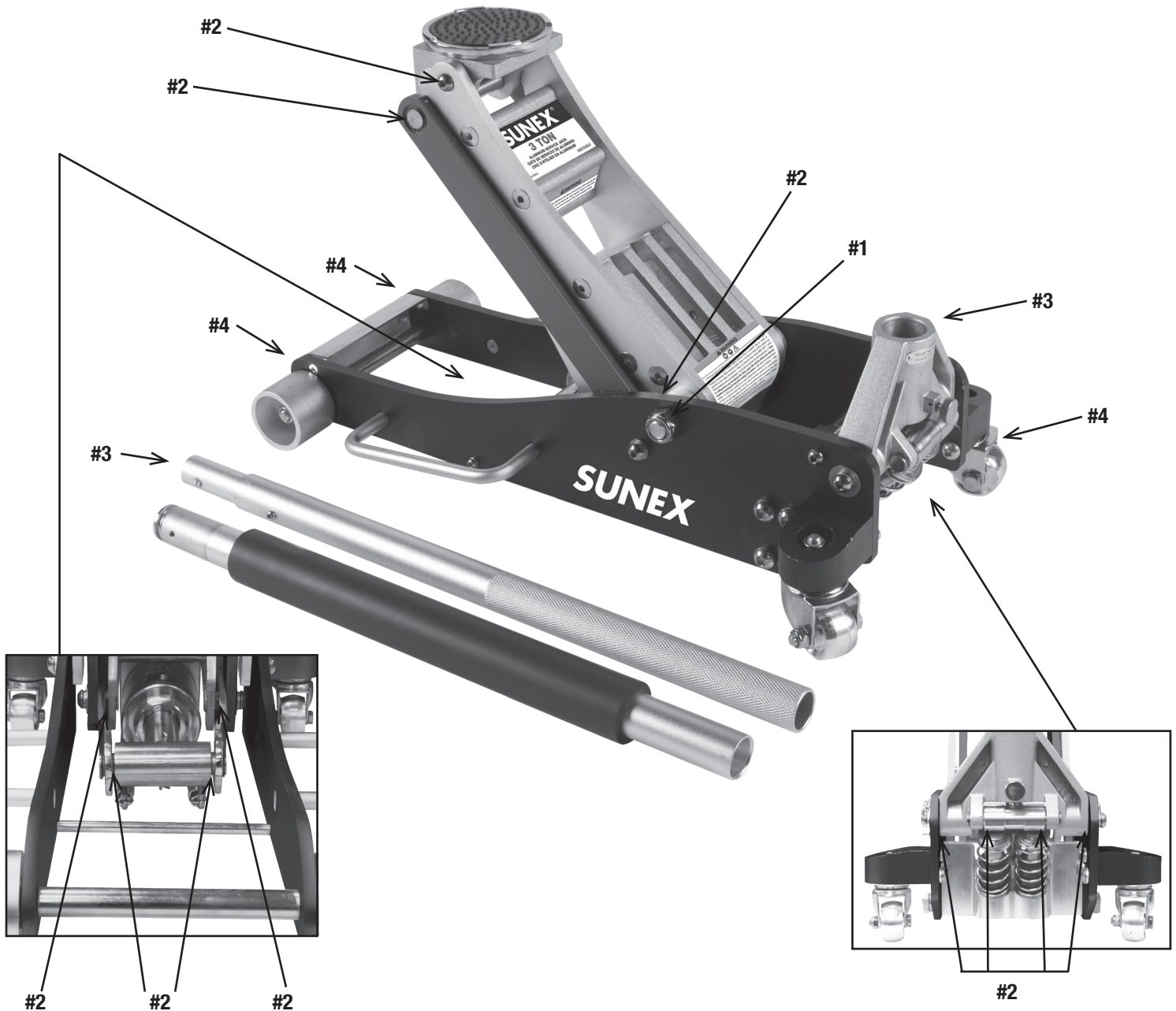

PARTS LIST AND DRAWING

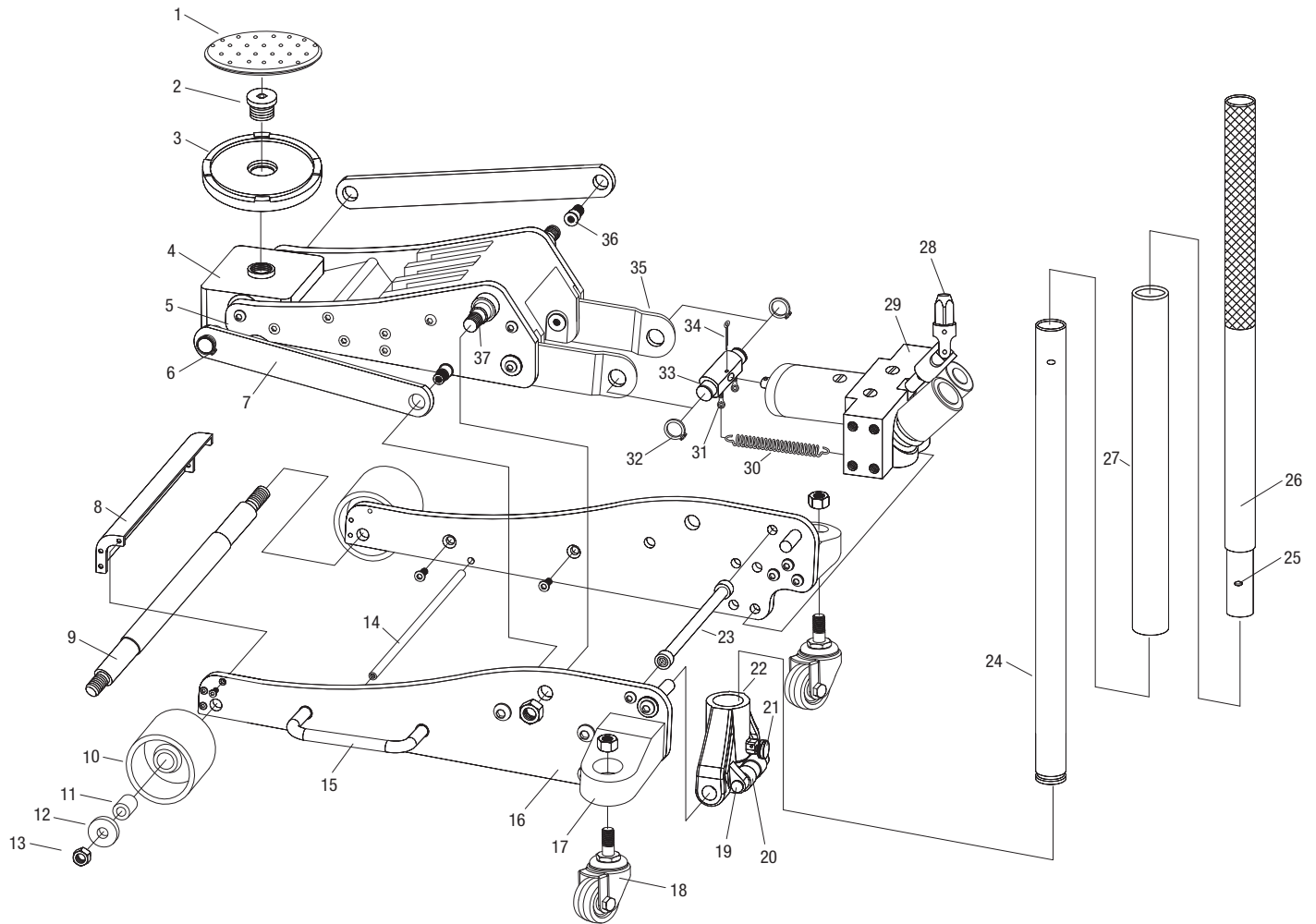

REF #	PART#	DESCRIPTION	QTY
1	RS6603ASJ38	Rubber Saddle Pad	1
2		Saddle Bolt	1
3	RS6603ASJ36	Saddle	1
4		Saddle Seat	1
5		Lift Arm Side Plate	1
6		Retaining Ring (18)	2
7		Link Rod	2
8		Baffle	1
9		Front Wheel Axle	1
10	RS6603ASJ17	Front Wheel Assembly (incl. #11, 12, 13)	2
11		Bushing (incl. with #10)	2
12		Washer (incl. with #10)	2
13	RS6603ASJ03	Nut (M12) (incl. with #10)	4
14		Rod	1
15	RS6603ASJ15	Carry Handle (incl. hardware)	2
16		Frame	2
17		Rear Caster Bracket	2
18	RS6603ASJ01	Rear Caster	2
19		Roller Pin	1
20		Roller	1

REF #	PART#	DESCRIPTION	QTY
21	RS6603ASJ54	Handle Yoke Set Screw	1
22	RS6603ASJ55	Handle Yoke Assembly	1
23		Rod	1
24	RS6603ASJ60	Lower Handle	1
25		Lock	1
26	RS6603ASJ62	Upper Handle	1
27	RS6603ASJ61	Handle Bumper	1
28		U-Joint	1
29	RS6603ASJ50	Power Unit Assembly	1
30		Spring	2
31		Bolt	2
32		Retaining Ring (22)	2
33		Linkage Rod	1
34		Cotter Pin	1
35		Linkage	2
36		Linkage Rod Bolt	2
37		Lift Arm Axle	1
	RS6603ASJPLK	Product Label Kit (not shown)	1

Only items identified by part number are available individually.

PARTS LIST
AND DRAWING

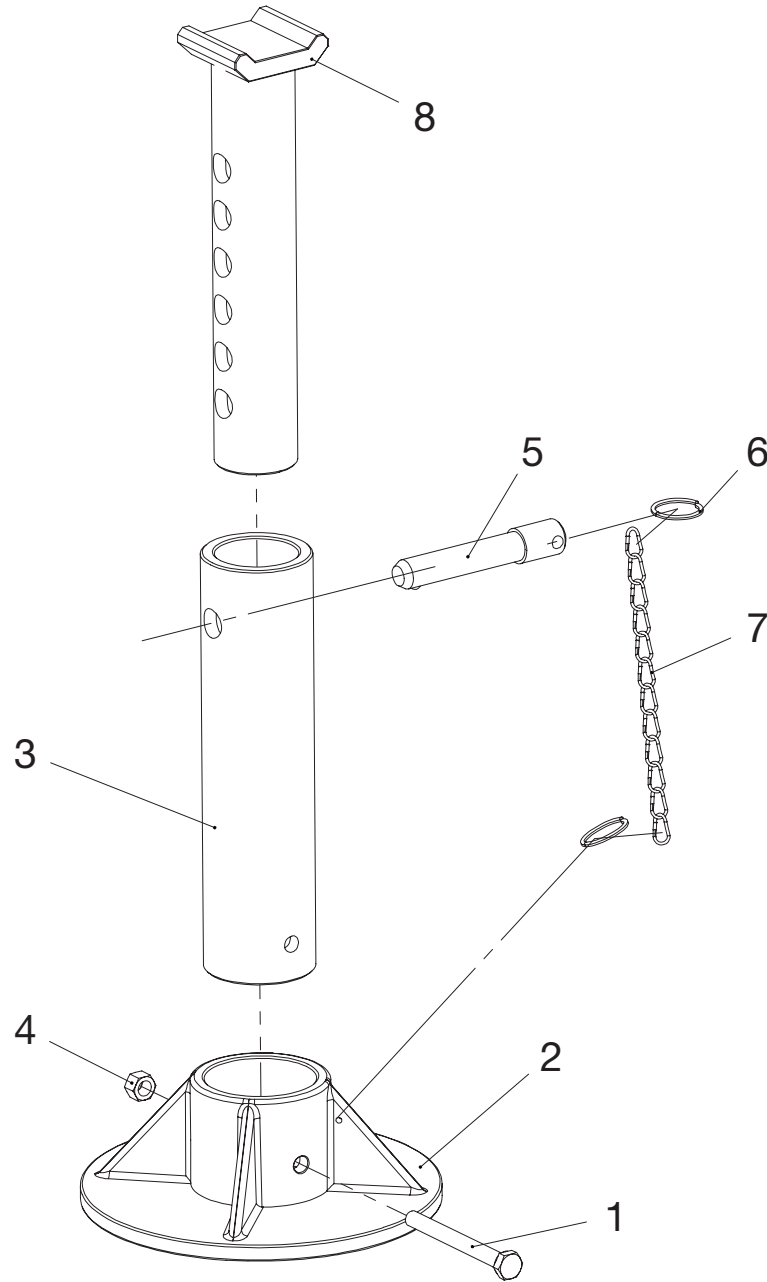

REF #	PART#	DESCRIPTION	QTY
1	RS100301	Bolt (M8x80)	1
2		Base	1
3		Support Column	1
4	RS100304	Nut (M8)	1
5	RS3TPRCS	Lock Pin (incl. #6, 7)	1
6		Key Ring (incl. with #5)	2
7		Chain (incl. with #5)	1
8		Saddle Column	1
	RS1003AJLK	Label Kit (not shown)	1

Only items identified by part number are available individually.