

! WARNING

- Do not exceed rated capacity of 700 lbs.
- Do not exceed maximum width of 61"
- Never crawl under the suspended load for any reason.
- Be sure engine is supported securely before proceeding.
- To avoid personal injury or property damage, read, understand and follow all instructions before using.

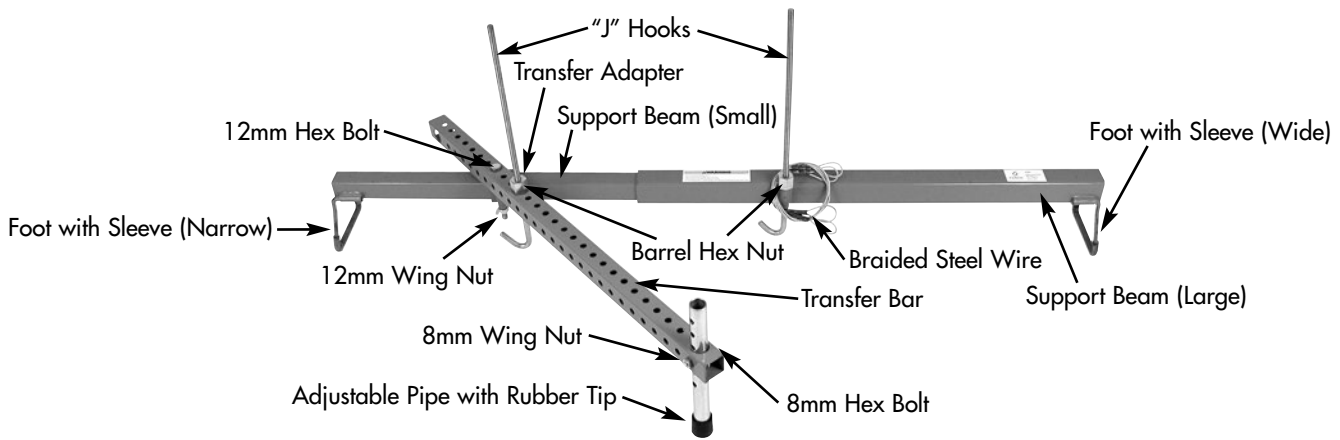

ASSEMBLY INSTRUCTIONS...

Remove all contents from box and be sure all components above are included. First, insert feet with sleeves (#13, 14) into short tubes welded at the end of both support beams (#1,2).

NOTE: The widest foot (#13) goes on the largest support beam (#1).

Slide transfer adapter (#11) over the end of small support beam (#2) as shown in parts drawing (p. 3) with short tube toward you and in the up & down position. This transfer adapter will be used for mounting the transfer bar (#10) when needed or J-hook (#3) when the transfer bar is not used.

NOTE: The 5207 Engine Transverse Bar may be used with or without transfer bar, depending on the load being supported.

If mounting the transfer bar (#10) to assist with an unbalanced load, insert the adjustable pipe (#6) with the rubber tip up through the large hole at either end of the transfer bar (#10) and secure in place with hex bolt (#9) and wing nut (#8). Do not fully tighten wing nut as height adjustment may be necessary once the 5207 Engine Transverse Bar is placed over the engine compartment of the vehicle.

Then, after determining the length of transfer bar needed to ensure correct placement of the adjustable pipe (#6) and to properly assist in supporting the load, insert hex bolt (#5) down through the transfer bar (#10) and the short tube of the transfer adapter (#11) to hold transfer bar in place on the small support beam. Secure bolt with wing nut (#4). Again, do not fully tighten wing nut (#4), as some length adjustment may be required once the Engine Support Bar is placed in support position over engine compartment of the vehicle.

Now, it is time to install the two J-hooks (#3) provided. This must be done **BEFORE** placing the 5207 Engine Support Bar over the engine compartment, because ample space may not be available once the support bar is in place. Insert one J-hook up through the bottom of short tube welded on the center portion of the large support beam (#1) and secure with barrel hex nut (#7). Run hex nut (#7) all the way down to end of threads toward the hook portion of the J-hook to hold it out of the way until needed. Then, locate the best position for the second J-hook and install in the same manner. The second J-hook may be installed in either the transfer bar (#10) as shown in the parts drawing (if the transfer bar is used), or through the short tube welded on the adjustable transfer adapter (#11) (if the transfer bar is not used).

Now, the 5207 Engine Support Bar is ready to be placed over the engine compartment of the vehicle.

USING THE 5207 ENGINE TRANSVERSE BAR...

First, determine the location of the two engine support bolts to which the 5207 Engine Support Bar will be attached. Then, place the Engine Support Bar directly over these two engine support bolts, making sure that the feet with protective sleeves (#13,14) are sitting in the inner fender lips of the engine compartment and fully extended until the feet are touching the inside of the fenders.

CAUTION: If the inside fender lips are more than 61" apart, the 5207 Engine Transverse Bar must not be used. Do not extend past the designated marking (61") as over-extending this unit may compromise the 700 lb. Capacity. This could cause the Engine Support Bar to collapse, resulting in bodily injury or property damage.

Next, make sure the transfer bar is in correct position (if being used). The rubber tip of the adjustable pipe (#6) should be on a flat, reinforced surface capable of supporting the weight of the engine. Tighten both wing nuts (#4, 8) to secure adjustable pipe (#6) and transfer bar (#10).

Now, the J-hooks (#3) may be lowered to the appropriate position. Be sure J-hooks are directly over the engine support bolts or brackets so the engine does not swing when vehicle is disassembled. Attach the looped ends of the two 1/8" braided steel cables (#12) to the engine support bolts on the engine and loop middle of braided cables over J-hooks. If the engine being supported is equipped with engine lift brackets, hook the J-hooks directly into engine lift brackets for extra protection.

NOTE: Use only fasteners rated Grade 5 or higher as engine support bolts.

Tighten the barrel hex nuts (#7) on both J-hooks until cables are snug or hex nuts are tight against support bar. Double check that engine is properly supported before disassembly of vehicle.

**Engine Transverse Bar
with Arm Support**

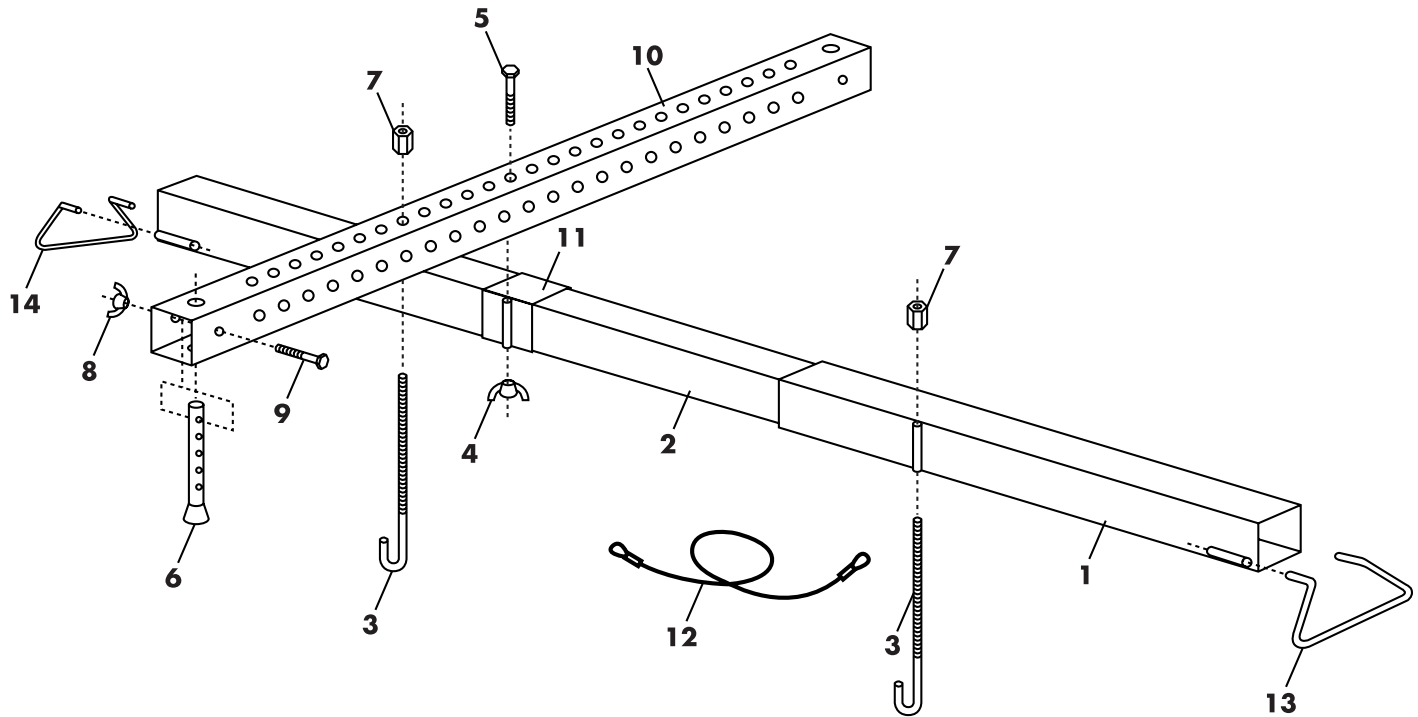

Item No.	Part No.	Description	Quantity	Item No.	Part No.	Description	Quantity
1		Support Beam (Large)	1	8	*	Wing Nut M8	1
2		Support Beam (Small)	1	9	*	Hex Bolt M8 x 65	1
3	*	"J" Hooks	2	10		Transfer Bar	1
4	*	Wing Nut M12	1	11		Transfer Adapter	1
5	*	Hex Bolt M12 x 120	1	12	RS520712	Braided Steel Wire	2
6	RS520706	Adjustable Pipe with Rubber Tip	1	13	**	Foot with Sleeve (Wide)	1
7	*	Barrel Hex Nut	2	14	**	Foot with Sleeve (Narrow)	1

* RS5207BK (includes item # 3, 4, 5, 7, 8, 9)

** RS5207FT (includes item # 13, 14)

Only items with part numbers are available as replacement parts.