



For ALL Your Air Suspension Needs!!!

2003-2006

***Lincoln Navigator
Ford Expedition***

60F-30-F

Front Conversion kit





For ALL Your Air Suspension Needs!!!

WARNING:

BEFORE YOU BEGIN THE REMOVAL OR INSTALLATION, READ ALL INSTRUCTIONS THOROUGHLY! THE WARRANTY WILL BE VOID IF INSTRUCTIONS ARE NOT FOLLOWED EXACTLY. DO NOT WORK UNDER CAR UNDER A VEHICLE SUPPORTED BY A JACK. ALWAYS SUPPORT THE VEHICLE ON SAFETY STANDS.

WARNING: THE ELECTRICAL POWER TO THE AIR SUSPENSION SYSTEM MUST BE SHUT OFF PRIOR TO HOISTING, JACKING OR TOWING AN AIR SUSPENSION VEHICLE. THIS CAN BE ACCOMPLISHED BY TURNING "OFF" THE AIR SUSPENSION SWITCH LOCATED IN THE LH REAR QUARTER TRIM PANEL. FAILURE TO DO SO MAY RESULT IN UNEXPECTED INFLATION OR DEFLATION OF THE AIR SPRINGS, WHICH CAN RESULT IN SHIFTING OF THE VEHICLE DURING THESE OPERATIONS. DO NOT REMOVE ANY COMPONENTS WITHOUT EXHAUSTING THE AIR OR PROVIDING SUPPORT FOR THE AIR SPRING TO PREVENT VEHICLE DAMAGE OR PERSONAL INJURY.

- 1 Turn the air suspension switch to the "OFF" position.
- 2 Raise and support the vehicle.
- 3 Remove the wheel and tire assemblies.
- 4 Purge the air suspension system.
- 5 Disconnect the electrical connector and remove the air line assembly. (See diagram on page 2.)
- 6 Remove the upper mounting nuts. (See diagram on page 2.)
- 7 Remove the nut, bolt and air strut. (See diagram on page 2.)
- 8 **INSTALLATION:** To install, reverse the removal procedure.

5

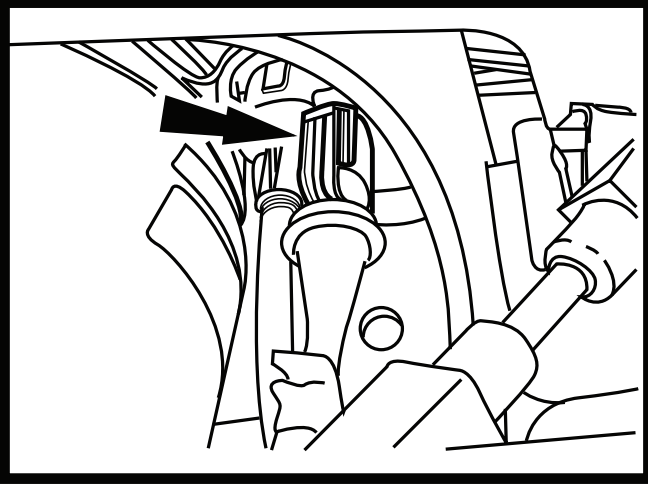

6

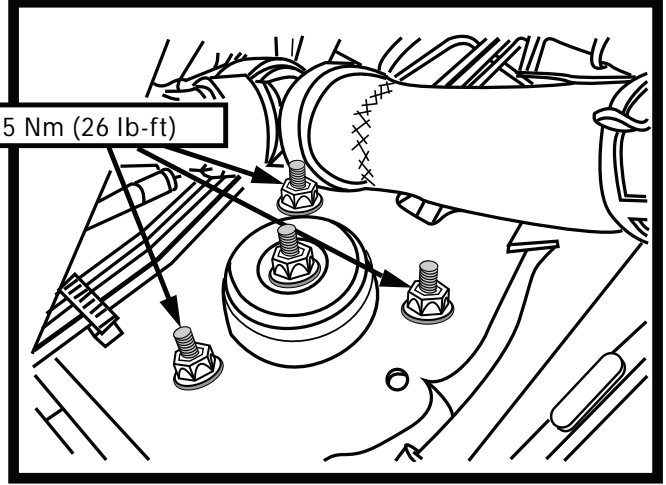

7

