



For ALL Your Air Suspension Needs!!!

1993-1998

Lincoln Mark 8



50F-30-R

Rear Conversion kit



For ALL Your Air Suspension Needs!!!

WARNING:

BEFORE YOU BEGIN THE REMOVAL OR INSTALLATION, READ ALL INSTRUCTIONS THOROUGHLY! THE WARRANTY WILL BE VOID IF INSTRUCTIONS ARE NOT FOLLOWED EXACTLY. DO NOT WORK UNDER CAR UNDER A VEHICLE SUPPORTED BY A JACK. ALWAYS SUPPORT THE VEHICLE ON SAFETY STANDS.

- 1 Turn air suspension switch off.
- 2 Raise vehicle and remove the wheel.
- 3 Release the air pressure by removing the air spring solenoid valve.
- 4 Release the plastic clips, push up on the air bag; then push down on the metal tab.
- 5 Twist air spring counter-clockwise, pull the air spring out.
- 6 You will need to unbolt your shock and stabilizer rod, so the rear axle will lower itself to install the spring kit.
- 7 With the top plate provided, set the spring in the bucket.
- 8 Be sure to turn both of the springs in the same direction.
- 9 Use reverse procedure to complete the job.
- 10 Be sure to securely plug both airlines after removing solenoids (2-wheel kits only.)
- 11 See attached instructions to disarm suspension warning light.
- 12 In the Trunk Turn main air ride switch on.

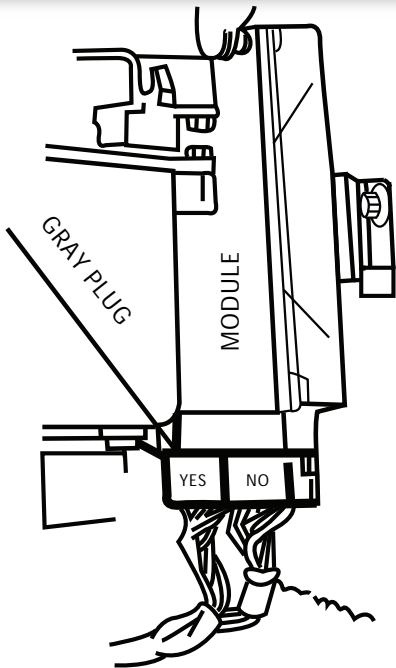

MARK 8 DISARM SUSPENSION LIGHT

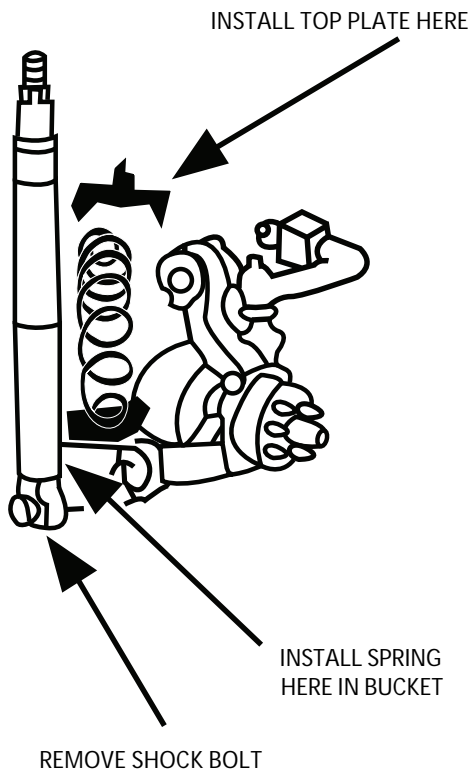
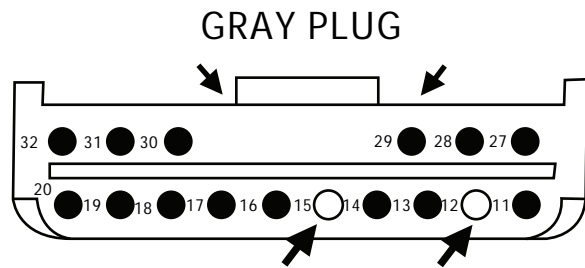



For ALL Your Air Suspension Needs!!!

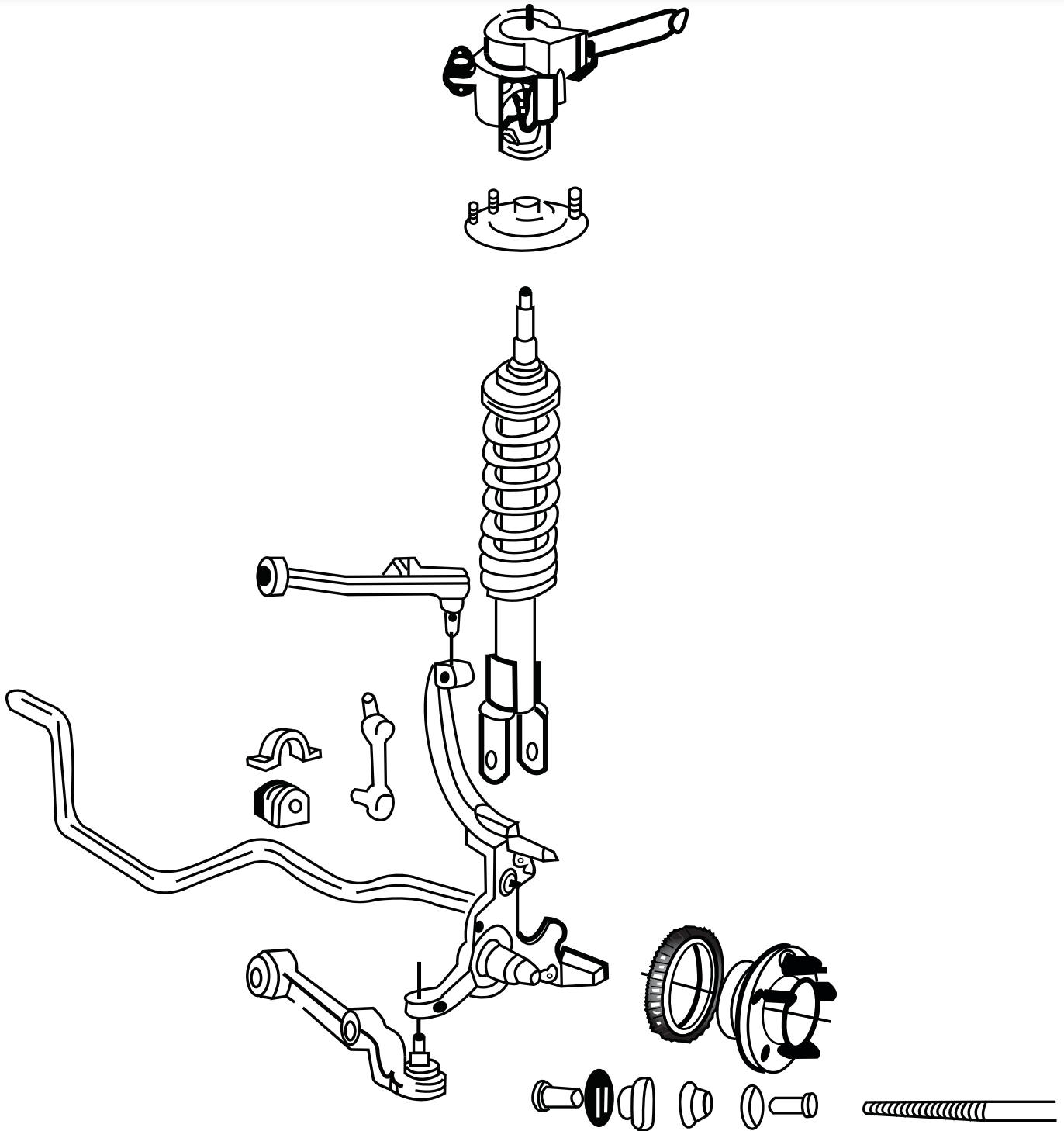

50F-30-R

3.

Learn more about suspension parts on our website.