



For ALL Your Air Suspension Needs!!!

1993-1998

Lincoln Mark 8



50F-30-F

Front Conversion kit



For ALL Your Air Suspension Needs!!!

WARNING:

BEFORE YOU BEGIN THE REMOVAL OR INSTALLATION, READ ALL INSTRUCTIONS THOROUGHLY! THE WARRANTY WILL BE VOID IF INSTRUCTIONS ARE NOT FOLLOWED EXACTLY. DO NOT WORK UNDER CAR UNDER A VEHICLE SUPPORTED BY A JACK. ALWAYS SUPPORT THE VEHICLE ON SAFETY STANDS.

- 1 Turn air suspension switch off.
- 2 Raise vehicle and remove the wheel.
- 3 Remove the Upper Control Arm by removing the pinch bolt and nut. Position the air suspension height sensor out of the way.
- 4 Tap the wishbone control arm upward.
- 5 Twist air spring counter-clockwise, pull the air spring out.
- 6 Unbolt the brake line bracket that is mounted to the frame.
- 7 Go to the engine compartment and remove the three shock tower nuts 13mm.
- 8 Pull air strut out and install the kit in reverse procedure.
- 9 Be sure to securely plug both airlines after removing solenoids.
(2-wheel kits only)
- 10 See attached instructions to disarm suspension warning light.
If this DOES NOT turn out the suspension warning light, you can cut the ground wire to the suspension compressor.
- 11 In the Trunk Turn main air ride switch on.



For ALL Your Air Suspension Needs!!!

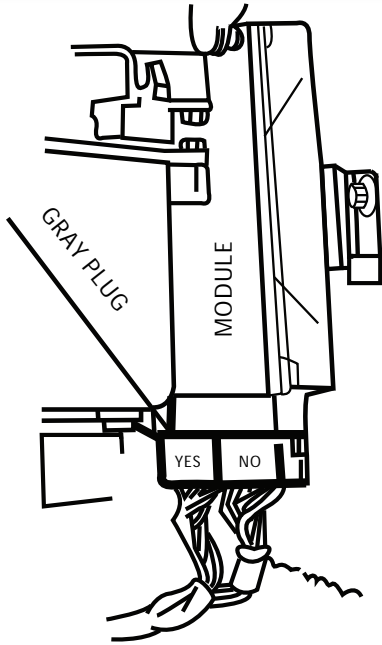

MARK 8 DISARM SUSPENSION LIGHT

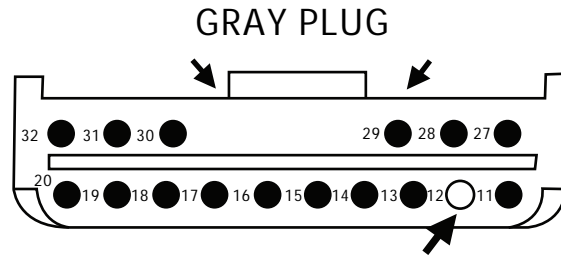



For ALL Your Air Suspension Needs!!!

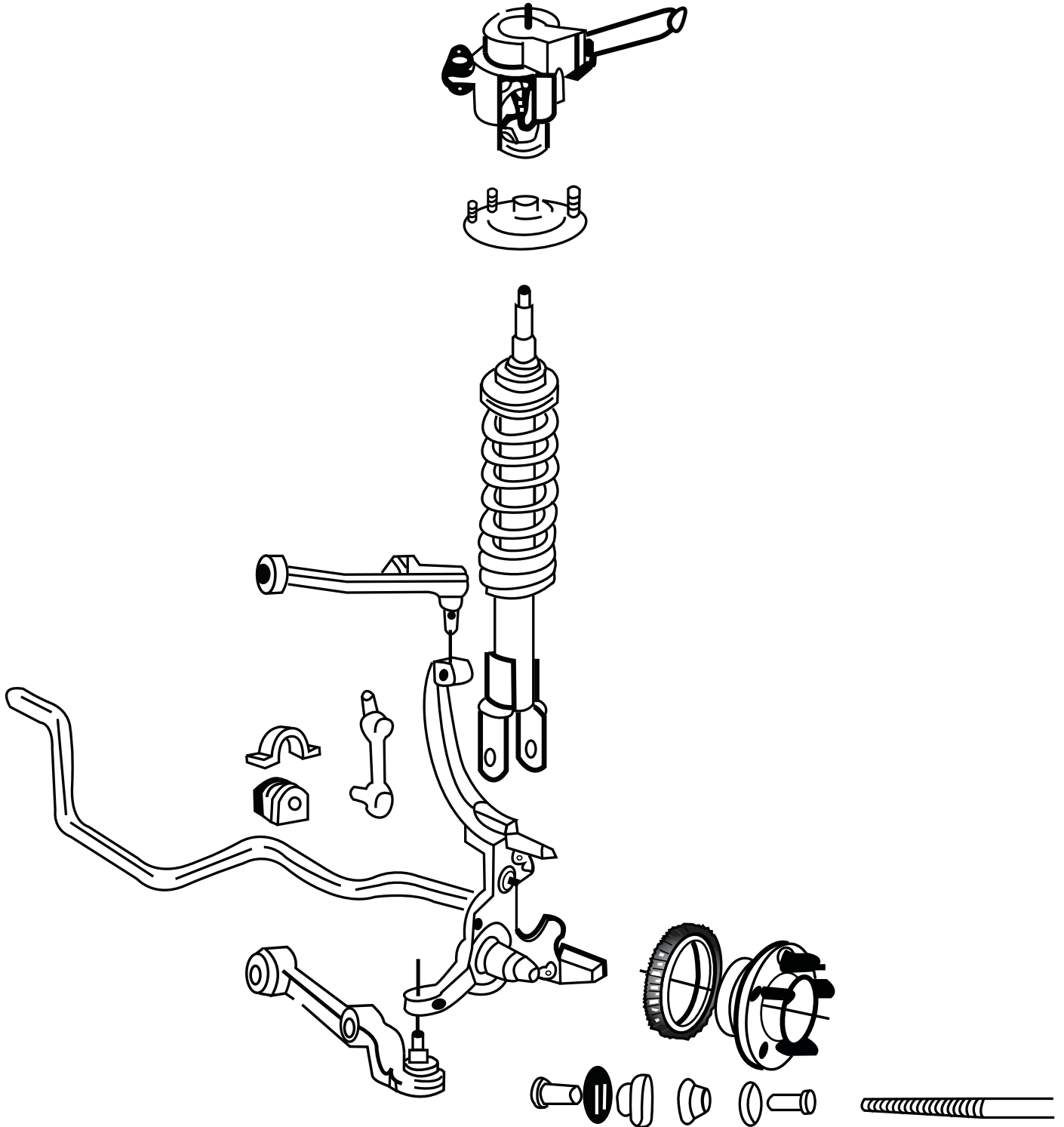

50F-30-F

3.

Learn more about suspension parts on our website.