



***For ALL Your Air Suspension Needs!!!***

**1993-1998**

***Lincoln Mark 8***



**50F-30-4**

***4-Wheel Conversion kit***



**For ALL Your Air Suspension Needs!!!**

**WARNING:**

**BEFORE YOU BEGIN THE REMOVAL OR INSTALLATION, READ ALL INSTRUCTIONS THOROUGHLY! THE WARRANTY WILL BE VOID IF INSTRUCTIONS ARE NOT FOLLOWED EXACTLY. DO NOT WORK UNDER CAR UNDER A VEHICLE SUPPORTED BY A JACK. ALWAYS SUPPORT THE VEHICLE ON SAFETY STANDS.**

**Front Conversion**

- 1 Turn air suspension switch off.
- 2 Raise vehicle and remove the wheel.
- 3 Remove the Upper Control Arm by removing the pinch bolt and nut. Position the air suspension height sensor out of the way.
- 4 Tap the wishbone control arm upward.
- 5 Twist air spring counter-clockwise, pull the air spring out.
- 6 Unbolt the brake line bracket that is mounted to the frame.
- 7 Go to the engine compartment and remove the three shock tower nuts 13mm.
- 8 Pull air strut out and install the kit in reverse procedure.
- 9 Be sure to securly plug both airlines after removing solenoids.  
( 2-wheel kits only)
- 10 See attached instructions to disarm suspension warning light.  
If this DOES NOT turn out the suspension warning light, you can cut the ground wire to the suspension compressor.
- 11 In the Trunk Turn main air ride switch on.



For ALL Your Air Suspension Needs!!!

Front Conversion

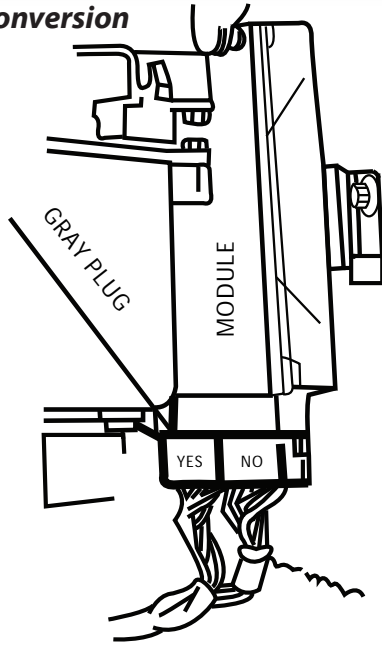

MARK 8 DISARM SUSPENSION LIGHT

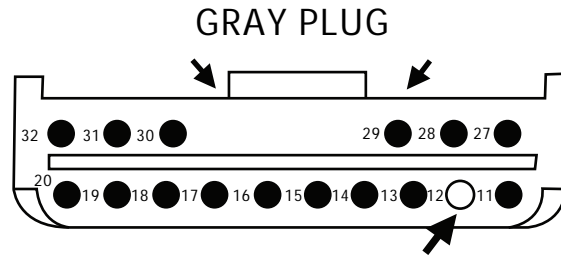



For ALL Your Air Suspension Needs!!!

Front Conversion

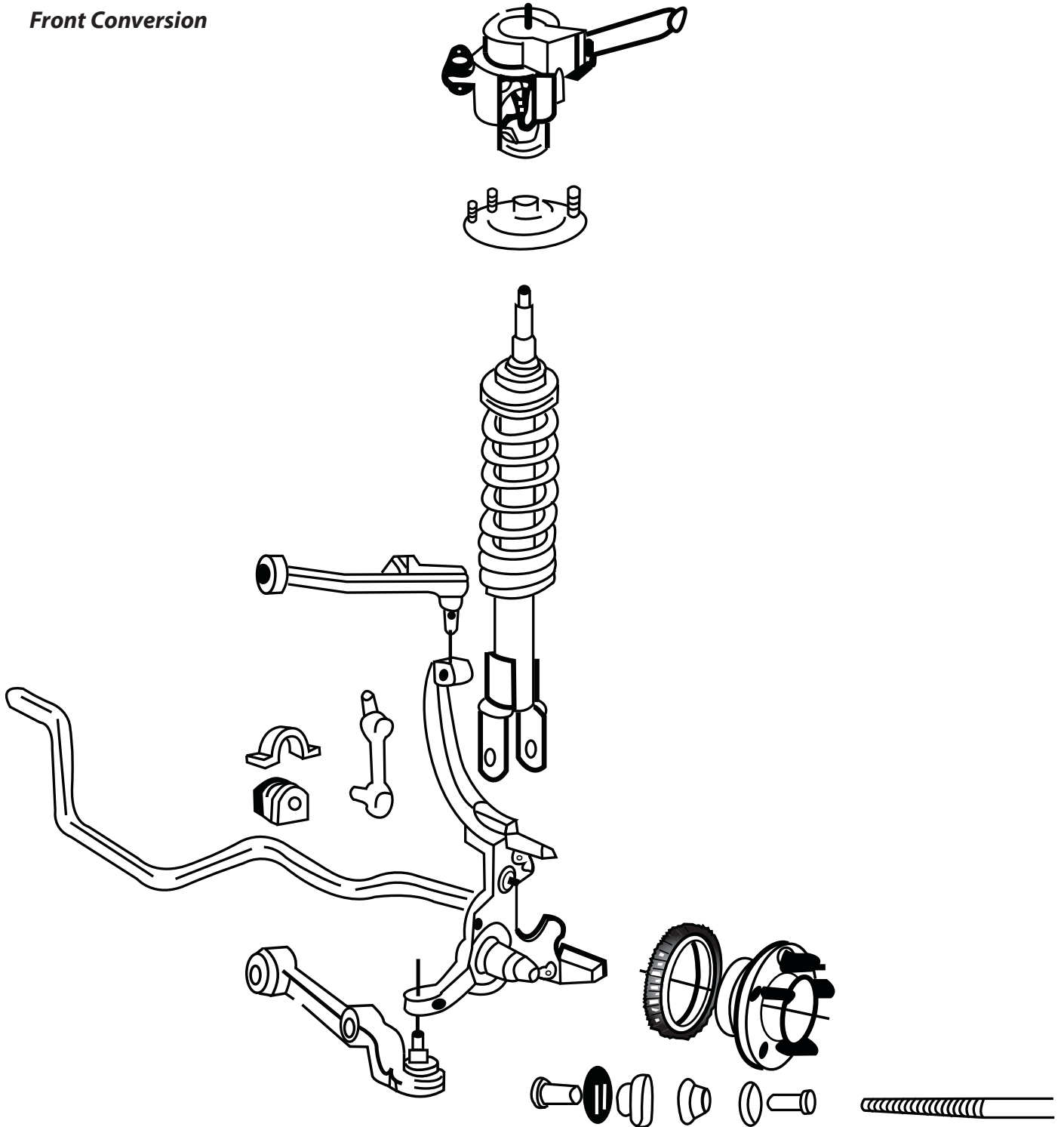



**For ALL Your Air Suspension Needs!!!**

### **Rear Conversion**

- 1 Turn air suspension switch off.
- 2 Raise vehicle and remove the wheel.
- 3 Release the air pressure by removing the air spring solenoid valve.
- 4 Release the plastic clips, push up on the air bag; then push down on the metal tab.
- 5 Twist air spring counter-clockwise, pull the air spring out.
- 6 You will need to unbolt lower shock and stabilizer rod, so the rear axle will lower itself to install the spring kit.
- 7 With the top plate provided, set the spring in the bucket.
- 8 Be sure to turn both of the springs in the same direction.
- 9 Use reverse procedure to complete the job.
- 10 Be sure to securely plug both airlines after removing solenoids (2-wheel kits only.)
- 11 See attached instructions to disarm suspension warning light.
- 12 In the Trunk Turn main air ride switch on.



For ALL Your Air Suspension Needs!!!

Rear Conversion

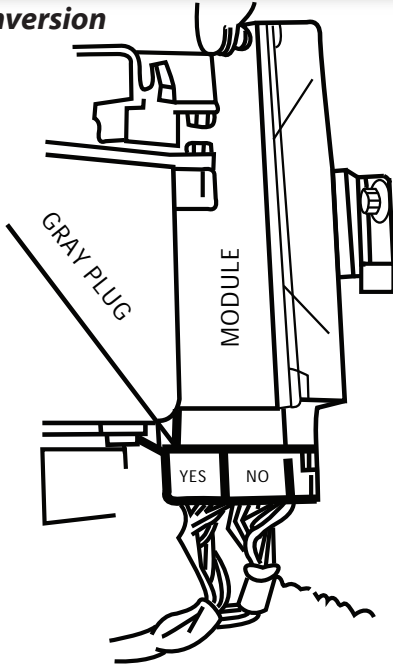

MARK 8 DISARM SUSPENSION LIGHT

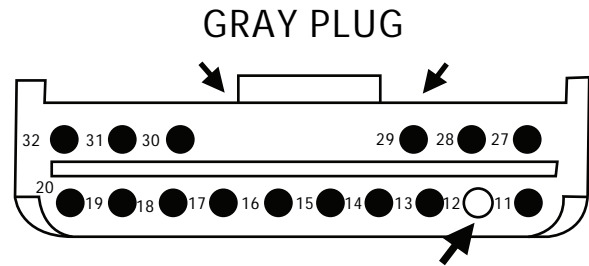

INSTALL TOP PLATE HERE

