



***For ALL Your Air Suspension Needs!!!***

***Ford-*** *Crown Victoria 1990-1997*

***Lincoln-***  
*Continental 1997-2002*  
*Town Car 1990-1997*

***Mercury-***  
*Grand Marquis 1990-1997*



***40F-25-1***  
***Dryer***



**For ALL Your Air Suspension Needs!!!**

**WARNING:**

**BEFORE YOU BEGIN THE REMOVAL OR INSTALLATION, READ ALL INSTRUCTIONS THOROUGHLY! THE WARRANTY WILL BE VOID IF INSTRUCTIONS ARE NOT FOLLOWED EXACTLY. DO NOT WORK UNDER CAR UNDER A VEHICLE SUPPORTED BY A JACK. ALWAYS SUPPORT THE VEHICLE ON SAFETY STANDS.**

**REMOVAL**

**WARNING: TURN AIR SUSPENSION SWITCH OFF TO PREVENT VEHICLE DAMAGE OR PERSONAL INJURY.**

1. **Disconnect battery ground cable.**
2. **See page 2 for airline Disconnect/Connect instructions.**
3. **Remove air compressor and compressor air drier assembly.**
4. **Remove compressor air drier-to-compressor retaining screw.**
5. **Twist compressor air drier clockwise to disengage from air compressor.**

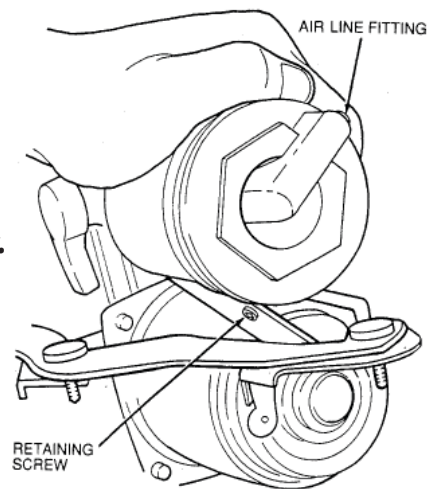
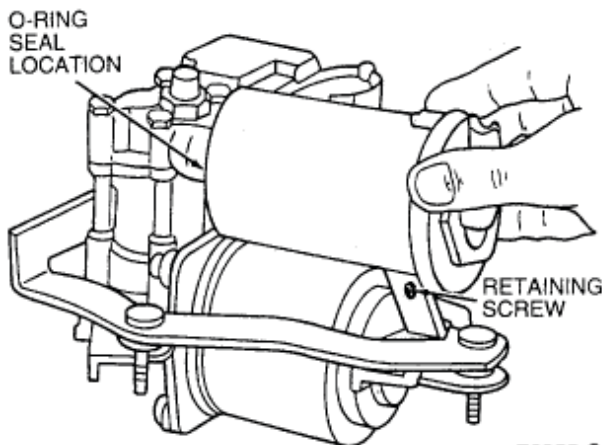

6. **Remove compressor air drier and O-ring seal. Discard O-ring seal.**

**INSTALLATION**

1. **Install new O-ring on compressor air drier to make sure it is properly seated on compressor air drier end.**
2. **Install compressor air drier into air compressor and twist counterclockwise.**
3. **Install compressor air drier-to-compressor retaining screw. Tighten to 1.6-2.8 Nm (15-24 inch lbs.).**
4. **Install air compressor and compressor air drier assembly,.**
5. **Connect battery ground cable.**

**NOTE: Disconnect battery ground cable before raising vehicle.**

### Releasing Air Line

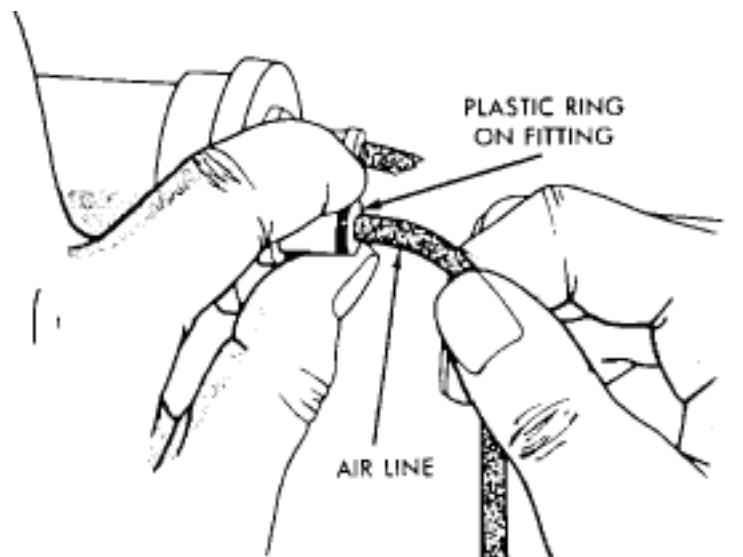

1. To release an air line from fitting, pull back on plastic ring, then remove line from fitting.

### Attaching Air Line

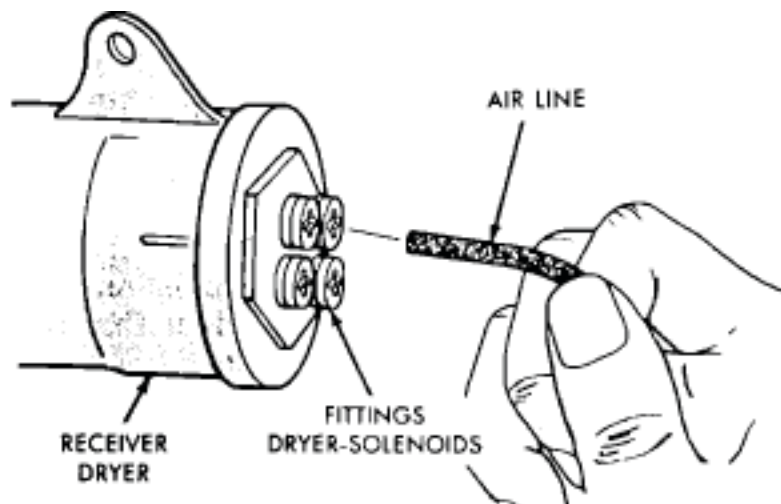

2. Air line fittings have a push-in feature. A brass type Colette locks the air line in place. One rubber O-ring seals the air line to prevent leakage. To attach air line, push into fitting.