



***For ALL Your Air Suspension Needs!!!***

***Chrysler-*** Imperial 1990-1993, New Yorker 1990-1996

***Lincoln-*** Mark 7 1984-1992, Continental 1984-1987



**36F-20-4**

**Compressor**



**For ALL Your Air Suspension Needs!!!**

**WARNING:**

**BEFORE YOU BEGIN THE REMOVAL OR INSTALLATION, READ ALL INSTRUCTIONS THOROUGHLY! THE WARRANTY WILL BE VOID IF INSTRUCTIONS ARE NOT FOLLOWED EXACTLY. DO NOT WORK UNDER CAR UNDER A VEHICLE SUPPORTED BY A JACK. ALWAYS SUPPORT THE VEHICLE ON SAFETY STANDS.**

1. **Disconnect battery ground cable.**
2. **Raise and support vehicle.**

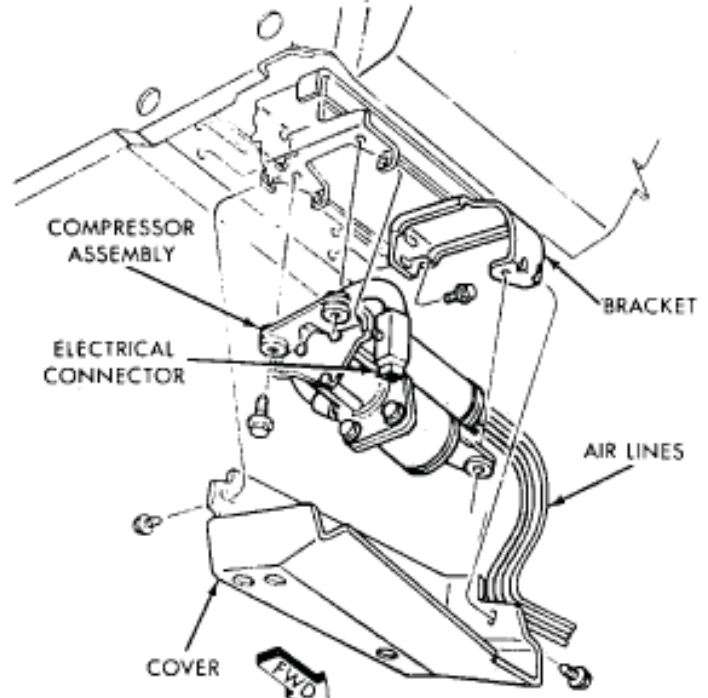

3. **Remove cover from compressor assembly.**
4. **Disconnect air lines and electrical connectors from air compressor.**  
**See: Air Line\Service and Repair Page 2.**
5. **Remove compressor assembly mounting screws, then the compressor assembly.**
6. **Remove mounting bracket screws, then slide mounting bracket away from compressor.**
7. **Reverse procedure to install, noting the following:**
  - a. **Torque compressor mounting bracket screws to 70 lb-in .**
  - b. **Torque compressor assembly mounting screws to 70 lb-in .**
  - c. **Torque compressor cover mounting screws to 40 lb-in .**
  - d. **Check system operation.**

**NOTE:** Disconnect battery ground cable before raising vehicle.

### Releasing Air Line

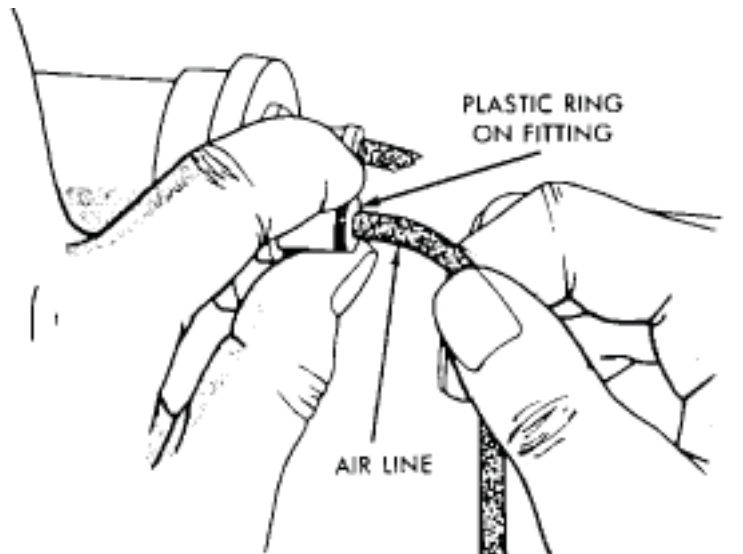

1. To release an air line from fitting, pull back on plastic ring, then remove line from fitting.

### Attaching Air Line

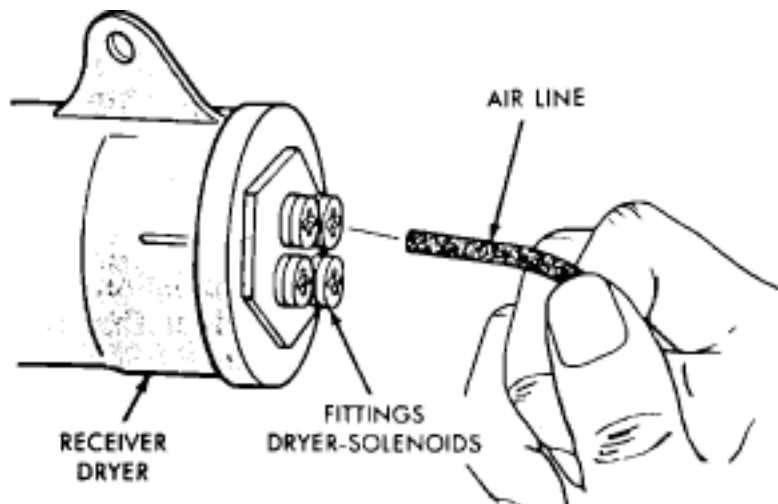

2. Air line fittings have a push-in feature. A brass type Colette locks the air line in place. One rubber O-ring seals the air line to prevent leakage. To attach air line, push into fitting.