



For ALL Your Air Suspension Needs!!!

Mercury Mountaineer '97-'01

Explorer Sport Track '01-'05

Ford Explorer '95-'03



135F-30-F

Front Conversion Kit



For ALL Your Air Suspension Needs!!!

WARNING:

BEFORE YOU BEGIN THE REMOVAL OR INSTALLATION, READ ALL INSTRUCTIONS THOROUGHLY! THE WARRANTY WILL BE VOID IF INSTRUCTIONS ARE NOT FOLLOWED EXACTLY. DO NOT WORK UNDER CAR UNDER A VEHICLE SUPPORTED BY A JACK. ALWAYS SUPPORT THE VEHICLE ON SAFETY STANDS.

Removal

WARNING: The electrical power to the air suspension system must be shut off prior to hoisting, jacking or towing of an air suspension vehicle. This can be accomplished by turning off the air suspension switch located in the rear jack storage area. Failure to do so may result in unexpected inflation or deflation of the air springs which may result in shifting of the vehicle during these operations.

WARNING: The low pressure gas shock absorbers are charged with nitrogen gas 930 kPa (135 psi). Do not attempt to open, puncture, or apply heat to the shock absorbers.

1. **Connect New Generation STAR (NGS) Tester to the Data Link Connector (DLC) .**
2. **Select the RIDE CONTROL OUTPUT screen and turn on the solenoids to vent the entire system of air and to lower the vehicle to its lowest attainable height:**

- * **REAR FILL (rear fill solenoid).**
- * **GATEVALVE(gate solenoid[s]).**
- * **VENT (vent solenoid).**

3. **Raise and support the vehicle.**
4. **Remove the spare tire.**

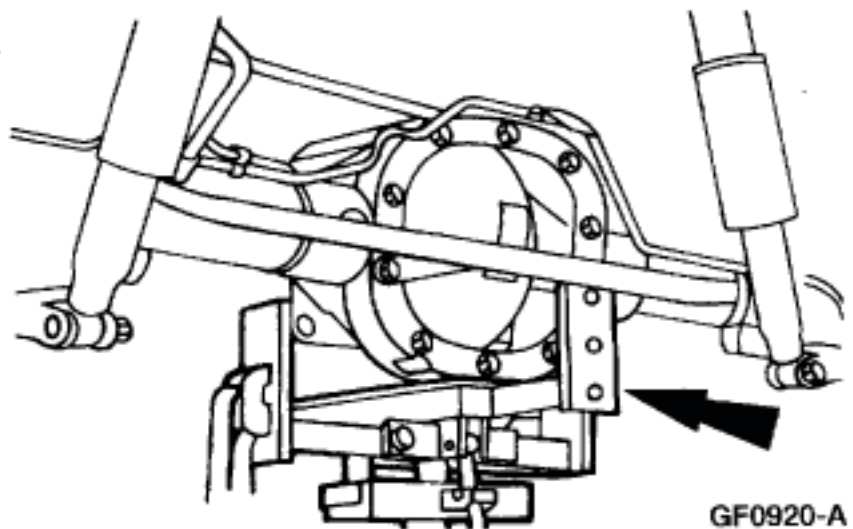



For ALL Your Air Suspension Needs!!!

WARNING:

BEFORE YOU BEGIN THE REMOVAL OR INSTALLATION, READ ALL INSTRUCTIONS THOROUGHLY! THE WARRANTY WILL BE VOID IF INSTRUCTIONS ARE NOT FOLLOWED EXACTLY. DO NOT WORK UNDER CAR UNDER A VEHICLE SUPPORTED BY A JACK. ALWAYS SUPPORT THE VEHICLE ON SAFETY STANDS.

5. Use Hi-Lift Transmission Jack to support the rear axle.

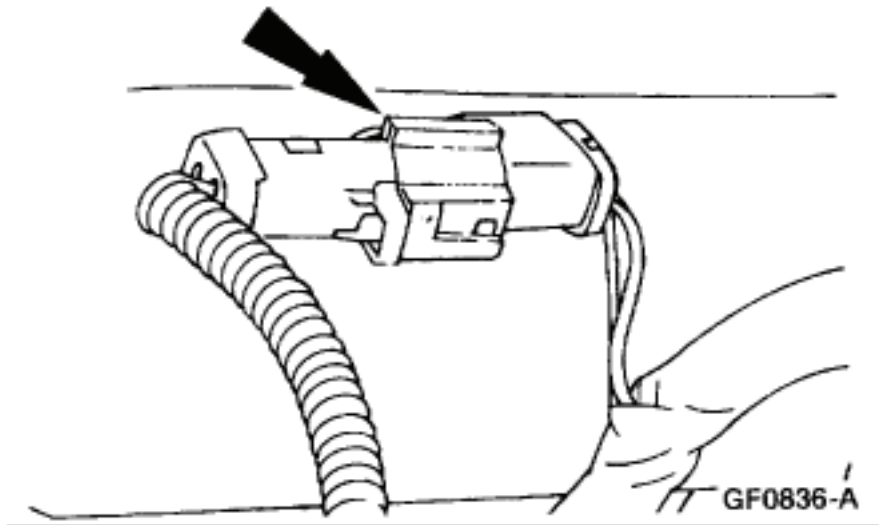

6. Remove the rear shock absorber electrical connector from the rear crossmember and disconnect the electrical connector.

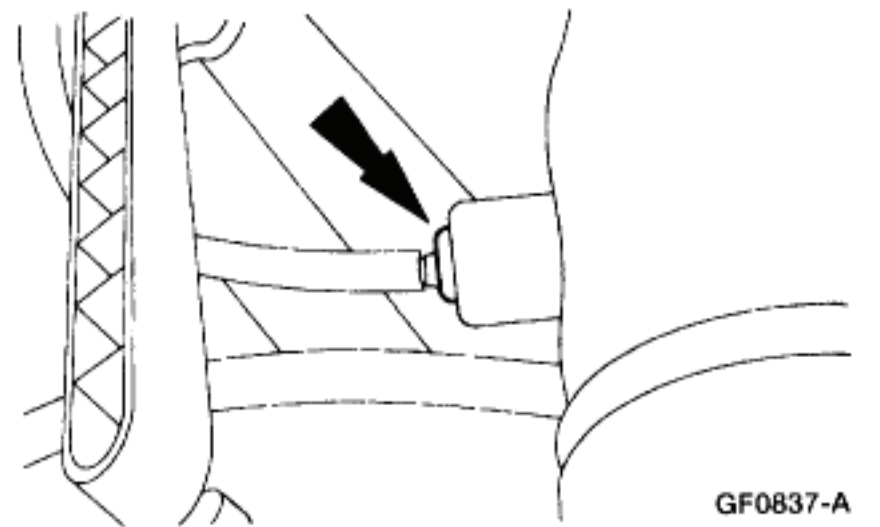



For ALL Your Air Suspension Needs!!!

WARNING:

BEFORE YOU BEGIN THE REMOVAL OR INSTALLATION, READ ALL INSTRUCTIONS THOROUGHLY! THE WARRANTY WILL BE VOID IF INSTRUCTIONS ARE NOT FOLLOWED EXACTLY. DO NOT WORK UNDER CAR UNDER A VEHICLE SUPPORTED BY A JACK. ALWAYS SUPPORT THE VEHICLE ON SAFETY STANDS.

7. *Disconnect the air line from the shock absorber.*

* *Compress the quick connect locking ring and pull out the air line.*

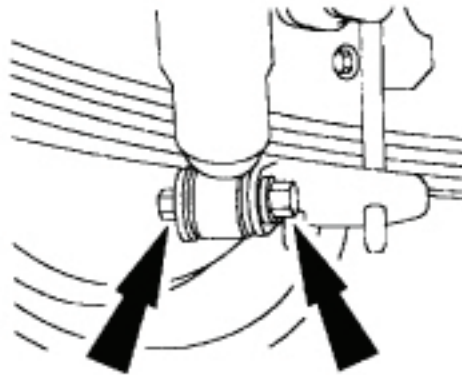

8. *Remove the shock absorber lower retaining nut and bolt and swing the shock absorber out of the lower mounting bracket.*

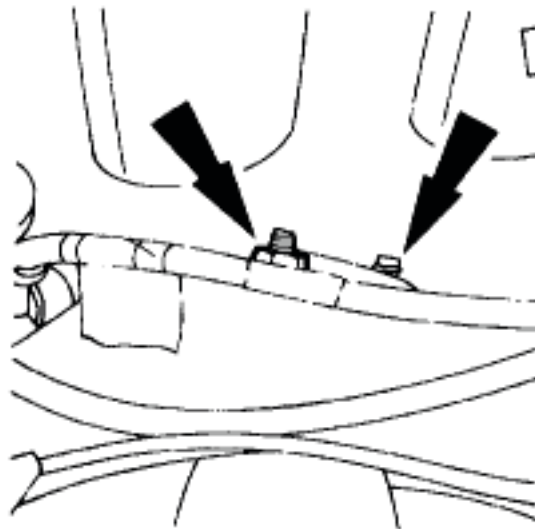

9. *Remove the attaching nuts on top of the rear crossmember and remove the shock absorber.*



For ALL Your Air Suspension Needs!!!

WARNING:

BEFORE YOU BEGIN THE REMOVAL OR INSTALLATION, READ ALL INSTRUCTIONS THOROUGHLY! THE WARRANTY WILL BE VOID IF INSTRUCTIONS ARE NOT FOLLOWED EXACTLY. DO NOT WORK UNDER CAR UNDER A VEHICLE SUPPORTED BY A JACK. ALWAYS SUPPORT THE VEHICLE ON SAFETY STANDS.

Installation

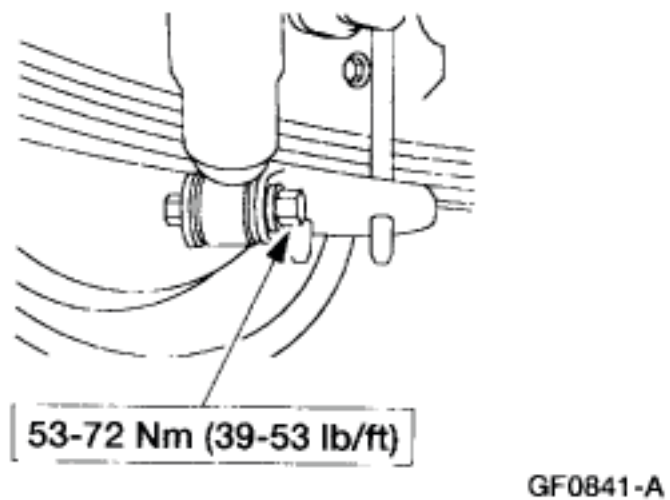
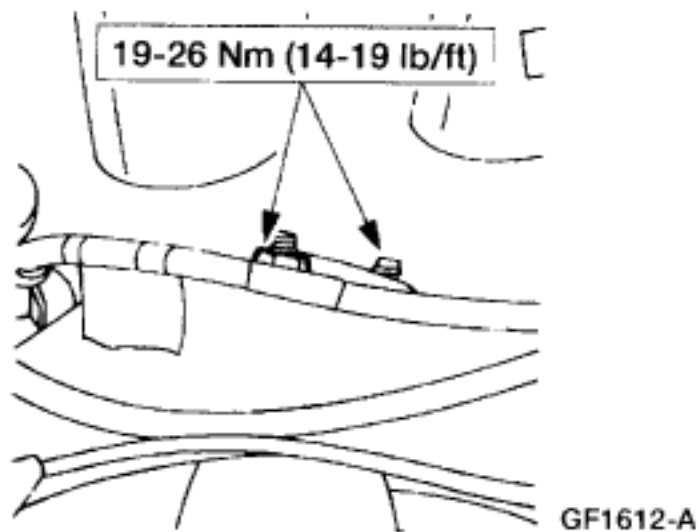

1. **NOTE: When installing air lines make sure the white air line is fully inserted into the fitting for correct installation. To install, reverse the removal procedure.**