

ALL PARTS ARE TO BE INSTALLED BY A CERTIFIED ASE TECHNICIAN



2010-2012 Lexus GX460

2003-2009 Lexus GX 470

2003-2011 Toyota 4Runner

Air Suspension Air to Coil Spring
Conversion Kit with Gas Shocks Rear

63T-30-KIT



Before you begin the removal or installation, please read all or the instructions thoroughly!
The warranty will be void if instructions are not followed exactly. Do not work under a vehicle supported by a jack.
Always support the vehicle safety standards.



BEFORE YOU BEGIN THE REMOVAL OR INSTALLATION, PLEASE READ ALL OF THE INSTRUCTIONS THOROUGHLY!

THE WARRANTY WILL BE VOID IF INSTRUCTIONS ARE NOT FOLLOWED EXACTLY. DO NOT WORK UNDER A VEHICLE SUPPORTED BY A JACK.

ALWAYS SUPPORT THE VEHICLE ON SAFETY STANDS.

Rear Strut Removal

1. Remove the rear wheels.
2. Support the rear axle housing.
3. Remove the bolt and disconnect the rear shock absorber assembly from the rear axle housing.

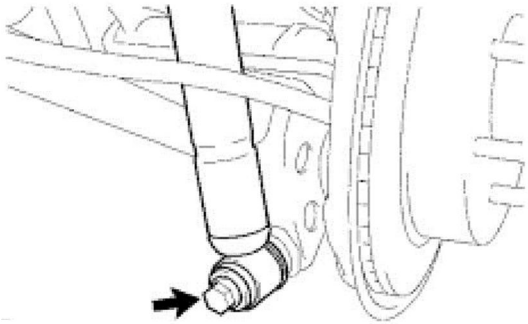

NOTICE:

Do not lower the rear axle housing excessively when disconnecting the rear shock absorber assembly LH with the pneumatic cylinder still installed to the vehicle.

4. Remove the nut, cushion No. 1 and rear shock absorber assembly.

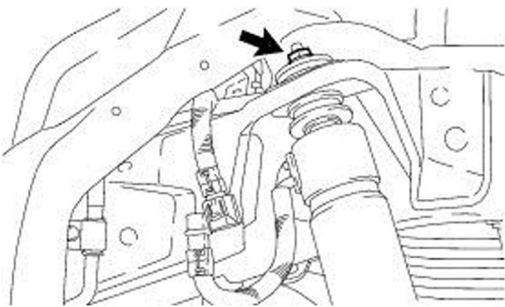

5. Remove the cushion No. 2 from the shock absorber assembly.

Rear Air Spring Removal

6. Disconnect the height control air tube/line.

7. Remove the clip on the top of the air spring.

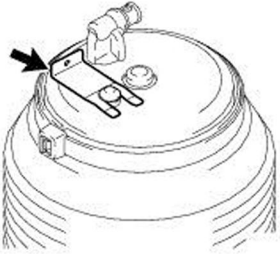

HINT

If the clip cannot be removed easily, pass a wire through the hole and pull it.

8. Place matchmarks on the nut and rear air spring.

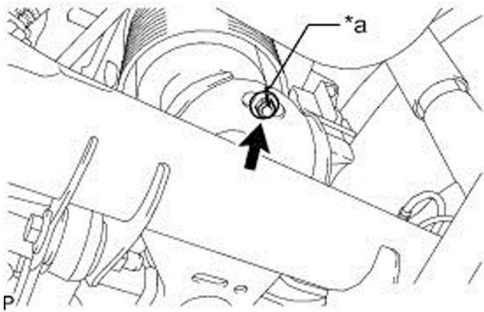

9. Remove the nut.

10. Discharge air from the pneumatic cylinder assembly to cause it to retract.

11. Remove the rear air spring from the rear axle housing.

12. Install conversion kit in reverse order.



BEFORE YOU BEGIN THE REMOVAL OR INSTALLATION, PLEASE READ ALL OF THE INSTRUCTIONS THOROUGHLY!

THE WARRANTY WILL BE VOID IF INSTRUCTIONS ARE NOT FOLLOWED EXACTLY. DO NOT WORK UNDER A VEHICLE SUPPORTED BY A JACK.

ALWAYS SUPPORT THE VEHICLE ON SAFETY STANDS.

Resistors are connected into the wiring at each wheel to bypass the original dampening solenoid. This will allow the Road Sensing Suspension to function without giving the driver a "Suspension Error" message on the instrument cluster. The resistors are only meant to bypass the dampening solenoids, not disable the entire system. Check the suspension codes to ensure that you don't have other problems that will cause a suspension error message. To get an accurate reading of any suspension problems you may have occurring, you will need to clear all suspension codes and then test drive the vehicle and watch for suspension error messages.

Step 1

Cut the wires leading to the dampening solenoid (plug) on the wiring harness leading to the strut/ shock. After cutting the plug off there should be two or four wires.

Step 2

Connect the one wire to each end of the resistor. If you have four wires connect two wires to each end of the resistor. (This is an inline resistor, so it doesn't matter which end of the resistor each wire goes to.)

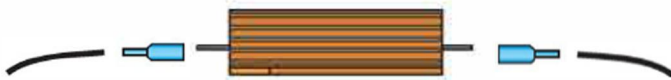

Two wire installation

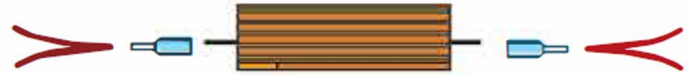

Four wire installation

Step 3

Secure ends of wire to resistor using the connectors provided to prevent shorts and corrosion. To ensure connectors are secure use crimping tool. Tape or heat shrink wrap may be used as well.

******Resistors get very hot and must be installed and tied back onto frame of the vehicle. This will give resistors the proper ventilation and will prevent any issues.******

Step 4

Tie the resistor back out of the way. Installation is now complete.