

ALL PARTS ARE TO BE INSTALLED BY A CERTIFIED ASE TECHNICIAN



2000-2006 BMW X5
Rear Air Spring Assembly

250BW-15-RL
250BW-15-RR

Installation Guide



BEFORE YOU BEGIN THE REMOVAL OR INSTALLATION, PLEASE READ ALL OF THE INSTRUCTIONS THOROUGHLY!

THE WARRANTY WILL BE VOID IF INSTRUCTIONS ARE NOT FOLLOWED EXACTLY. DO NOT WORK UNDER A VEHICLE SUPPORTED BY A JACK.

ALWAYS SUPPORT THE VEHICLE ON SAFETY STANDS.



BEFORE YOU BEGIN THE REMOVAL OR INSTALLATION, PLEASE READ ALL OF THE INSTRUCTIONS THOROUGHLY!

THE WARRANTY WILL BE VOID IF INSTRUCTIONS ARE NOT FOLLOWED EXACTLY. DO NOT WORK UNDER A VEHICLE SUPPORTED BY A JACK.

ALWAYS SUPPORT THE VEHICLE ON SAFETY STANDS.

Removing and installing/replacing rear left or right air spring

Caution:

Applicable to 1-axle air spring only:

Disconnect fuse on air supply system so that there is no unintentional system regulation.

In area of line connections, extreme cleanliness must be ensured during removal and installation.

Even small dirt particles can cause leakage in the system.

Applicable to 2-axle air spring only:

Caution:

The system must be fully depressurized before any components are replaced.

Drive car onto lifting platform and raise car. Lower front and rear axles with BMW diagnostic system in EHC2 program under menu item "Component activation". Carry out each activation 6 times.

After the repairs have been completed, the pneumatic suspension system of the car on the lifting platform must be refilled with air with the diagnostic program (Component activation, raise front and rear axles).

Carry out each activation 6 times.

After this basic filling, lower car from lifting platform, then adjust ride levels in accordance with TIS with diagnostic program and carry out ride level offset.

In area of line connections, extreme cleanliness must be ensured during all tasks!

Even the smallest of dirt particles can cause leakage in the system.

Execute all screw connections in plastic threads with care as threads can very easily be damaged.

Do not kink pipes!

The car must not be set on its wheels with pressureless air spring struts.

The air spring struts can be damaged and destroyed during driving!

A vehicle with a faulty air spring strut is no longer roadworthy!

Remove wheel.

Remove luggage compartment floor panel.

Applicable to 1-axle air spring only:

Note:

Left and right air springs differ.

Left air spring = red identification mark

Right air spring = blue identification mark



Release corresponding line on distributor block (blue = right side, red = left side) and retighten to tightening torque after pressure has reduced; if necessary, release distributor block beforehand.

Applicable to 2-axle air spring only:

Remove connector together with pipe coupling, open pipe coupling by hand.

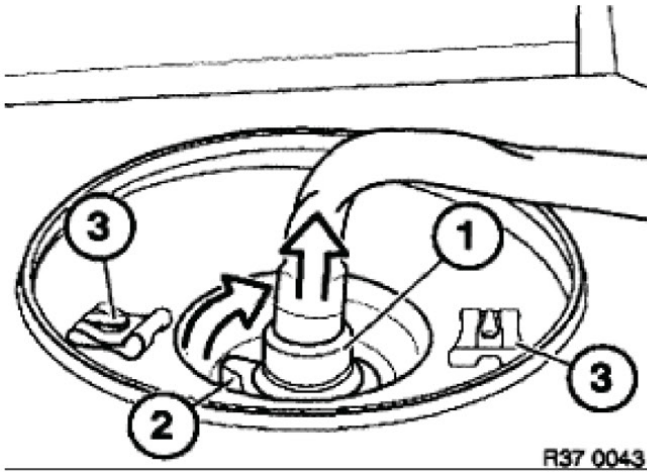

Press quick coupling (1) downwards, keep snap ring (2) pressed and detach quick coupling upwards. Attach protective cap to connection. Remove clips (3).

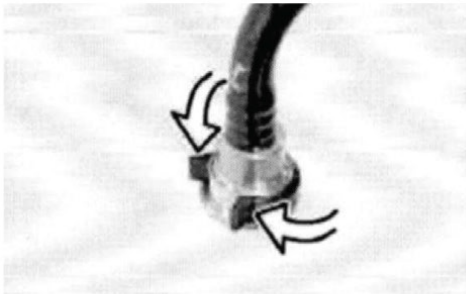

Plug-in coupling with snap ring.

Note:

Compress snap ring in direction of arrows only.

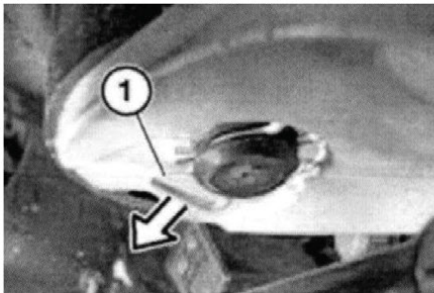

Support wheel carrier with workshop hoist.

Release locking clip (1) on swinging arm and remove air spring towards bottom.



BEFORE YOU BEGIN THE REMOVAL OR INSTALLATION, PLEASE READ ALL OF THE INSTRUCTIONS THOROUGHLY!

THE WARRANTY WILL BE VOID IF INSTRUCTIONS ARE NOT FOLLOWED EXACTLY. DO NOT WORK UNDER A VEHICLE SUPPORTED BY A JACK.

ALWAYS SUPPORT THE VEHICLE ON SAFETY STANDS.

Caution:

Check roll fold of pneumatic spring.

Only install pneumatic spring with a correctly formed roll fold.

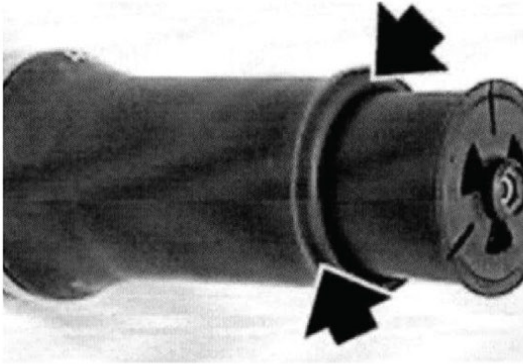

The roll fold is formed when the pneumatic spring is compressed.

Seal off air connection with protective cap. This enables counter-pressure to build up in air spring while pressing together and roll fold forms more easily.

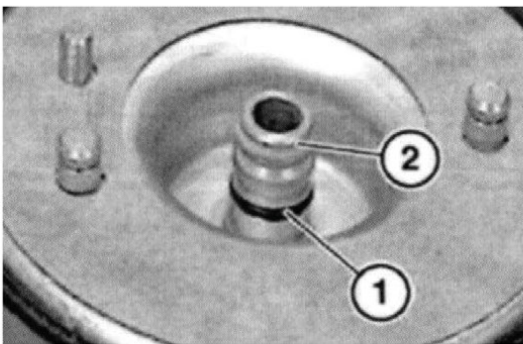

Check correct seating of sealing rings (1 - 2).

Note:

Do not under any circumstances grease sealing rings.

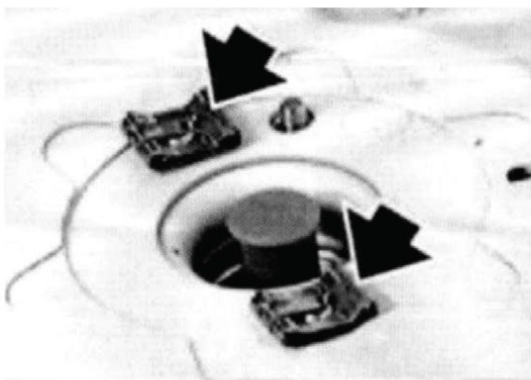

Install pneumatic spring in support with protective cap and attach clip.



BEFORE YOU BEGIN THE REMOVAL OR INSTALLATION, PLEASE READ ALL OF THE INSTRUCTIONS THOROUGHLY!

THE WARRANTY WILL BE VOID IF INSTRUCTIONS ARE NOT FOLLOWED EXACTLY. DO NOT WORK UNDER A VEHICLE SUPPORTED BY A JACK.

ALWAYS SUPPORT THE VEHICLE ON SAFETY STANDS.

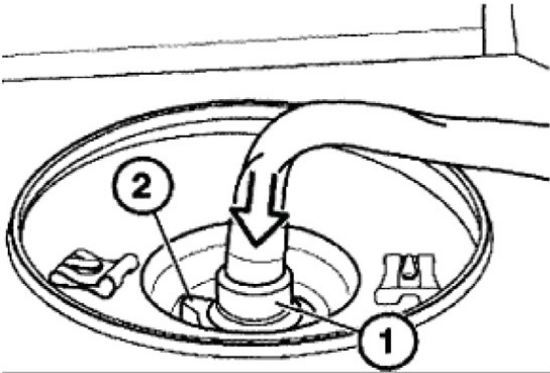

Pull off protective cap.

Attach plug-in coupling (1), ensuring that snap ring (2) snaps audibly into place.

NOTE: If the air line does not go all the way in and does not snap in place, a small modification might be needed:

Sometimes there is too much metal on the top of the Air Line Fitting (2) Not allowing the airline to snap all the way down in place. If this occurs Please remove O-Rings and file down about 1mm on the top of the Air Line Fitting (2) then replace the O-Rings and try to snap the airline again it should fall in place.

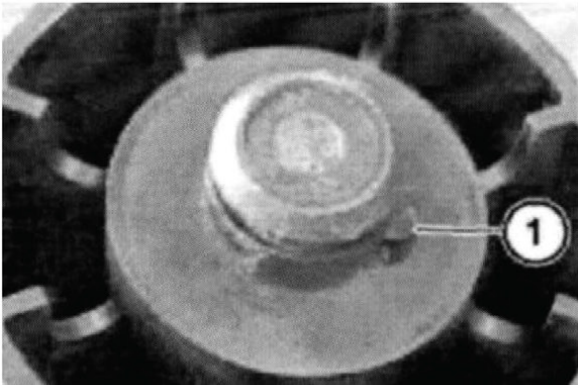
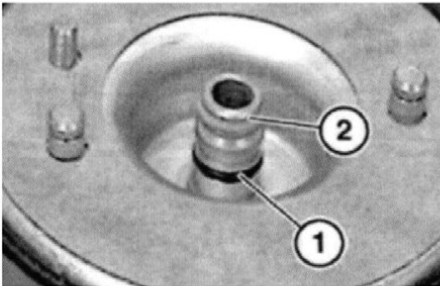

Insert air spring in swinging arm.

Lug (1) must be positioned in opening of swinging arm!

Secure air spring with locking clip