

ALL PARTS ARE TO BE INSTALLED BY A CERTIFIED ASE TECHNICIAN



2011-2014 Jeep Grand Cherokee

Quadra Lift Suspension Air Springs Front

177C-15-F

Installation Guide



BEFORE YOU BEGIN THE REMOVAL OR INSTALLATION, PLEASE READ ALL OF THE INSTRUCTIONS THOROUGHLY!

THE WARRANTY WILL BE VOID IF INSTRUCTIONS ARE NOT FOLLOWED EXACTLY. DO NOT WORK UNDER A VEHICLE SUPPORTED BY A JACK.

ALWAYS SUPPORT THE VEHICLE ON SAFETY STANDS.

8. Separate the outer tie rod end (#3) from the knuckle (#2) with ball joint remover (#1).

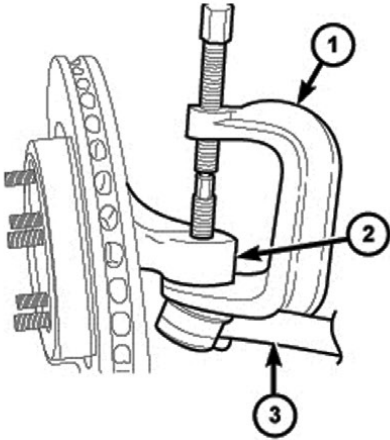

9. Remove the upper ball joint nuts and separate the upper ball joint (#2) from the knuckle (#3) using ball joint press.

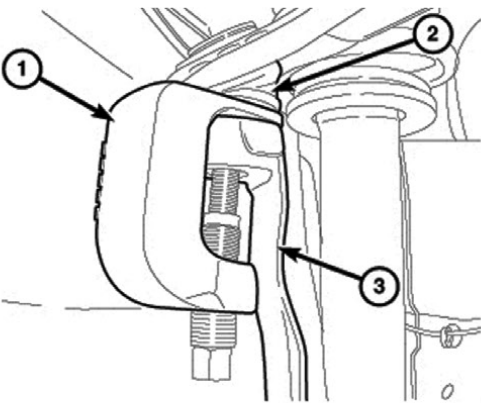

10. Remove shock clevis bolt and nut from lower control arm.

11. Lean the knuckle (#2) out and push half shaft (#1) out of the hub/bearing.

12. Pry half shaft from axle/axle tube with pry bar. There are notches present on the inner C/V joint housing to pry against.

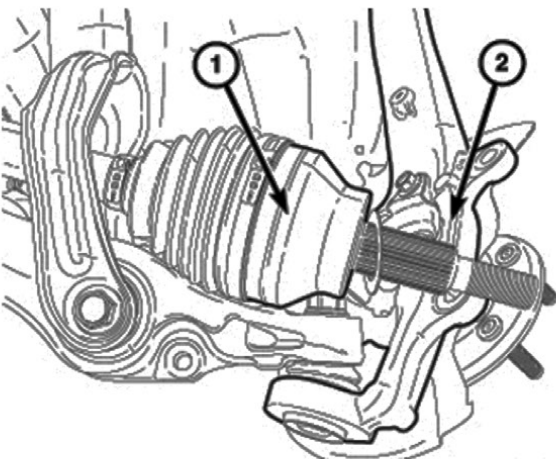

CAUTION:

When removing an air line from a component and the air line is to be reused, do not remove the 90° fitting or the brass fitting from the air line. If either is removed, the air line must be replaced. New components have air line fittings attached; however if the original air line is used the original fitting must also be used. Do not remove protective caps or plugs from air lines or components until ready to install the air line to prevent moisture or dirt intrusion. All air line fittings must be hand started to avoid cross threading.

1. Raise and support the vehicle.

NOTE:

There is not enough clearance to remove the air suspension spring and shock assembly without complete removal of the half shaft.

2. Remove wheel and tire assembly.
3. Remove half shaft hub/bearing nut (#2).

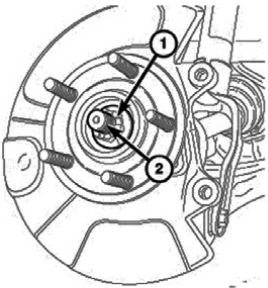

4. Remove wheel speed sensor.
5. Remove brake caliper and allow to hang to the side.
6. Remove tie rod end nut (#1).
7. Remove stabilizer bar link bolts (#5, #7) from lower control arms.

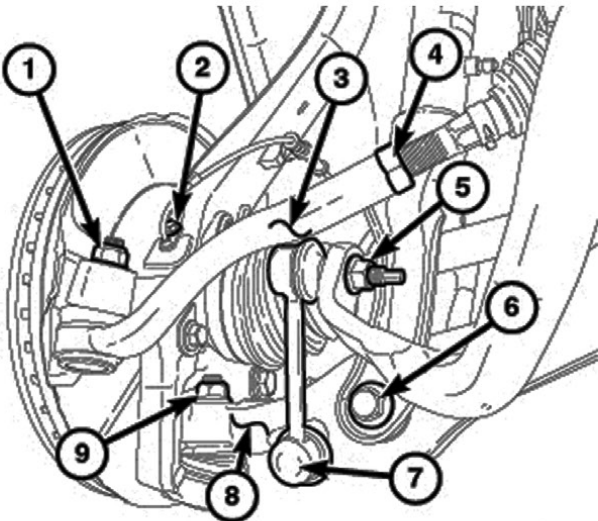



BEFORE YOU BEGIN THE REMOVAL OR INSTALLATION, PLEASE READ ALL OF THE INSTRUCTIONS THOROUGHLY!

THE WARRANTY WILL BE VOID IF INSTRUCTIONS ARE NOT FOLLOWED EXACTLY. DO NOT WORK UNDER A VEHICLE SUPPORTED BY A JACK.

ALWAYS SUPPORT THE VEHICLE ON SAFETY STANDS.

13. Disconnect the air line fitting (#1) from the air suspension spring and shock assembly.

NOTE:

Do not remove the fitting from the air line. During installation the same fitting will be used.

Only remove the air line fitting (hex portion) and not the Pressure Retention Valve (round portion) of the brass assembly on top of the air suspension spring and shock assembly. Removing and reinstalling the valve (round) part of the assembly may cause a leak.

14. Remove the upper mounting nuts (#2).

15. Turn the wheels so the front of the tire on the side being serviced is turned to the inside of the vehicle.

16. Remove the air suspension assembly.

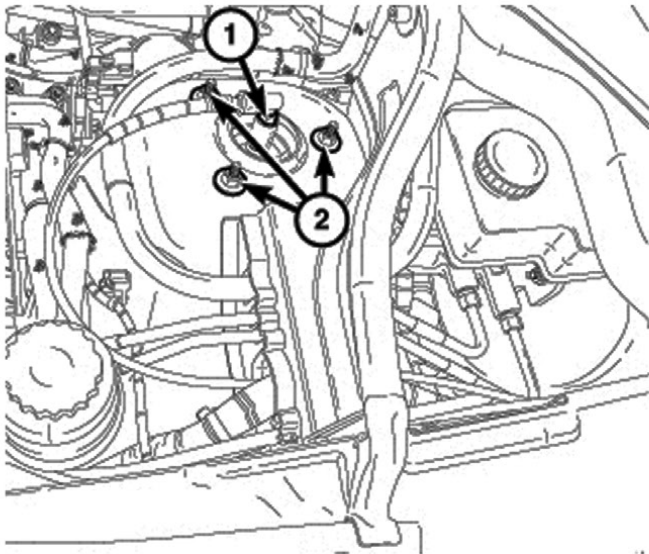

17. Remove retention nut on the top of the strut.

18. Slide the air spring assembly off of the shock.

19. Replace o-rings on the bottom of the shock and on the top of the air spring assembly.

20. Install top retention nut.

21. Install completed strut in reverse order.

ALL PARTS ARE TO BE INSTALLED BY A CERTIFIED ASE TECHNICIAN

Learn more about suspension parts on our website.