

ALL PARTS ARE TO BE INSTALLED BY A CERTIFIED ASE TECHNICIAN



2004-2009 Cadillac SRX

Active Suspension Air Shock

155G-13-R

Installation Instructions



Before you begin the removal or installation, please read all or the instructions thoroughly!
The warranty will be void if instructions are not followed exactly. Do not work under a vehicle supported by a jack.
Always support the vehicle safety standards.

1. Fold Down Rear Seats.

2. Remove Rear Quarter Trim Tie Down Bezel. (1)

3. Remove the Side Door Garnish Molding by Pulling the Panel From Locator Holes. (2)

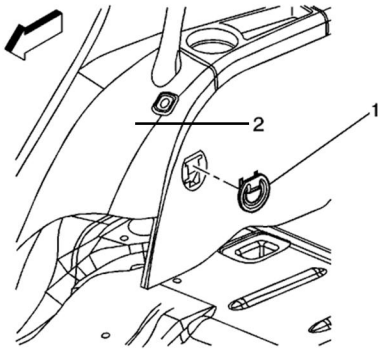

4. Remove Upper "C" Pillar Garnish Molding. (1)

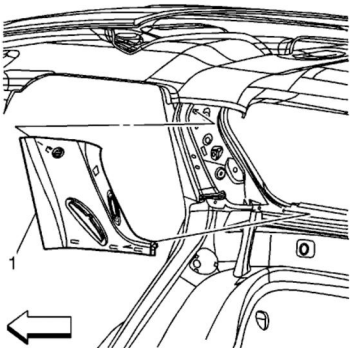

5. Pull the Side Trim Panel Away From the Body. (1)

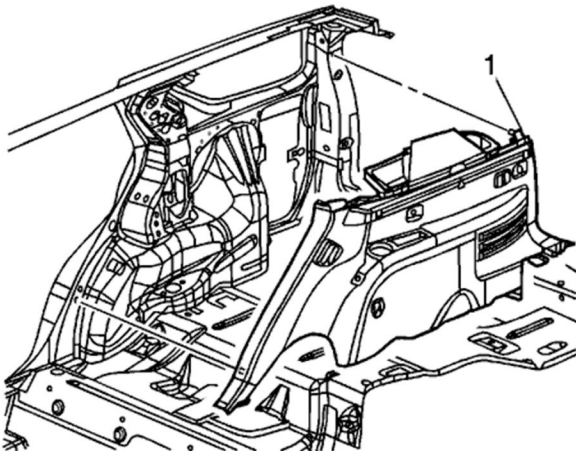



BEFORE YOU BEGIN THE REMOVAL OR INSTALLATION, PLEASE READ ALL OF THE INSTRUCTIONS THOROUGHLY!

THE WARRANTY WILL BE VOID IF INSTRUCTIONS ARE NOT FOLLOWED EXACTLY. DO NOT WORK UNDER A VEHICLE SUPPORTED BY A JACK.

ALWAYS SUPPORT THE VEHICLE ON SAFETY STANDS.

6. Behind the Trim Panel Just Removed, Remove the Sound Insulator Away From Shock Tower.

7. Remove Electrical Connector From Top of Shock. (1)

8. Remove the Upper Shock Mounting Nuts. (2)

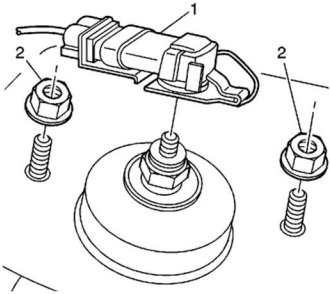

9. Raise and Support the Vehicle.

10. Remove Air Line From Shock.

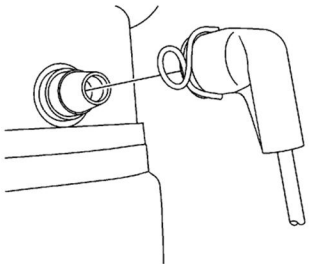

11. Remove the Lower Shock Mounting Bolt. Remove Shock From Vehicle.

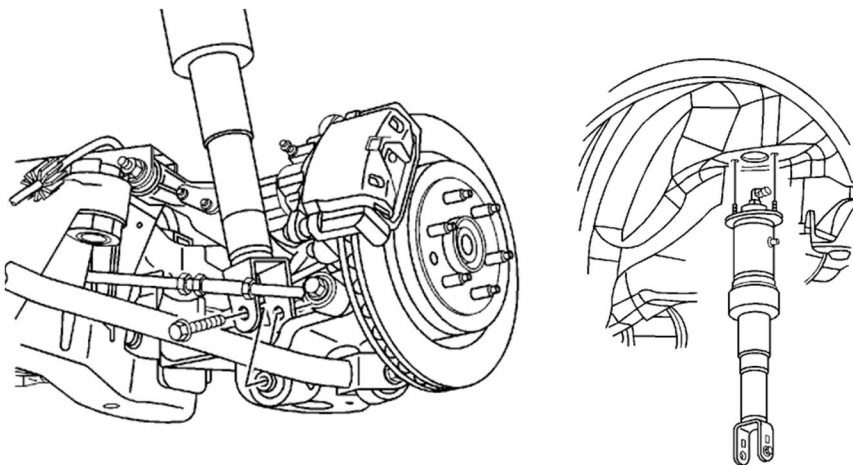

12. Install in Reverse Order.