

ALL PARTS ARE TO BE INSTALLED BY A CERTIFIED ASE TECHNICIAN



- 2002-2006 Cadillac Escalade**
- 2003-2006 Cadillac Escalade ESV**
- 2002-2006 Cadillac Escalade EXT**
- 2002-2006 Chevrolet Avalanche 1500**
- 2003-2006 Chevrolet Silverado 1500**
- 2000-2006 Chevrolet Suburban**
- 2000-2006 Chevrolet Tahoe**
- 2000-2006 GMC Yukon**
- 2001-2006 GMC Yukon XL 1500**

Active to Passive Gas Shock Absorber
Conversion Front Pair

150G-12-F



Before you begin the removal or installation, please read all or the instructions thoroughly!
The warranty will be void if instructions are not followed exactly. Do not work under a vehicle supported by a jack.
Always support the vehicle safety standards.

Removal & Installation

1. Raise and support the vehicle.
2. Support the lower control arm with a jack stand.
3. Disconnect the Electronic suspension Control (ESC) link rod from the sensor.

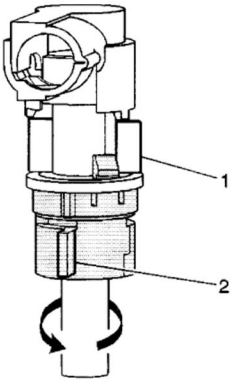

4. Grasp the connector lock tabs (1, 2). Rotate the connector tabs counterclockwise until the connector is unlocked.
5. Disengage the connector from the tension by firmly pulling the connector up.

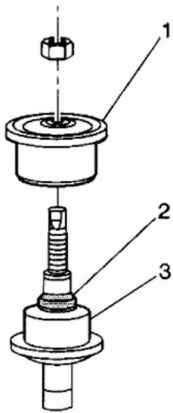

- 6 Hold the tension end with a wrench while removing the nut.
7. Remove the nut.
8. Remove the upper insulator (1). Do not discard the plastic pilot ring (2).

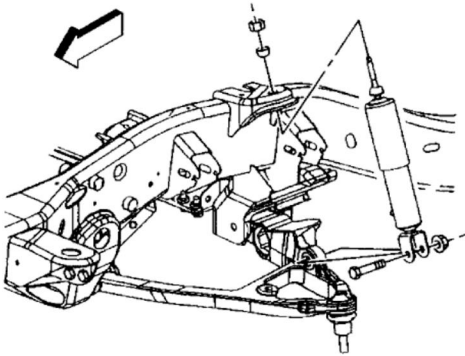

9. Remove the shock absorber mounting bolt at the lower control arm, 15 Series.

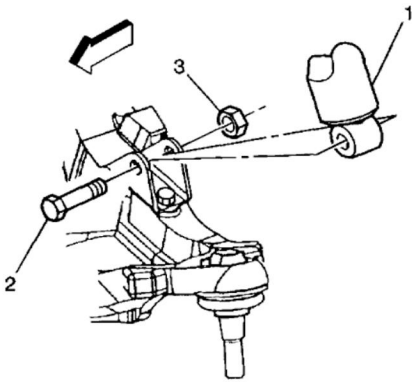

10. Remove the shock absorber mounting bolt (2) at the lower control arm, 25/35 Series.

11. Remove the shock absorber.

12. Install in reverse order.



BEFORE YOU BEGIN THE REMOVAL OR INSTALLATION, PLEASE READ ALL OF THE INSTRUCTIONS THOROUGHLY!

THE WARRANTY WILL BE VOID IF INSTRUCTIONS ARE NOT FOLLOWED EXACTLY. DO NOT WORK UNDER A VEHICLE SUPPORTED BY A JACK.

ALWAYS SUPPORT THE VEHICLE ON SAFETY STANDS.

Resistors are connected into the wiring at each wheel to bypass the original dampening solenoid. This will allow the Road Sensing Suspension to function without giving the driver a "Suspension Error" message on the instrument cluster. The resistors are only meant to bypass the dampening solenoids, not disable the entire system. Check the suspension codes to ensure that you don't have other problems that will cause a suspension error message. To get an accurate reading of any suspension problems you may have occurring, you will need to clear all suspension codes and then test drive the vehicle and watch for suspension error messages.

Step 1

Cut the wires leading to the dampening solenoid (plug) on the wiring harness leading to the strut/ shock. After cutting the plug off there should be two or four wires.

Step 2

Connect the one wire to each end of the resistor. If you have four wires connect two wires to each end of the resistor. (This is an inline resistor, so it doesn't matter which end of the resistor each wire goes to.)

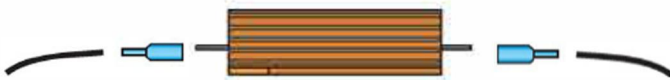

Two wire installation

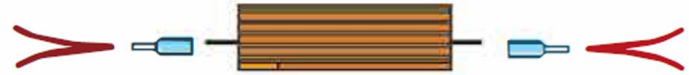

Four wire installation

Step 3

Secure ends of wire to resistor using the connectors provided to prevent shorts and corrosion. To ensure connectors are secure use crimping tool. Tape or heat shrink wrap may be used as well.

******Resistors get very hot and must be installed and tied back onto frame of the vehicle. This will give resistors the proper ventilation and will prevent any issues.******

Step 4

Tie the resistor back out of the way. Installation is now complete.