

ALL PARTS ARE TO BE INSTALLED BY A CERTIFIED ASE TECHNICIAN



**2004-2007 Buick Ranier**  
**2002-2009 Chevrolet Trailblazer**  
**2002-2006 Chevrolet Trailblazer EXT**  
**2002-2009 GMC Envoy**  
**2002-2006 GMC Envoy XL**  
**2002-2005 GMC Envoy XUV**  
**2003-2008 Isuzu Ascender**  
**2002-2004 Oldsmobile Bravada**  
**2005-2009 Saab 9-7x**



Heavy Duty Air Suspension Air Springs Rear  
**148G-15-HD**

## Installation Guide

BEFORE YOU BEGIN THE REMOVAL OR INSTALLATION, PLEASE READ ALL OF THE INSTRUCTIONS THOROUGHLY!

THE WARRANTY WILL BE VOID IF INSTRUCTIONS ARE NOT FOLLOWED EXACTLY. DO NOT WORK UNDER A VEHICLE SUPPORTED BY A JACK.

ALWAYS SUPPORT THE VEHICLE ON SAFETY STANDS.



BEFORE YOU BEGIN THE REMOVAL OR INSTALLATION, PLEASE READ ALL OF THE INSTRUCTIONS THOROUGHLY!

THE WARRANTY WILL BE VOID IF INSTRUCTIONS ARE NOT FOLLOWED EXACTLY. DO NOT WORK UNDER A VEHICLE SUPPORTED BY A JACK.

**ALWAYS SUPPORT THE VEHICLE ON SAFETY STANDS.**

## Air Sprin Replacement

### Removal Procedure

#### 1. Depressurize the air suspension system

**Important:** Remove the air suspension system fuse before working on the rear suspension components or the rear axle. Failure to remove the air suspension system fuse could cause the calibration of the air suspension leveling sensor to change and the air suspension system not to function properly.

#### 2. Remove the air suspension system fuse.

Fuse Block – Underhood (5.3L), Label

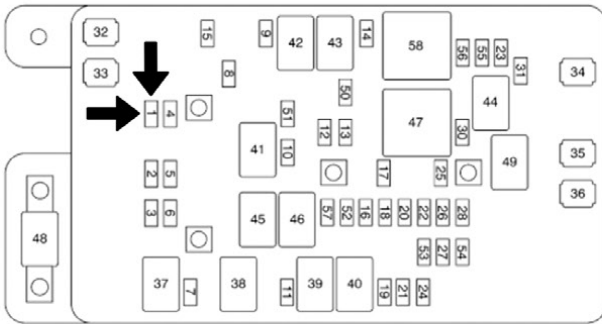

**Important:** There is a raised feature on the outer rim of the air spring top plate that denotes the anti rotation peg position.

#### 3. Depress the anti rotation peg (2) in the air spring top plate located in the upper spring seat.

#### 4. With the anti rotation peg (2) depressed, rotate the air spring counterclockwise and remove the air spring from the upper spring seat.

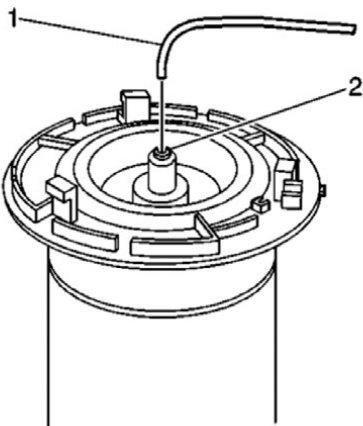



**5. Disconnect the air supply line from the air spring in the following way:**

**Push the air supply line into the air spring connection and hold in place.**

**Depress and hold the air supply line collet (2) down.**

**Remove the air supply line (1) from the air spring.**

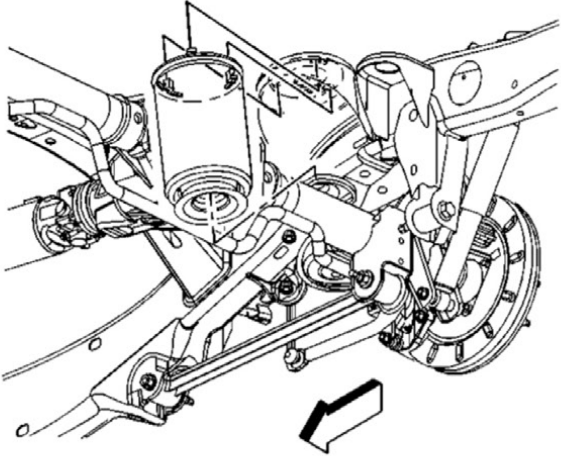

**6. Remove the air spring from the vehicle.**

**Installation Procedure**

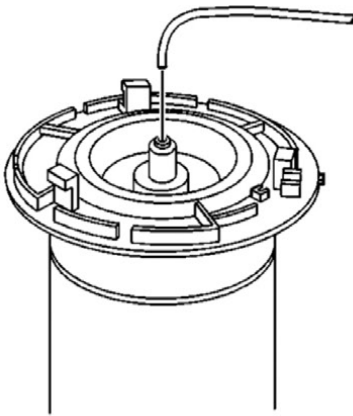

**1. Install the air supply line to the air spring. Ensure the air supply line is fully seated.**

**Caution: Ensure that the air spring is fully seated and properly positioned on the axle pilot. Failure to properly position the air spring may cause the air spring to break apart, possibly resulting in personal injury or damage to the vehicle.**

**2. Install the air spring (2) to the frame by aligning the mounting tabs (3) with the keyhole slots (1) in the upper spring seat.**



BEFORE YOU BEGIN THE REMOVAL OR INSTALLATION, PLEASE READ ALL OF THE INSTRUCTIONS THOROUGHLY!

THE WARRANTY WILL BE VOID IF INSTRUCTIONS ARE NOT FOLLOWED EXACTLY. DO NOT WORK UNDER A VEHICLE SUPPORTED BY A JACK.

**ALWAYS SUPPORT THE VEHICLE ON SAFETY STANDS.**

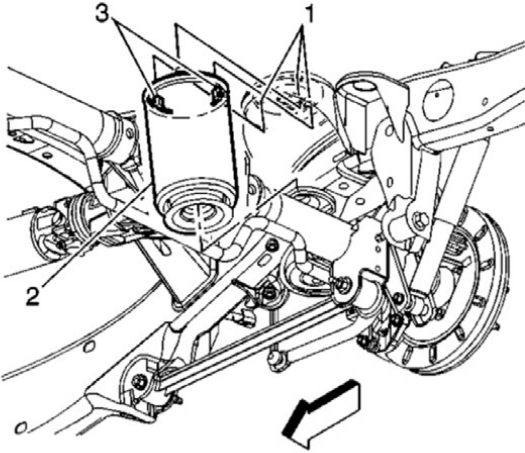

3. Apply upward pressure to the air spring (2) and rotate clockwise until the anti rotation peg snaps into place. **Important: After the air suspension has been depressurized, DO NOT allow the vehicle to be completely lowered onto the rear jounce bumpers.**

**Important: After the air suspension has been depressurized, DO NOT allow the vehicle to be completely lowered onto the rear jounce bumpers.**

4. Lower the vehicle slightly below the correct D-height position.
5. Install the air suspension system fuse.
6. Turn ON the ignition, engine OFF. Allow the air suspension compressor to run for approximately 1 minute to ensure that the air suspension is functioning properly.