

ALL PARTS ARE TO BE INSTALLED BY A CERTIFIED ASE TECHNICIAN



2007-2013 Mercedes-Benz CL550
2012-2013 Mercedes-Benz S350
2010-2013 Mercedes-Benz S400
2008-2011 Mercedes-Benz S450
2007-2011 Mercedes-Benz S500
2007-2013 Mercedes-Benz S550

Airmatic and 4-Matic Suspension
Electronic Air Strut Rear Left

136M-28-RL RR

Installation Instructions



Before you begin the removal or installation, please read all or the instructions thoroughly!
The warranty will be void if instructions are not followed exactly. Do not work under a vehicle supported by a jack.
Always support the vehicle safety standards.



BEFORE YOU BEGIN THE REMOVAL OR INSTALLATION, PLEASE READ ALL OF THE INSTRUCTIONS THOROUGHLY!

THE WARRANTY WILL BE VOID IF INSTRUCTIONS ARE NOT FOLLOWED EXACTLY. DO NOT WORK UNDER A VEHICLE SUPPORTED BY A JACK.

ALWAYS SUPPORT THE VEHICLE ON SAFETY STANDS.

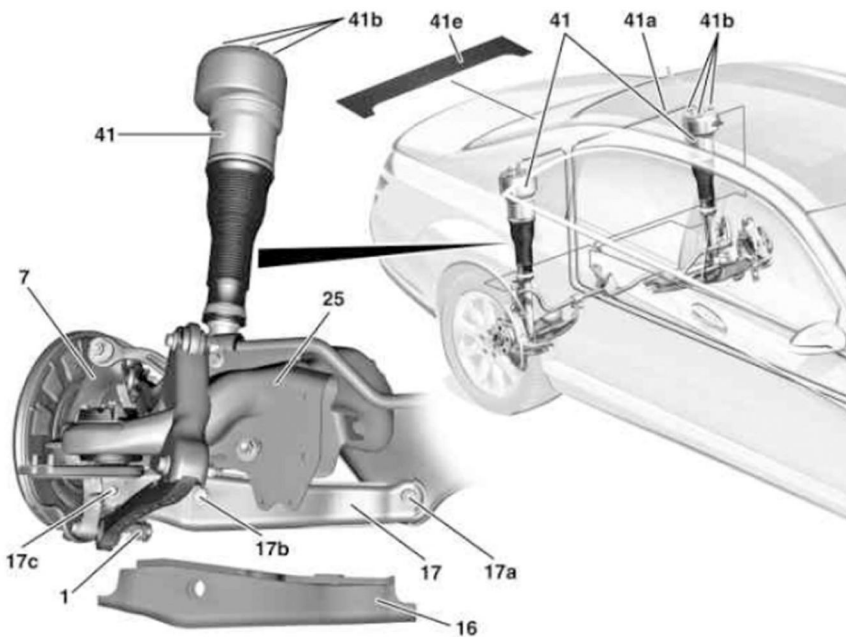

- 1 - Stabilizer bar link rod**
- 7 - Wheel carrier**
- 16 - Cover**
- 17 - Spring control arm**
- 17a - Screw**
- 17b - Screw**
- 17c - Screw**
- 25 - Rear axle carrier**
- 41 - Suspension strut**
- 41a - Pressure line**
- 41b - Nut**
- 41e - Speaker cover**

Rear Strut Removal & Installation

- 1. Unclip speaker cover (41e) from rear shelf and remove.**
- 2. Remove paneling from C-pillar.**
- 3. Push the foam interlayer to one side until the pressure line (41a) and nuts (41b) of the suspension strut (41) are freely accessible.**
- 4. Detach pressure line (41a) from suspension strut (41) and place aside.**
- 5. Unscrew nuts (41b) from suspension strut (41).**
- 6. Lift vehicle on stable platform.**
- 7. Remove rear wheel.**
- 8. Remove inner fender lining from fender.**
- 9. Disconnect electrical connector in wheel well.**

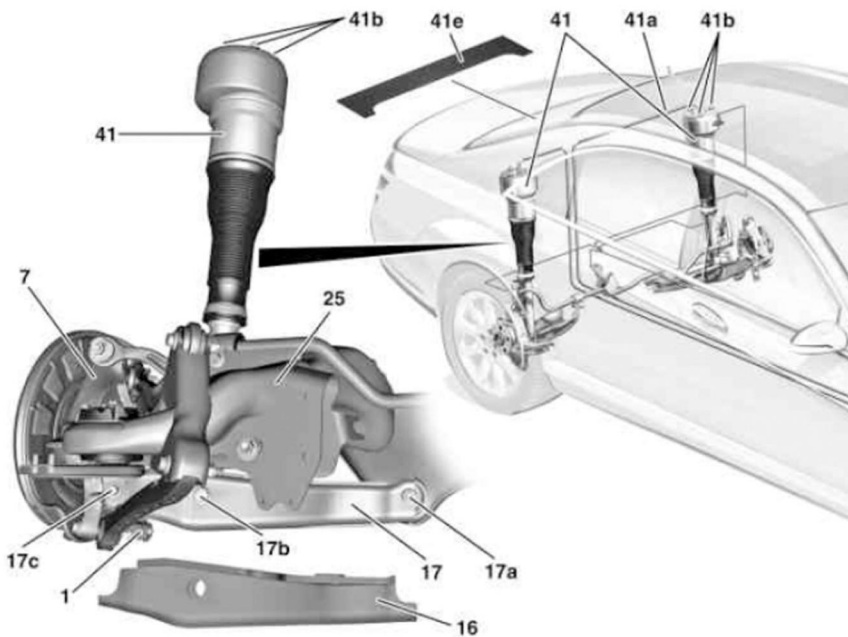

- 1 - Stabilizer bar link rod**
- 7 - Wheel carrier**
- 16 - Cover**
- 17 - Spring control arm**
- 17a - Screw**
- 17b - Screw**
- 17c - Screw**
- 25 - Rear axle carrier**
- 41 - Suspension strut**
- 41a - Pressure line**
- 41b - Nut**
- 41e - Speaker cover**

10. Detach paneling (16) from spring control arm (17).

11. Remove spring control arm (17).

12. Loosen bolt (17c) securing spring control arm (17) to wheel carrier (7).

13. Detach bolt (17b) securing suspension strut (41) to spring control arm (17).

14. Remove bolt (17a) securing spring control arm (17) to rear axle carrier (25).

15. Swing spring control arm (17) downward.

16. Remove suspension strut (41).

17. Install in reverse order.