

ALL PARTS ARE TO BE INSTALLED BY A CERTIFIED ASE TECHNICIAN



2007-2011 Mercedes-Benz CLS 550

2003-2009 Mercedes-Benz E320

2003-2006 Mercedes-Benz E500

2003-2006 Mercedes Benz E55 AMG

2007-2009 Mercedes-Benz E550

2007-2009 Mercedes-Benz E63 AMG

Rear Airmatic Air to Coil Spring Suspension
Conversion Kit

127M-30-R





BEFORE YOU BEGIN THE REMOVAL OR INSTALLATION, PLEASE READ ALL OF THE INSTRUCTIONS THOROUGHLY!

THE WARRANTY WILL BE VOID IF INSTRUCTIONS ARE NOT FOLLOWED EXACTLY. DO NOT WORK UNDER A VEHICLE SUPPORTED BY A JACK.

ALWAYS SUPPORT THE VEHICLE ON SAFETY STANDS.

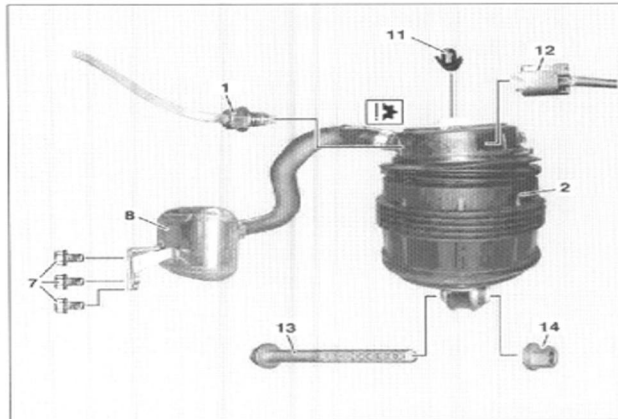

- 1 Pressure line
- 2 Air spring
- 7 Bolts
- 8 Additional volume reservoir
- 11 Retainer clip
- 12 Electrical connectors
- 13 Screw
- 14 Nut

CAUTION:

● The air spring may only be removed together with the additional volume reservoir. The connecting hose from the air spring to the additional volume reservoir must not be disconnected otherwise leakage will occur. Furthermore, it should be ensured that before removal the air springs are emptied completely using STAR DIAGNOSIS.

1. Disconnect pressure line (1) from air spring (2).
2. Disconnect the electrical connector (12) from the rear axle level sensor (B22/3) and detach the rear axle level sensor (B22/3) from the rear axle carrier (6).
3. Detach torsion bar (5) from rear axle carrier (6).
4. Unscrew bolts (7) of additional volume reservoir (8) from front center assembly mounting (9).
5. Detach air spring (2) from spring link (10) and remove air spring (2) together with additional volume reservoir (8).

Installation

1. Reusing the air spring bag bottom installation bolt, bolt the bottom coil bracket in place.
2. Install top mount into coil.
3. Compress the Coil to allow for easy installation.
4. Install Coils Top First into position.