

WARNING: CAREFULLY READ THE FOLLOWING INSTALLATION INFORMATION

5000 lb **ELECTRIC A-FRAME JACK**

SPECIFICATIONS:

- Models Applicable: 5000 lb Electric A-Frame Jack
- Maximum Lift Capacity: 5000 lbs (continuous use)
- Retracted Height: 31 3/8"
- Vertical Travel: 18"
- Power Requirements: 12V DC
- Outer Tube Diameter: 2 1/4"
- Power Cord Length: 5.57ft, #10 Gauge Wire
- Foot Pad Diameter: 5 1/2"
- LED Work Lights For Easy Nighttime Hookups
- Shipping Weight: 25 lbs

CONTENTS OF KIT:

- Removable Foot Pad
- 3/8" Safety Lock Pin
- Manual Crank Handle
- 25 A Spare Fuse
- Three 3/8" Star Washers

TOOLS REQUIRED:

- 9/16" Wrench
- Torque Wrench
- Wire Cutters
- Wire Strippers
- Crimpers OR Soldering Iron

NOTICE:

IF PRODUCT COMPONENTS ARE MISSING OR DAMAGED, DO NOT RETURN TO DEALER. CONTACT THE MANUFACTURER.

Installation Instructions

WARNING: KEEP HANDS, FEET, AND BODY OUT FROM BENEATH THE JACK & TRAILER TO AVOID THE RISK OF HARM OR FATAL INJURY!

BEFORE INSTALLATION, COMPARE THE LIFT CAPACITY OF THE STROMBERG CARLSON TONGUE JACK WITH YOUR TRAILER TO ENSURE SAFE OPERATION OF THE JACK.

1. Park the trailer on a level surface and block the wheels.
2. Support the trailer tongue by the frame with jack stands.
3. If replacing an old jack, remove the old jack from the coupler, saving the washers and bolts.
4. Insert the electric jack into the jack hole, aligning the bolt holes so the motor housing is facing forward as shown in Fig 1.
5. Secure the jack with three (3) grade 5, 3/8"-16 UNC bolts and washers. Place the star washers between the flat washers and mounting plate as shown in Fig 1. The star washers are intended to penetrate through the paint on the mounting plate to ensure direct metal to metal contact. Bolts should be tightened to 15-20 ft-lb.
Tip: The salvaged bolts from the old jack are acceptable for reuse if they are grade 5 and in good condition.
6. If a lower support plate is not already present, install one in the bottom of the trailer frame. Do not operate the jack without a lower support plate.
7. Install the fuse holder as close as possible to the positive terminal of the power source by either crimping or soldering the connections.
8. Connect the jack lead (black) to the fuse holder. Since the jack is internally grounded, a ground wire is not necessary. Alternatively, wire the jack lead directly to the reset breaker if available. The reset breaker may be located at the corner of the first cross member of the A frame.

Operation Instructions

1. Park your trailer on a level surface and block all dolly and trailer wheels.
Tip: For night time hookups, flip the light switch ON to illuminate your work area.
2. Before operating the jack, attach the foot with the 3/8" safety lock pin provided.

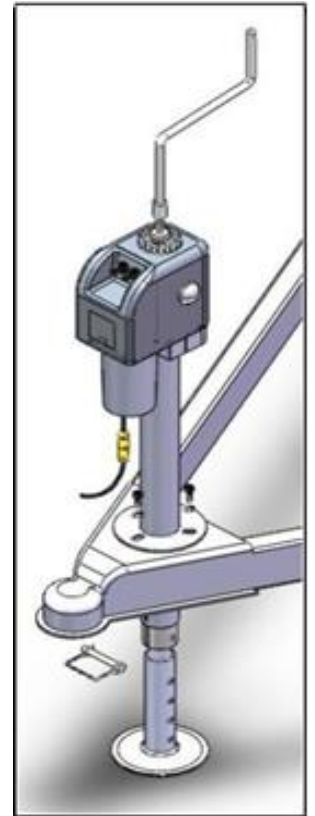

Fig 1

Warning: DO NOT stack blocks under the jack's foot to increase the height. Stacked blocks may become unstable and fall.

3. Extend the jack by pushing the operating switch UP.
Note: Under heavy use, the circuit breaker may open, causing the motor to switch off. In this case, release the operating switch and wait 15 seconds for the breaker to reset before resuming operation. Retract the jack by pushing the operating switch down.
Note: The jack will slow down and stop as it approaches the fully retracted position. Release the switch at first sign of slowing.
4. Before driving, remove the foot or position it in the highest position and completely retract the jack.

Manual Operation Instructions

1. Disconnect the jack from the power source.
2. Remove the rubber access covers on the top of the jack and on the side of the motor cover.
3. Insert the manual crank handle into the access hole on the top of the jack, engaging the drive screw.
4. Rotate the manual crank handle counter-clockwise to extend the jack, and clockwise to retract it.

Replacement Parts

REF	DESCRIPTION
AF	Upper Jack Assembly; includes all housing, gear motor box assembly & items A-F
A1	Operating switch, (1) Extend/Retract
A2	Operating switch, (1) Light -on/off
B	Switch boot (2pack)
C	LED light
D	Circuit breaker
E	Cap with Bubble level
F	Motor
G-H	Lower Jack Assembly; includes outer jack tube, Inner jack tube, screw shaft & items G-H
G	Removable foot pad
H	3/8" safety lock pin
I	Manual crank handle
J	Star washer (3 pieces)
K	Power lead with fuse holder (25 amp fuse)
M	Limited Gear Box

Maintenance

To keep your jack in good, functional condition, fully extend the jack and clean the inner jack tube once a year. After cleaning, coat the tube with a light grease or silicone spray lubricant.

Troubleshooting-Problem: motor isn't operating.

CAUSE	SOLUTION
Open Circuit Breaker	Wait 15 seconds for the breaker to close.
Poor Ground	Clean area between the jack mounting plate and coupler, and ensure paint has been removed by the star washers. Direct metal-to-metal contact must exist between mounting components to ensure good electrical contact.
No or Low Voltage	Check battery & electrical connections. Power supplied must be at least 10V DC. If the battery is low, plug the trailer cable into the tow vehicle, and start the tow vehicle to provide power to the jack.
Blown Fuse	Replace fuse with a new 25A fuse.

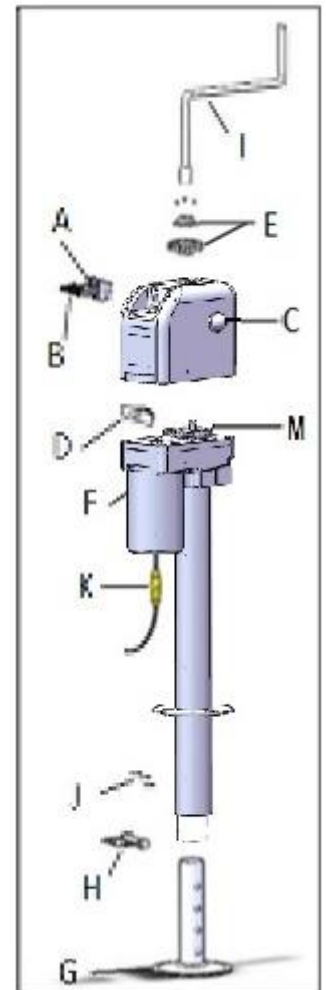

Fig 2